

Installation & Operations Manual

WS/WD MODELS WATER-TO-WATER HEAT PUMPS

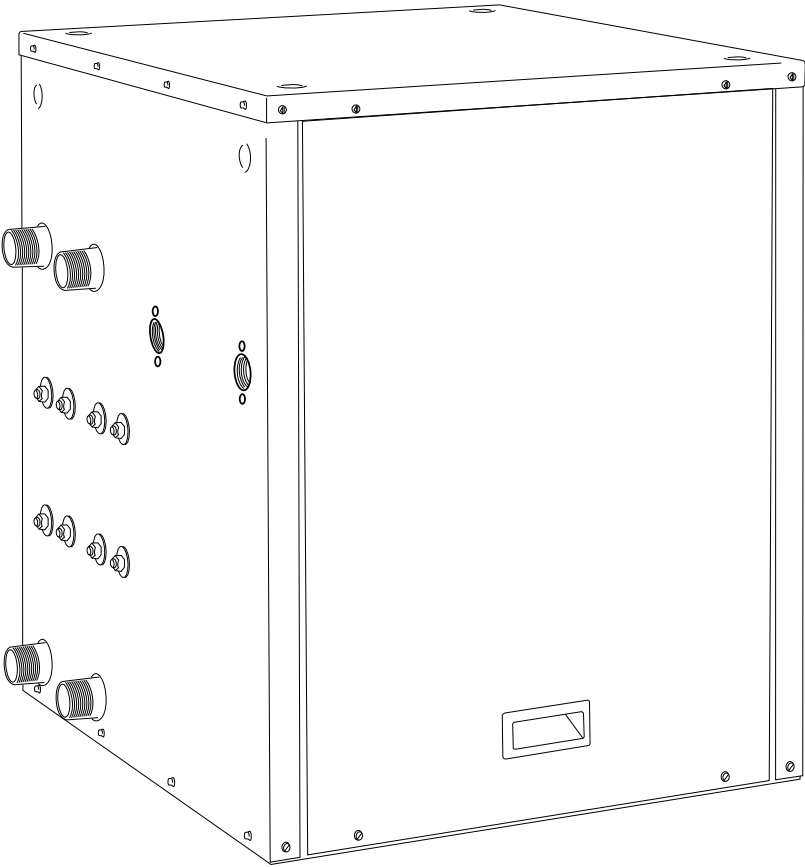

20D817-01NN

Table of Contents

Section 1: Model Nomenclature and AHRI Performance Data

| | |
|---------------------------------------|---|
| Unit Model Nomenclature Decoder | 4 |
|---------------------------------------|---|

Section 2: Installation Introduction

| | |
|------------------------|---|
| Inspection..... | 5 |
| Unit Protection | 5 |
| Pre-Installation | 5 |

Section 2: Installation Introduction

| | |
|------------------------------|---|
| Pre-Installation Steps | 6 |
| Components | 6 |

Section 3: Installation Considerations

| | |
|---|---|
| Consumer Instructions | 7 |
| Enertech Global D-I-Y Policy..... | 7 |
| Unit Placement | 7 |
| Pre-Installation | 8 |
| Buffer Tanks..... | 8 |
| Guidelines For Heating Mode Operation | 9 |

Section 4: Unit Data Information

| | |
|-----------------------------|----|
| Unit Dimensional Data | 10 |
| Unit Electrical Data..... | 11 |

Section 5: Unit Piping Installation

| | |
|---|----|
| Water Quality | 12 |
| Interior Piping..... | 13 |
| Typical Pressurized Flow Center Installation | 14 |
| Typical Non-Pressurized Flow Center Installation..... | 14 |
| WD Models..... | 14 |
| WS Models | 14 |
| Pressurized Flow Center and Pump Mounting | 15 |
| Open Loop Piping..... | 16 |
| Typical Storage Tank Piping For Radiant Floor Heating | 17 |

Section 6: Antifreeze

| | |
|-------------------------------------|----|
| Condensation Drain Connection | 18 |
| Antifreeze Overview..... | 18 |
| Antifreeze Charging..... | 19 |
| Antifreeze Specific Gravity | 20 |

Section 7: Desuperheater Installation

| | |
|---|----|
| Desuperheater Installation | 21 |
| Plumbing Installation..... | 21 |
| Typical Desuperheater Installation | 22 |
| Desuperheater Installation with Preheat Tank..... | 23 |

Section 8: Controls

| | |
|-----------------------------|-------|
| Features and Controls | 24-29 |
|-----------------------------|-------|

Section 9: Wiring Diagrams

| | |
|-----------------------|-------|
| Wiring Diagrams | 30-42 |
|-----------------------|-------|

Section 10: Equipment Start-Up Procedures

Equipment Start-up Form 43
Equipment Start-up Process 44
Operating Parameters 45
Pressure Drop Tables 46
Performance Check 47
Specification Glossary, Calculations..... 48
Source Water Flow Selection 48
Application Notes for Performance Data 48
Application Notes for Performance Data 49-50

Section 11: Troubleshooting

Refrigeration Troubleshooting 51
Superheat/Subcooling Conditions..... 51
Typical R-410A Unit Superheat/Subcooling Values..... 51

Section 12: Warranty Forms and Revision Table

Order and Claim..... 52
Registration 53
Revision Table 54

Section 1: Model Nomenclature and AHRI Performance Data

Unit Model Nomenclature Decoder

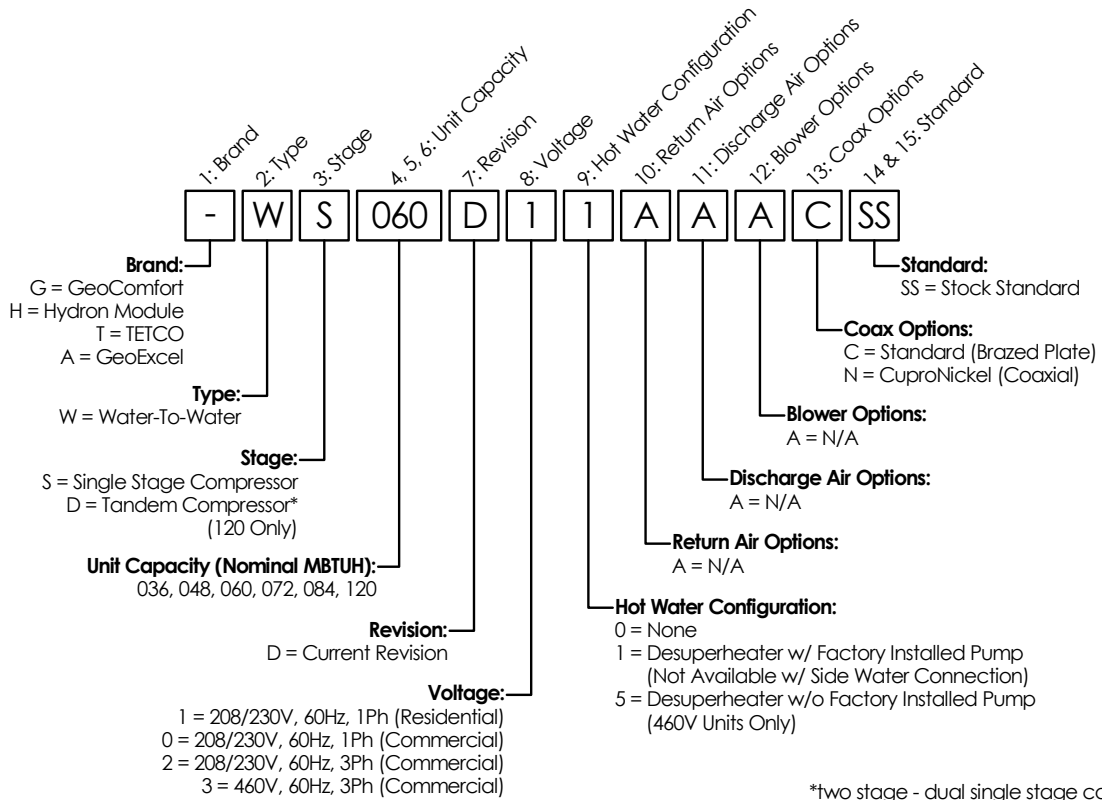

Section 2: Installation Introduction

Introduction

This geothermal heat pump provides heated water and chilled water as well as optional domestic water heating capability. Engineering and quality control is built into every geothermal unit. Good performance depends on proper application and correct installation.

Notices, Cautions, Warnings, & Dangers:

“NOTICE” Notification of installation, operation or maintenance information which is important, but which is NOT hazard-related.

“CAUTION” Indicates a potentially hazardous situation or an unsafe practice which, if not avoided, COULD result in minor or moderate injury or product or property damage.

“WARNING” Indicates potentially hazardous situation which, if not avoided, COULD result in death or serious injury.

“DANGER” Indicates an immediate hazardous situation which, if not avoided, WILL result in death or serious injury.

Inspection

Upon receipt of any geothermal equipment, carefully check the shipment against the packing slip and the freight company bill of lading. Verify that all units and packages have been received. Inspect the packaging of each package and each unit for damages. Insure that the carrier makes proper notation of all damages or shortage on all bill of lading papers. Concealed damage should be reported to the freight company within 15 days. If not filed within 15 days the freight company can deny all claims.

Note: Notify Enertech Global, LLC shipping department of all damages within 15 days. It is the responsibility of the purchaser to file all necessary claims with the freight company.

Un-packaging

Enertech units are mounted to wooden pallets for easy handling during shipment and installation. Units are protected during shipment with durable cardboard corner posts, top and air coil panels. Shrink wrap is applied covering the entire unit and attachment to the pallet.

Upon receipt of the unit carefully remove the shrink wrap. Using a box cutter slit the shrink wrap on the cardboard top and corner posts. Use caution to not damaged the finished surface of the unit. Keep all cardboard or other packaging material for safe storage and transport to the job site prior to installation.

Remove the front service panel to locate technical documents; manuals, bulletins or instructions and accessory items; HWG piping kits, and strainers.

⚠ CAUTION ⚠

Do not operate the Geothermal Heat Pump unit during building construction phase.

Unit Protection

Protect units from damage and contamination due to plastering (spraying), painting and all other foreign materials that may be used at the job site. Keep all units covered on the job site with either the original packaging or equivalent protective covering. Cap or recap unit connections and all piping until unit is installed. Precautions must be taken to avoid physical damage and contamination which may prevent proper start-up and may result in costly equipment repair.

Storage

All geothermal units should be stored inside in the original packaging in a clean, dry location. Units should be stored in an upright position at all times. Units should not be stacked unless specially noted on the packaging.

Removal and Disposal

All Geothermal units removed from service should have all components, oils, antifreeze and refrigerants properly disposed of according to local and national environmental recycling codes, regulations, standards and rules.

Pre-Installation

Special care should be taken in locating the geothermal unit. Installation location chosen should include adequate service clearance around the unit. All units should be placed on a formed plastic air pad, or a high density, closed cell polystyrene pad slightly larger than the base of the unit. If units are being placed on racking, the unit must be placed on a solid foundation. All units should be located in an indoor area where the ambient temperature will remain above 55°F and should be located in a way that piping and ductwork or other permanently installed fixtures do not have to be removed for servicing and filter replacement.

Section 2: Installation Introduction

⚠ CAUTION ⚠

Ground and hydronic loops must be antifreeze protected. Insufficient amounts of antifreeze may cause severe damage and may void warranty. Hydronic loop antifreeze must be non-flammable. Never operate with ground or hydronic loop flow rates less than specified. Continuous operation at low flow or no flow may cause severe damage and may void warranty.

⚠ CAUTION ⚠

If insufficient antifreeze used in either source or load sides, a flow switch must be field installed. Field Kit 28K053-01NN is available

⚠ CAUTION ⚠

GEOTHERMAL equipment is designed for indoor installation only. DO NOT install or store unit in a corrosive environment or in a location where temperature and humidity are subject to extremes. Equipment is not certified for outdoor applications. Such installation will void all warranties.

Pre-Installation Steps

1. Compare the electrical data on the unit nameplate with packing slip and ordering information to verify that the correct unit has been shipped.
2. Inspect all electrical connections and wires. Connections must be clean and tight at the terminals, and wires should not touch any sharp edges or copper pipe.
3. Verify that all refrigerant tubing is free of dents and kinks. Refrigerant tubing should not be touching other unit components.
4. Before unit start-up, read all manuals and become familiar with unit components and operation. Thoroughly check the unit before operating.

⚠ CAUTION ⚠

Brazed plate heat exchangers are not designed to be used for open loop/well water applications or any applications when antifreeze is not used. A unit with a coaxial heat exchanger should be used for open loop applications. If using a brazed plate heat exchanger on an open application, a secondary heat exchanger must be installed with antifreeze in the piping between the unit and the secondary heat exchanger.

NOTICE

These units feature braze-plate heat exchangers. Enertech requires that a strainer be installed on the water inlet of the source side and load side circuits. A strainer with a size of 16-20 mesh minimum should be used. For your convenience, a strainer and connection hardware have been included with the unit.

Components

Master Contactor: Energizes Compressor and optional Hydronic Pump and/or Desuperheater pump package.

Logic Board: Logic Board operates the compressor and protects unit by locking out when safety switches are engaged. It also provides fault indicator(s).

Terminal Strip: Provides connection to the thermostat or other accessories to the low voltage circuit.

Transformer: Converts incoming (source) voltage to 24V AC.

Low Voltage Breaker: Attached directly to transformer, protects the transformer and low voltage circuit.

Reversing Valve: Controls the cycle of the refrigerant system (heating or cooling). Energized in cooling mode.

High Pressure Switch: Protects the refrigerant system from high refrigerant pressure, by locking unit out if pressure exceeds setting.

Low Pressure Switch: Protects the refrigerant system from low suction pressure, if suction pressure falls below setting.

Flow Switch (Freeze Protection Device): Protects the water heat exchanger from freezing, by shutting down compressor if water flow decreases.

Compressor (Copeland Scroll): Pumps refrigerant through the heat exchangers and pressurizes the refrigerant, which increases the temperature of the refrigerant.

⚠ CAUTION ⚠

Before drilling or driving any screws into cabinet, check to be sure the screw will not hit any internal parts or refrigerant lines.

Section 3: Installation Considerations

Consumer Instructions

Dealer should instruct the consumer in proper operation, maintenance, filter replacements, thermostat and indicator lights. Also provide the consumer with the manufacturer's Owner's Manual for the equipment being installed.

Enertech Global D-I-Y Policy

Enertech Global's geothermal heat pumps and system installations may include electrical, refrigerant and/or water connections. Federal, state and local codes and regulations apply to various aspects of the installation. Improperly installed equipment can lead to equipment failure and health/safety concerns. For these reasons, only qualified technicians should install a Enertech Global built geothermal system.

Because of the importance of proper installation, Enertech Global does not sell equipment direct to homeowners. Internet websites and HVAC outlets may allow for purchases directly by homeowners and do-it-yourselfers, but Enertech Global offers no warranty on equipment that is purchased via the internet or installed by persons without proper training.

Enertech Global has set forth this policy to ensure installations of Enertech Global geothermal systems are done safely and properly. The use of well-trained, qualified technicians helps ensure that your system provides many years of comfort and savings.

Equipment Installation

Special care should be taken in locating the unit. All units should be placed on a formed plastic air pad, or a high density, closed cell polystyrene pad slightly larger than the base of the unit. All units should be located in an indoor area where the ambient temperature will remain above 55°F and should be located in a way that piping and ductwork or other permanently installed fixtures do not have to be removed for servicing and filter replacement.

Electrical

All wiring, line and low voltage, should comply with the manufacturer's recommendations, The National Electrical Code, and all local codes and ordinances.

Thermostat

Thermostats should be installed approximately 54 inches off the floor on an inside wall in the return air pattern and where they are not in direct sunlight at anytime.

Loop Pumping Modules

Must be wired to the heat pump's electric control box. A pump module connection block, connected to the master contactor, and circuit breaker is provided to connect the Pump Module wiring.

Desuperheater Package

Water heating is standard on all residential units (units may be ordered without). It uses excess heat during both heating and cooling cycles, to provide hot water for domestic needs. A double wall desuperheater exchanger (coil) located between the compressor and the reversing valve, extracts superheated vapor to heat domestic water; still satisfying its heating and cooling needs. The water circulation pump comes pre-mounted in all residential units, but must be electrically connected to the master contactor. Leaving it disconnected ensures that the pump will not run without a water supply.

The Desuperheater package can make up to 60% (depending on heat pump usage) of most domestic water needs, but a water heater is still recommended.

Desuperheater Piping

All copper tubes & fittings should be 5/8" O.D (1/2" nom) minimum with a maximum of 50ft separation. Piping should be insulated with 3/8" wall closed cell insulation.

Note: Copper is the only approved material for piping the desuperheater.

Unit Placement

When installing a geothermal heating and cooling unit, there are several items the installer should consider before placing the equipment.

1. **Service Access.** Is there enough space for service access? A general rule of thumb is at least 2 feet in the front and 2 feet on at least one side.
2. **Unit Air Pad.** All geothermal heating and cooling equipment should be placed on either a formed plastic air pad, or a high density, closed cell polystyrene pad. This helps eliminate vibration noise that could be transmitted through the floor
3. If units are being placed on racking, the unit must be placed on a solid foundation covering the full base of the unit. Also, utilize a foam pad between the unit and the rack.
4. The installer must verify that all applicable wiring, piping, and accessories are correct and on the job site.

Section 3: Installation Considerations

Pre-Installation

Before you fully install the geothermal equipment, it is recommended you go through this quick checklist before placing the equipment.

- Fully inspect the unit after unpacking.
- Locate the Unit Start-Up form from this manual and have it available as the unit installation proceeds.

Buffer Tanks

Virtually all water-to-water heat pumps used for hydronic applications require a buffer tank to prevent equipment short cycling, and to allow lower flow rates through the water-to-water unit than through the hydronic delivery system. The following are considerations for buffer tank sizing.

- The size of the buffer tank should be determined based upon the predominant use of the water-to-water equipment (heating or cooling).
- The size of the buffer tank is based upon the lowest operating stage of the equipment. For example, a water-to-water heat pump with a two-stage compressor or two compressors may be sized for first stage capacity, reducing the size of the tank (two-stage aquastat required)
- Pressurized buffer tanks are sized differently than non-pressurized tanks (see guidelines listed below).

Pressurized buffer tanks for predominately heating applications should be sized at one (1) U.S. gallon per 1,000 Btuh of heating capacity (10 gallons per ton may also be used) at the maximum entering source water temperature (EST) and the minimum entering load water temperature (ELT), the point at which the water-to-water unit has the highest heating capacity, usually 50-70°F EST and 80-90°F ELT.

For predominately cooling applications, pressurized buffer tanks should be sized at one (1) U.S. gallon per 1,000 Btuh of cooling capacity (10 U.S. gallons per ton may also be used) at the minimum EST and the maximum ELT, the point at which the water-to-water unit has the highest cooling capacity, usually 50-70°F EST and 50-60°F ELT.

Select the size of the tank based upon the larger of the calculations (heating or cooling).

Non-pressurized buffer tanks must also be sized based upon predominate use (heating or cooling) and based upon the lowest capacity stage. Requirements for storage are less according to the manufacturer of the HSS series non-pressurized buffer tank. Using the same conditions for maximum heating and cooling capacity mentioned above, non-pressurized buffer tanks require 6 U.S. gallons per ton.

Section 3: Installation Considerations

Guidelines For Heating Mode Operation

Enertech recommends the aquastat setting not be set above 110°F for the storage tank temperature. Excessive vibration and part failure can occur at higher than recommended temperature settings. The higher operating temperatures cause substantial efficiency and capacity reductions.

The performance is negatively affected as the unit operates at the higher water temperatures and it benefits the unit and the homeowner to operate at or below the recommended water temperature of 110°F.

The illustration below shows the parameters which are safe for compressor operation. Based on the leaving load water of 120°F, the loop would have to maintain 35°F to operate within the acceptable operating conditions for the compressor. Once your loop temperatures drop below 35°F, the acceptable leaving load temperature drops below 120°F. If you are designing loops for 30°F, the recommended leaving load temperature is 110°F.

With the lower efficiency created by higher water temperatures, the output capacity of the unit is decreased along with the efficiency. When operating at the higher entering water temperature the heat of extraction is significantly reduced, as well. In order to maintain the needed capacity, more of the heat is coming from the compressor working harder to compress the refrigerant. Because the water-to-water machines have become so popular for providing heated water for a multitude of uses, we've provided the above chart for reference.

The obvious correlation is that the warmer the Source Entering Water Temperature, the hotter the Load Leaving Water Temperature can be, to a point. R410A can only handle up to about 125°F Load Leaving Water Temperature before putting the compressor at risk.

Actual usage, and choices of heat distribution devices need to follow the acceptable operating conditions presented in the chart. If a question arises, please consult the Technical Services Department.

SCROLL COMPRESSOR OPERATING CONDITIONS (WATER TO WATER)
HEATING MODE OPERATION

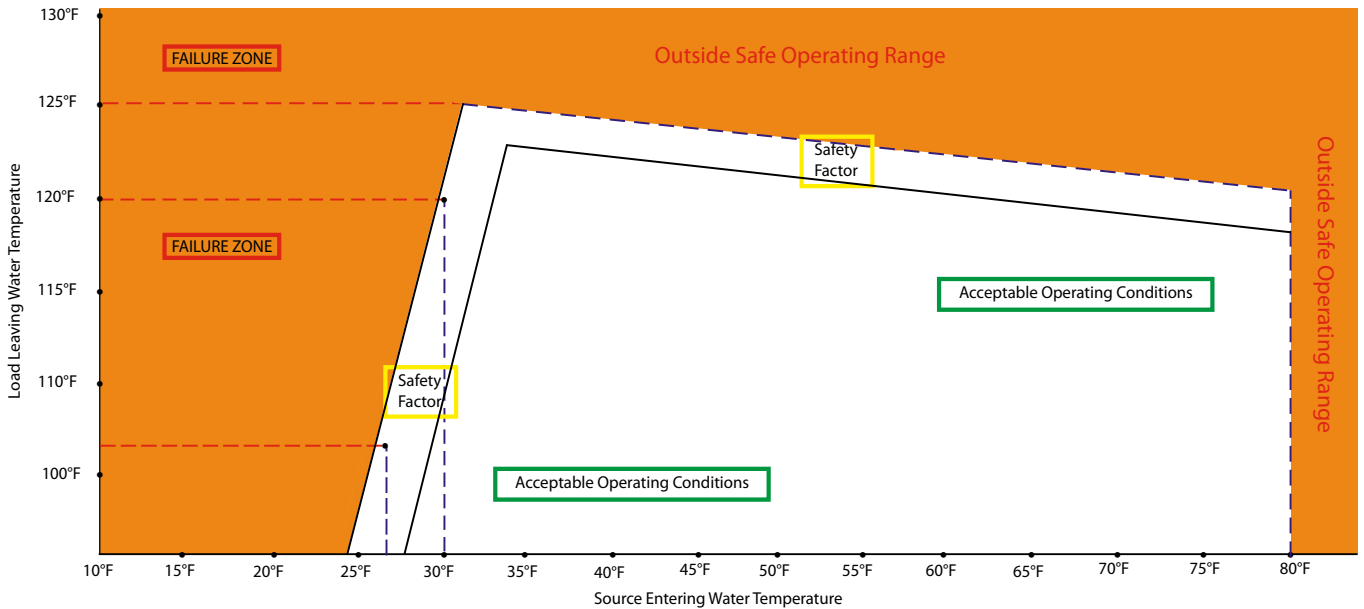

Section 4: Unit Data Information

Unit Dimensional Data

| Water Connections | 3-7 Ton | 10 Ton |
|----------------------|----------|----------|
| Source Loop (Copper) | 1.25 MPT | 1.25 MPT |
| Source Loop (Cupro) | 1.00 FPT | 1.00 FPT |
| Load Loop | 1.25 MPT | 1.25 MPT |
| Hot Water Generator | 1.00 FPT | 1.00 FPT |

* All measurements in inches

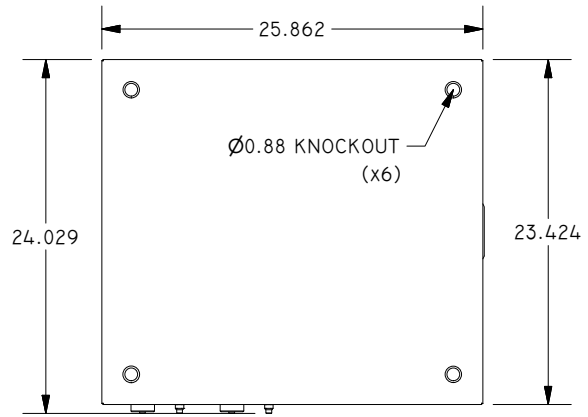

3-7 TON SINGLE COMPRESSOR UNIT
TOP VIEW

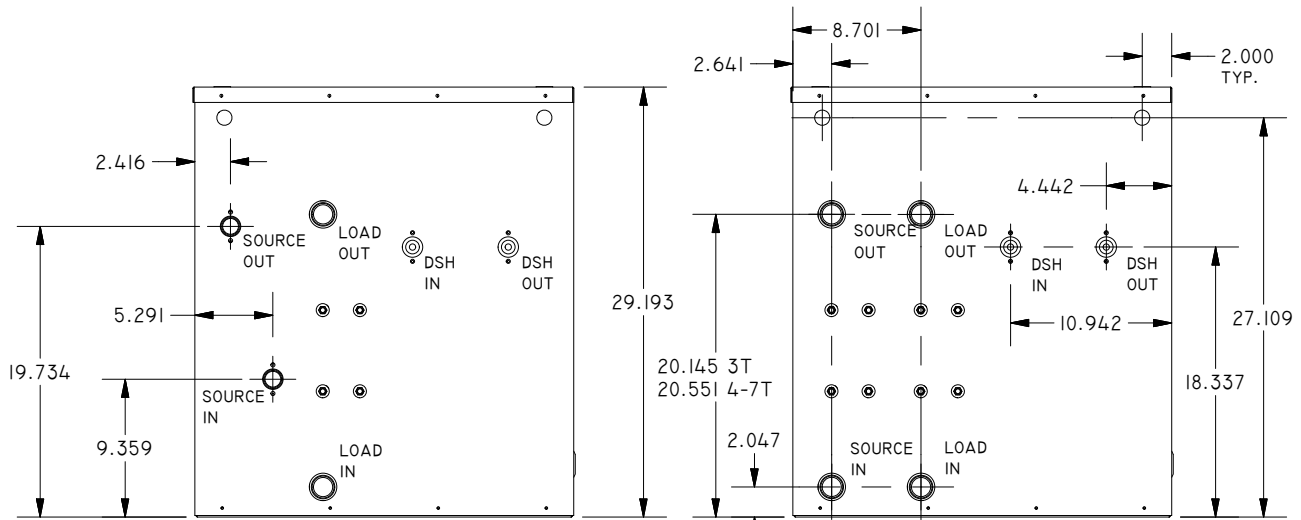

3-7 TON SINGLE COMPRESSOR UNIT
LEFT SIDE *CUPRO

3-7 TON SINGLE COMPRESSOR UNIT
LEFT SIDE *COPPER

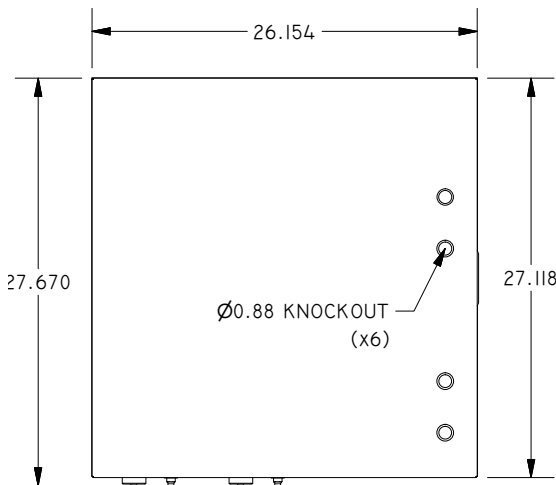

10 TON DUAL COMPRESSOR UNIT
TOP VIEW

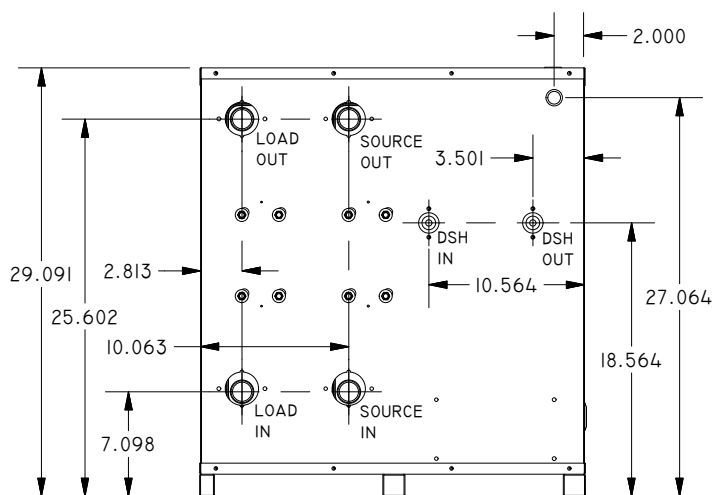

10 TON DUAL COMPRESSOR UNIT
LEFT SIDE

Section 4: Unit Data Information

Unit Electrical Data

| Model | Voltage Code/ HWG Option | 60 Hz Power | | Compressor | | HWG Pump FLA | Ext. Loop Pump FLA | Total Unit FLA | Min Circuit AMPS | Max Brkr HACR |
|-------|--------------------------|-------------|-------|------------|----------|--------------|--------------------|----------------|------------------|---------------|
| | | Volts | Phase | LRA | RLA | | | | | |
| WS036 | 00 | 208/230 | 1 | 112.0 | 17.9 | 0.0 | 0.0 | 17.9 | 22.4 | 40 |
| | 01 | 208/230 | 1 | 112.0 | 17.9 | 0.3 | 0.0 | 18.2 | 22.7 | 40 |
| | 10 | 208/230 | 1 | 112.0 | 17.9 | 0.0 | 4.0 | 21.9 | 26.4 | 40 |
| | 11 | 208/230 | 1 | 112.0 | 17.9 | 0.3 | 4.0 | 22.2 | 26.7 | 45 |
| | 20 | 208/230 | 3 | 88.0 | 13.2 | 0.0 | 0.0 | 13.2 | 16.5 | 30 |
| | 21 | 208/230 | 3 | 88.0 | 13.2 | 0.3 | 0.0 | 13.5 | 16.8 | 30 |
| | 30/35 | 460 | 3 | 44.0 | 6.0 | 0.0 | 0.0 | 6.0 | 7.5 | 15 |
| WS048 | 00 | 208/230 | 1 | 134.0 | 25.4 | 0.0 | 0.0 | 25.4 | 31.8 | 50 |
| | 01 | 208/230 | 1 | 134.0 | 25.4 | 0.3 | 0.0 | 25.7 | 32.1 | 50 |
| | 10 | 208/230 | 1 | 134.0 | 25.4 | 0.0 | 5.5 | 30.9 | 37.3 | 60 |
| | 11 | 208/230 | 1 | 134.0 | 25.4 | 0.3 | 5.5 | 31.2 | 37.6 | 60 |
| | 20 | 208/230 | 3 | 110.0 | 15.9 | 0.0 | 0.0 | 15.9 | 19.9 | 35 |
| | 21 | 208/230 | 3 | 110.0 | 15.9 | 0.3 | 0.0 | 16.2 | 20.2 | 35 |
| | 30/35 | 460 | 3 | 52.0 | 7.1 | 0.0 | 0.0 | 7.1 | 8.9 | 15 |
| WS060 | 00 | 208/230 | 1 | 178.0 | 28.3 | 0.0 | 0.0 | 28.3 | 35.4 | 60 |
| | 01 | 208/230 | 1 | 178.0 | 28.3 | 0.3 | 0.0 | 28.6 | 35.7 | 60 |
| | 10 | 208/230 | 1 | 178.0 | 28.3 | 0.0 | 5.5 | 33.8 | 40.9 | 60 |
| | 11 | 208/230 | 1 | 178.0 | 28.3 | 0.3 | 5.5 | 34.1 | 41.2 | 60 |
| | 20 | 208/230 | 3 | 136.0 | 19.2 | 0.0 | 0.0 | 19.2 | 24.0 | 40 |
| | 21 | 208/230 | 3 | 136.0 | 19.2 | 0.3 | 0.0 | 19.5 | 24.3 | 40 |
| | 30/35 | 460 | 3 | 66.1 | 8.7 | 0.0 | 0.0 | 8.7 | 10.9 | 20 |
| WS072 | 00 | 208/230 | 1 | 148.0 | 32.1 | 0.0 | 0.0 | 32.1 | 40.1 | 70 |
| | 01 | 208/230 | 1 | 148.0 | 32.1 | 0.3 | 0.0 | 32.4 | 40.4 | 70 |
| | 10 | 208/230 | 1 | 148.0 | 32.1 | 0.0 | 5.5 | 37.6 | 45.6 | 70 |
| | 11 | 208/230 | 1 | 148.0 | 32.1 | 0.3 | 5.5 | 37.9 | 45.9 | 70 |
| | 20 | 208/230 | 3 | 164.0 | 23.2 | 0.0 | 0.0 | 23.2 | 29.0 | 50 |
| | 21 | 208/230 | 3 | 164.0 | 23.2 | 0.3 | 0.0 | 23.5 | 29.3 | 50 |
| | 30/35 | 460 | 3 | 75.0 | 11.2 | 0.0 | 0.0 | 11.2 | 14.0 | 25 |
| WS084 | 00 | 208/230 | 1 | 185.0 | 32.1 | 0.0 | 0.0 | 32.1 | 40.1 | 70 |
| | 01 | 208/230 | 1 | 185.0 | 32.1 | 0.3 | 0.0 | 32.4 | 40.4 | 70 |
| | 10 | 208/230 | 1 | 185.0 | 32.1 | 0.0 | 5.5 | 37.6 | 45.6 | 70 |
| | 11 | 208/230 | 1 | 185.0 | 32.1 | 0.3 | 5.5 | 37.9 | 45.9 | 70 |
| | 20 | 208/230 | 3 | 164.0 | 25.0 | 0.0 | 0.0 | 25.0 | 31.3 | 50 |
| | 21 | 208/230 | 3 | 164.0 | 25.0 | 0.3 | 0.0 | 25.3 | 31.6 | 50 |
| | 30/35 | 460 | 3 | 100.0 | 12.2 | 0.0 | 0.0 | 12.2 | 15.3 | 25 |
| WD120 | 00 | 208/230 | 1 | 158.0 ea. | 30.1 ea. | 0.0 | 0.0 | 60.2 | 67.7 | 90 |
| | 01 | 208/230 | 1 | 158.0 ea. | 30.1 ea. | 0.3 | 0.0 | 60.5 | 68.0 | 90 |
| | 10 | 208/230 | 1 | 158.0 ea. | 30.1 ea. | 0.0 | 5.5 | 65.7 | 73.2 | 100 |
| | 11 | 208/230 | 1 | 158.0 ea. | 30.1 ea. | 0.3 | 5.5 | 66.0 | 73.5 | 100 |
| | 20 | 208/230 | 3 | 155.0 ea. | 20.5 ea. | 0.0 | 0.0 | 41.0 | 46.1 | 60 |
| | 21 | 208/230 | 3 | 155.0 ea. | 20.5 ea. | 0.3 | 0.0 | 41.3 | 46.4 | 60 |
| | 30/35 | 460 | 3 | 75.0 ea. | 9.6 ea. | 0.0 | 0.0 | 19.2 | 21.6 | 30 |

Notes:

1. All line and low voltage wiring must adhere to the National Electrical Code and local codes, whichever is the most stringent.

2. In determining the correct supply wire size and maximum length, reference NFPA 70, Section 310. If the calculation is close to the maximum allowable ampacity of a particular wire size, use the next size up. This will ensure that no adverse effects occur, such as light dimming and/or shortened compressor life.

3. Min/Max Voltage: 208/230/60 = 187-252, 460/60 = 432-502

4. See Wiring Diagrams for proper 460V and 575V power.

*The external loop pump FLA is based on a maximum of three UP26-116F-230V pumps (1/2hp) for 048-120 and two pumps for 036.

NOTE: Proper Power Supply Evaluation

When any compressor bearing unit is connected to a weak power supply, starting current will generate a significant “sag” in the voltage which reduces the starting torque of the compressor motor and increases the start time. This will influence the rest of the electrical system in the building by lowering the voltage to the lights. This momentary low voltage causes “light dimming”. The total electrical system should be evaluated with an electrician and HVAC technician. The evaluation should include all connections, sizes of wires, and size of the distribution panel between the unit and the utility’s connection. The transformer connection and sizing should be evaluated by the electric utility provider.

Section 5: Unit Piping Installation

Water Quality

The quality of the water used in geothermal systems is very important. In closed loop systems the dilution water (water mixed with antifreeze) must be of high quality to ensure adequate corrosion protection. Water of poor quality contains ions that make the fluid “hard” and corrosive. Calcium and magnesium hardness ions build up as scale on the walls of the system and reduce heat transfer. These ions may also react with the corrosion inhibitors in glycol based heat transfer fluids, causing them to precipitate out of solution and rendering the inhibitors ineffective in protecting against corrosion. In addition, high concentrations of corrosive ions, such as chloride and sulfate, will eat through any protective layer that the corrosion inhibitors form on the walls of the system.

⚠ CAUTION ⚠

Brazed plate heat exchangers are not designed to be used for open loop/well water applications or any applications when antifreeze is not used. A unit with a coaxial heat exchanger should be used for open loop applications.

If using a brazed plate heat exchanger on an open application, a secondary heat exchanger must be installed with antifreeze in the piping between the unit and the secondary heat exchanger.

Ideally, de-ionized water should be used for dilution with antifreeze solutions since de-ionizing removes both corrosive and hardness ions. Distilled water and zeolite softened water are also acceptable. Softened water, although free of hardness ions, may actually have increased concentrations of corrosive ions and, therefore, its quality must be monitored. It is recommended that dilution water contain less than 100 PPM calcium carbonate or less than 25 PPM calcium plus magnesium ions; and less than 25 PPM chloride or sulfate ions.

In an open loop system the water quality is of no less importance. Due to the inherent variation of the supply water, it should be tested prior to making the decision to use an open loop system. Scaling of the heat exchanger and corrosion of the internal parts are two of the potential problems. The Department of Natural Resources or your local municipality can direct you to the proper testing agency. Please see following table for guidelines.

Water Quality

| Potential Problem | Chemical(s) or Condition | Range for Copper Heat Exchangers | Cupro-Nickel Heat Exchanger Ranges | Stainless Steel Heat Exchanger Ranges |
|-------------------|--|----------------------------------|------------------------------------|---------------------------------------|
| Scaling | Calcium & Magnesium Carbonate | Less than 350 ppm | Less than 350 ppm | Less than 0.1 ppm |
| Corrosion | pH Range | 7 - 9 | 5 - 9 | 7 - 9 |
| | Total Dissolved Solids | Less than 1000 ppm | Less than 1500 ppm | No rigid setpoint |
| | Ammonia, Ammonium Hydroxide | Less than 0.5 ppm | Less than 0.5 ppm | No Limit |
| | Ammonium Chloride, Ammonium Nitrate | Less than 0.5 ppm | Less than 0.5 ppm | Less than 2-20 ppm |
| | Calcium/Sodium Chloride <small>See Note 4</small> | Less than 125 ppm | Less than 125 ppm | None Allowed |
| | Chlorine | Less than 0.5 ppm | Less than 0.5 ppm | Less than 1 ppm* |
| | Hydrogen Sulfide | None Allowed | None Allowed | Less than 0.05 ppm |
| Biological Growth | Iron Bacteria | None Allowed | None Allowed | None Allowed |
| | Iron Oxide | Less than 1 ppm | Less than 1 ppm | Less than 0.2 ppm |
| Erosion | Suspended Solids - Note 5 | Less than 10 ppm | Less than 10 ppm | 16-20 mesh strainer recommended |
| | Water Velocity | Less than 8 ft/s | Less than 12 ft/s | Less than 5.5 m/s in the port |

* Chlorine can not be used with 304 Stainless Steel.

Notes

- Hardness in ppm is equivalent to hardness in mg/l.
- Grains/gallon = ppm divided by 17.1.
- Copper and cupro-nickel heat exchangers are not recommended for pool applications for water outside the range of the table. Secondary heat exchangers are required for applications not meeting the requirements shown above.
- Saltwater applications (approx. 25,000 ppm) require secondary heat exchangers due to copper piping between the heat exchanger and the unit fittings.
- Filter for maximum of 600 micron size.

Section 5: Unit Piping Installation

Interior Piping

All interior piping must be sized for proper flow rates and pressure loss. Insulation should be used on all inside piping when minimum loop temperatures are expected to be less than 50°F. Use the table below for insulation sizes with different pipe sizes. All pipe insulation should be a closed cell and have a minimum wall thickness of 3/8". All piping insulation should be glued and sealed to prevent condensation and dripping. Interior piping may consist of the following materials: HDPE, copper, brass, or rubber hose (hose kit only).

Pipe Insulation

| Piping Material | Insulation Description |
|-----------------|------------------------|
| 1" IPS Hose | 1-3/8" ID - 3/8" Wall |
| 1" IPS PE | 1-1/4" ID - 3/8" Wall |
| 1-1/4" IPS PE | 1-5/8" ID - 3/8" Wall |
| 2" IPS PD | 2-1/8" ID - 3/8" Wall |

NOTICE

These units feature braze-plate heat exchangers. Enertech requires that a strainer be installed on the water inlet of the source side and load side circuits. A strainer with a size of 16-20 mesh minimum should be used. For your convenience, a strainer and connection hardware have been included with the unit.

Typical Single Compressor Unit Piping Connection

The following drawings indicate typical GSHP connections. Please refer to product dimensional drawings for actual fitting and port locations

WS Models

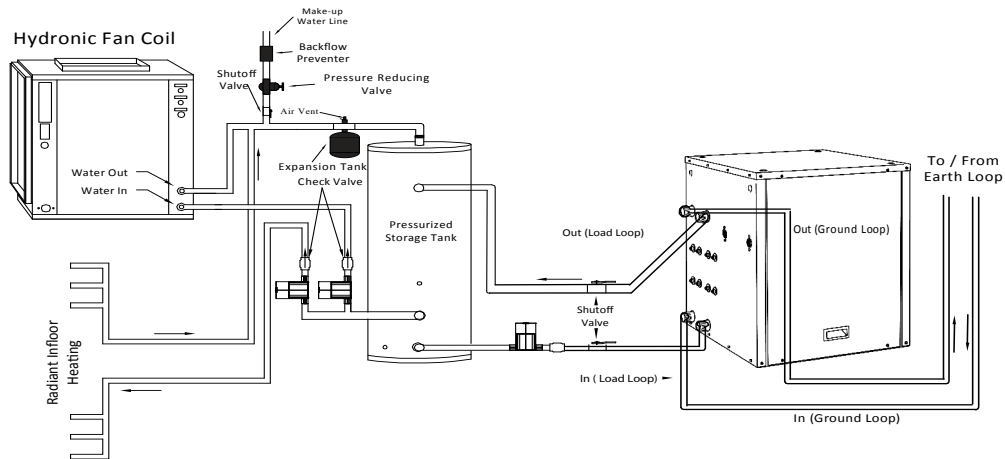

WD Models

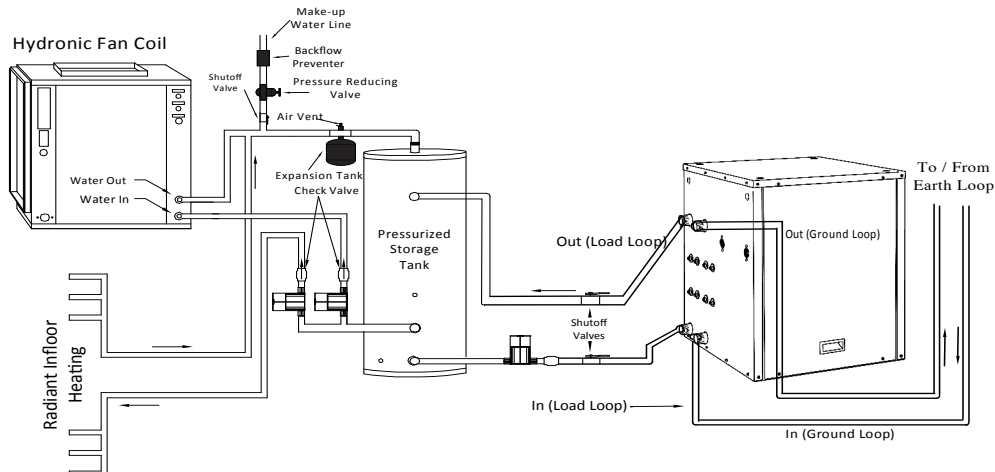

Section 5: Unit Piping Installation

Typical Pressurized Flow Center Installation

The flow centers are insulated and contain all flushing and circulation connections for residential and light commercial earth loops that require a flow rate of no more than 20 gpm. 1-1/4" fusion x 1" double o-ring fittings (AGA6PES) are furnished with the double o-ring flow centers for HDPE loop constructions. Various fittings are available for the double o-ring flow centers for different connections. A typical installation shown below will require the use of a hose kit. Matching hose kits come with double o-ring or NPT adapters to transition to 1" hose connection.

PVC is not recommended on pressurized systems.

Note: Threaded flow centers all have 1" FPT connections. Matching hose kits come with the AGBA55 adapter needed to transition from 1" FPT to 1" hose.

Typical Pressurized Flow Center Installation

The following drawings indicate typical GSHP connections. Please refer to product dimensional drawings for actual fitting and port locations

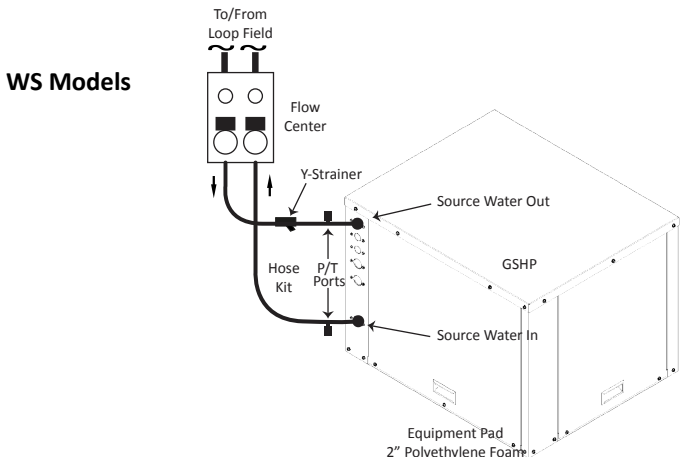
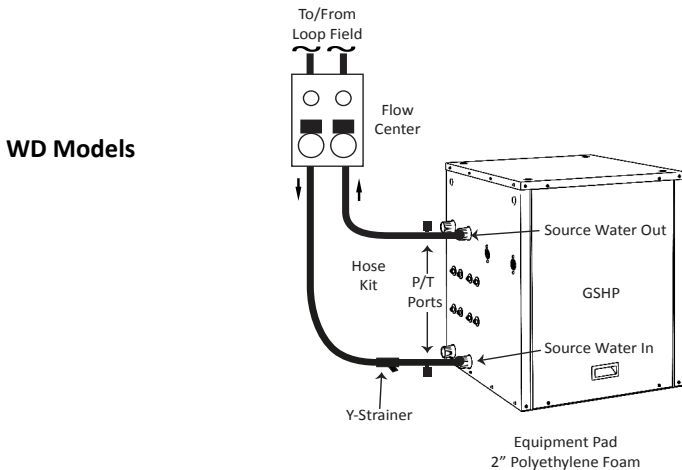

Typical Non-Pressurized Flow Center Installation

Standing column flow centers are designed to operate with no static pressure on the earth loop. The design is such that the column of water in the flow center is enough pressure to prime the pumps for proper system operation and pump reliability. The flow center does have a cap/seal, so it is still a closed system, where the fluid will not evaporate. If the earth loop header is external, the loop system will still need to be flushed with a purge cart. The non-pressurized flow center needs to be isolated from the flush cart during flushing because the flow center is not designed to handle pressure. Since this is a non-pressurized system, the interior piping can incorporate all the above-mentioned pipe material options (see interior piping), including PVC. The flow center can be mounted to the wall with the included bracket or mounted on the floor as long as it is properly supported. A typical installation shown below will require the use of a hose kit. Matching hose kits come with double o-ring or NPT adapters to transition to 1" hose connection.

Typical Non-Pressurized Flow Center Installation

The following drawings indicate typical GSHP connections. Please refer to product dimensional drawings for actual fitting and port locations

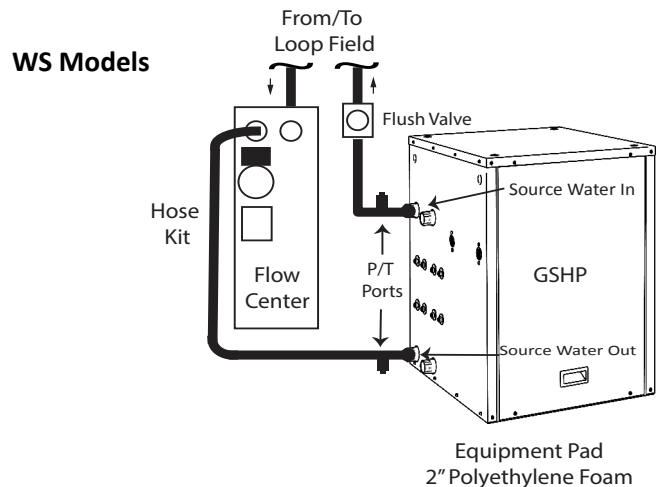
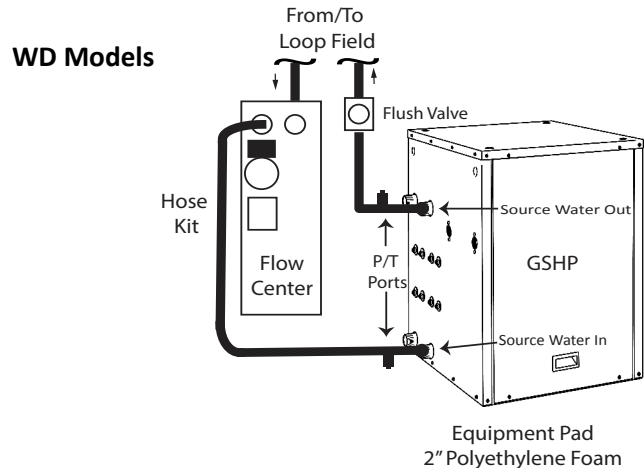

Section 5: Unit Piping Installation

Pressurized Flow Center and Pump Mounting

The flow center can be mounted with the flow paths either vertical or horizontal (see Figure 4). However, the flow center cannot be mounted on its back, upside down, or at an angle, as premature pump failure will occur when the pump shaft is not in the horizontal position.

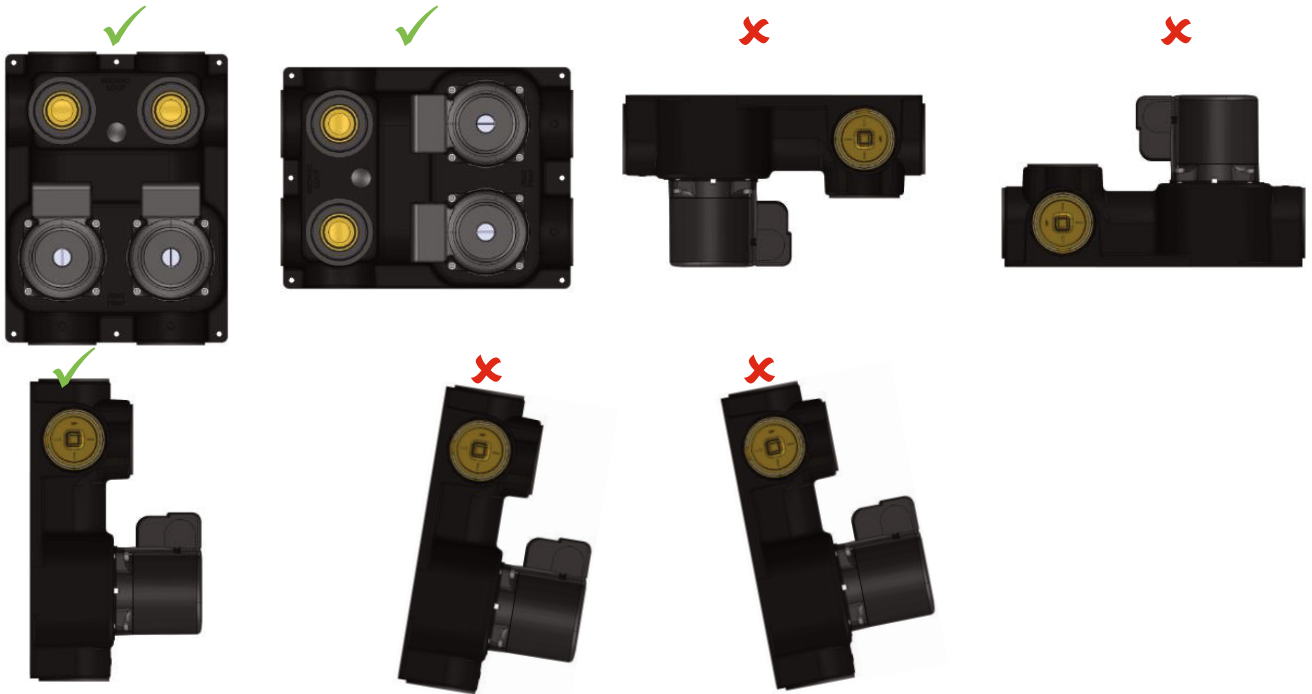

Figure 4: Acceptable mounting positions for Flo-Link and GPM series flow centers

Equally important to pump longevity is terminal box orientation. See Figure 5, 6, and 7 for proper control box orientation. The pump terminal box must be located in a position to avoid condensation running into the control box, and also to take advantage of the “weep holes” designed to drain any condensation that may have formed (Figure 6). “Weep holes” are located on three sides of the pump.

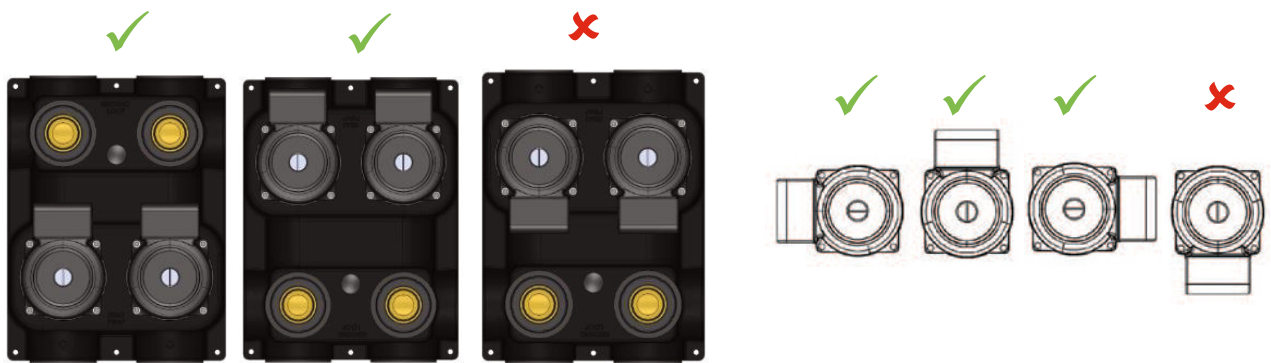

Figure 5: Acceptable terminal box locations for UPS26-99, UP26-99, and UP26-116 pumps.

Section 5: Unit Piping Installation

Open Loop Piping

Placement of the components for an open loop system are important when considering water quality and long term maintenance. The water solenoid valve should always be placed on the outlet of the heat pump, which will keep the heat exchanger under pressure when the unit is not operating. If the heat exchanger is under pressure, minerals will stay in suspension. Water solenoid valves are also designed to close against the pressure, not with the pressure. Otherwise, they tend to be noisy when closing.

A flow regulator should be placed after the water solenoid valve. Always check the product specification catalog for proper flow rate. A calculation must be made to determine the flow rate, so that the leaving water temperature does not have the possibility of freezing.

Other necessary components include a strainer, boiler drains for heat exchanger flushing, P/T ports and ball valves. Ball valves allow the water to be shut off for service, and also help when velocity noise is noticeable through the flow regulator. Spreading some of the pressure drop across the ball valves will lessen the velocity noise. Always double check flow rate at the P/T ports to make sure the ball valve adjustments have not lowered water flow too much, and essentially taken the flow regulator out of the equation. It's a good idea to remove the ball valve handles once the system is completed to avoid nuisance service calls.

Hose kits are optional, but make for an easier installation, since the P/T ports and connections are included. The hose also helps to isolate the heat pump from the piping system.

Since the heat pump can operate at lower waterflow on first stage, two stage units typically include two water solenoid valves to save water. The flow regulators should be sized so that when one valve is open the unit operates at first stage flow rate, and when both valves are open, the unit operates at full load flow rate. For example, a 4 ton unit needs approximately 4 GPM on first stage, and approximately 7 GPM at full load. The flow regulator after the first valve should be 4 GPM, and the flow regulator after the second valve should be 3 GPM. When both valves are open, the unit will operate at 7 GPM.

⚠ CAUTION ⚠

Brazed plate heat exchangers are not designed to be used for open loop/well water applications or any applications when antifreeze is not used. A unit with a coaxial heat exchanger should be used for open loop applications. If using a brazed plate heat exchanger on an open application, a secondary heat exchanger must be installed with antifreeze in the piping between the unit and the secondary heat exchanger.

Open Loop Piping Example

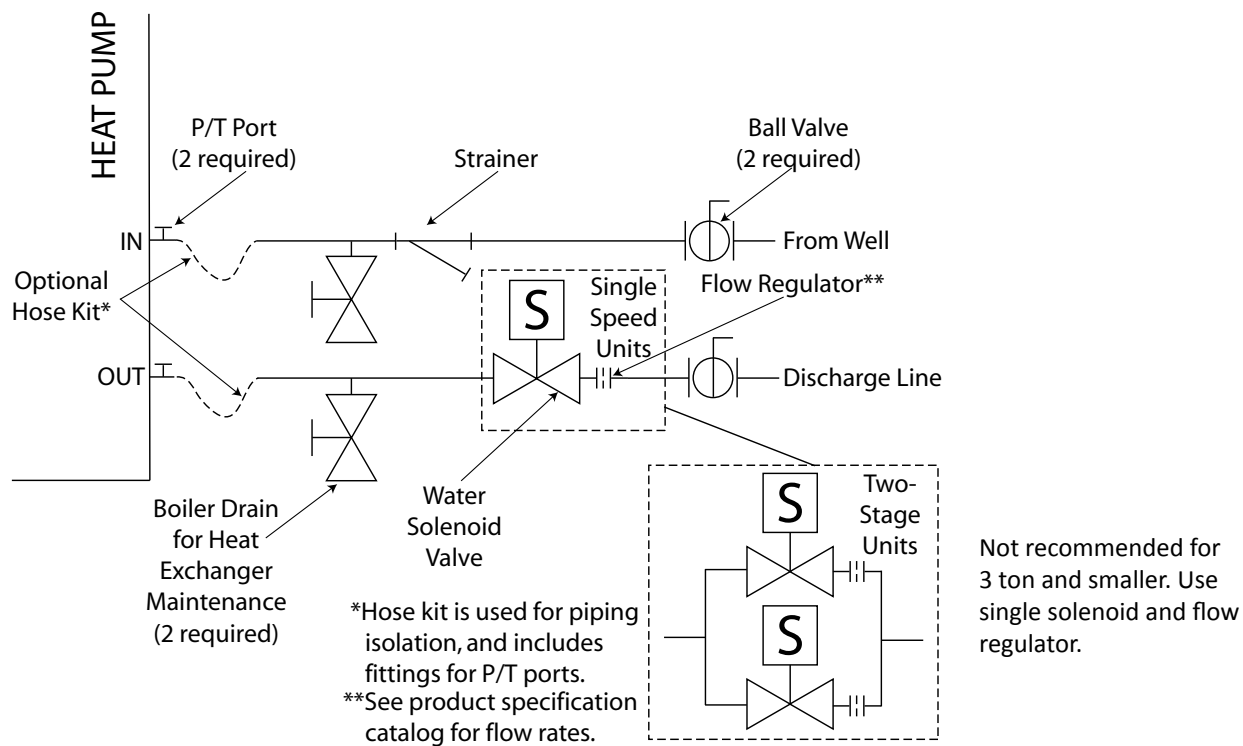

Not recommended for 3 ton and smaller. Use single solenoid and flow regulator.

Section 5: Unit Piping Installation

Typical Storage Tank Piping For Radiant Floor Heating

The following drawings indicate typical GSHP connections. Please refer to product dimensional drawings for actual fitting and port locations

WD Models

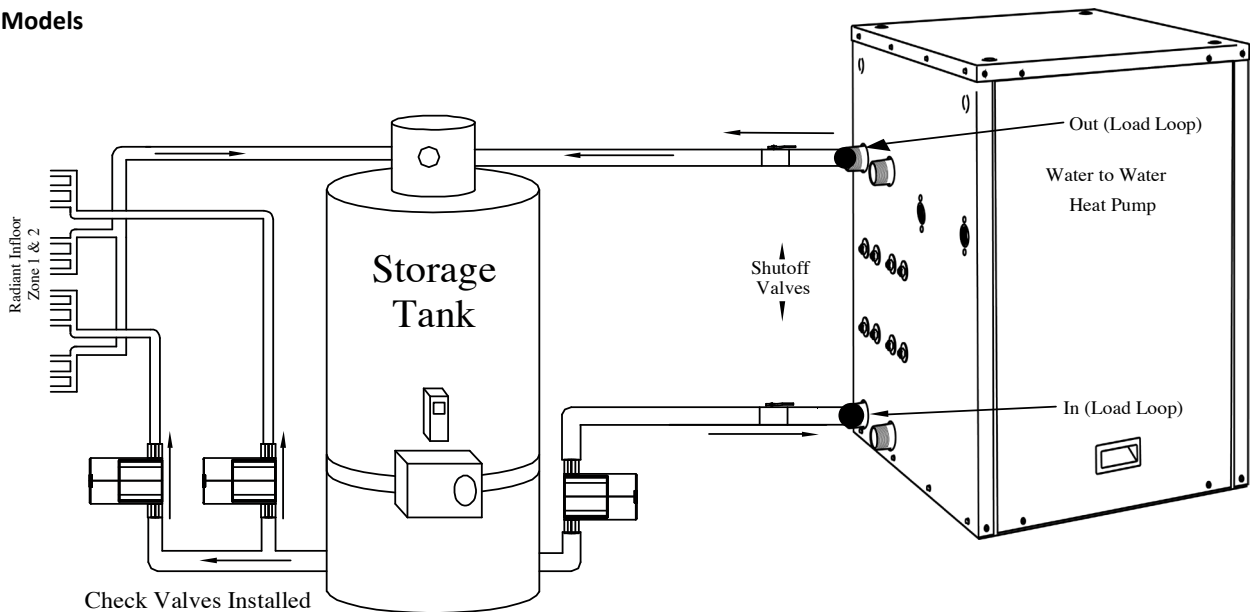

WS Models

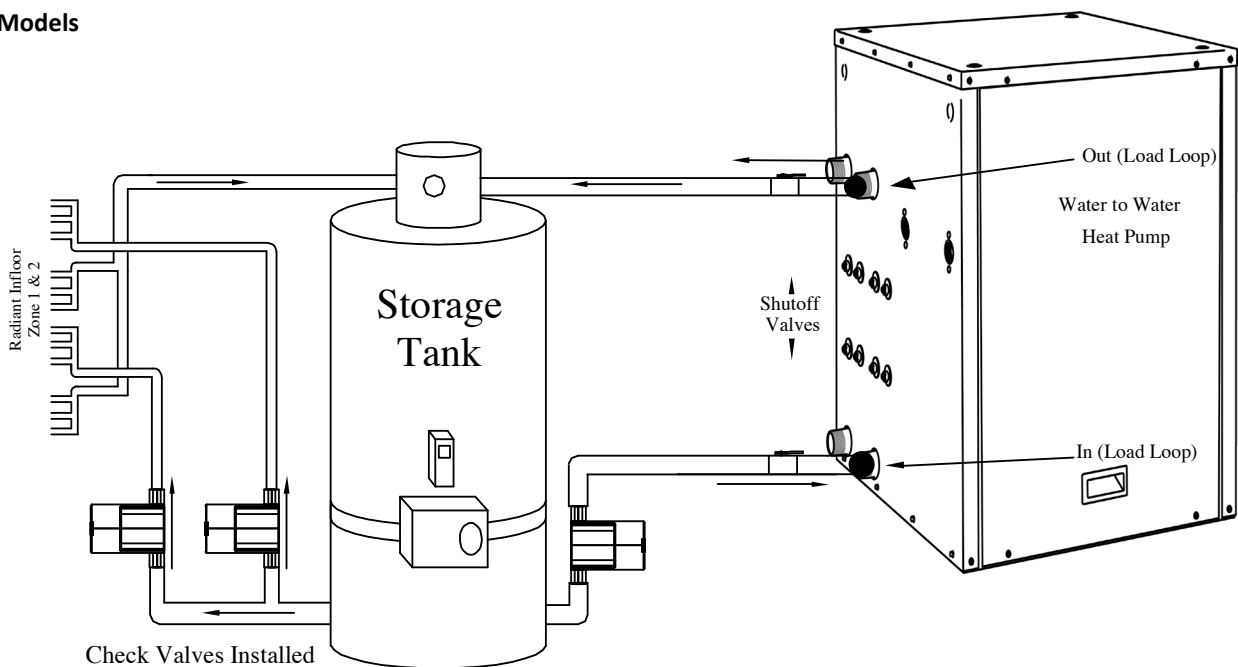

AP SMA Pump Sharing Module

The pump sharing module, part number APSMA, is designed to allow two units to share one flow center. With the APSMA module, either unit can energize the pump(s). Connect the units and flow center as shown in Figure 1. Figure 2 includes a schematic of the board. The module must be mounted in a NEMA enclosure or inside the unit control box. Local code supersedes any recommendations in this document.

Section 6: Antifreeze

Figure 1: APSMA Module Layout

Figure 1: Board Layout

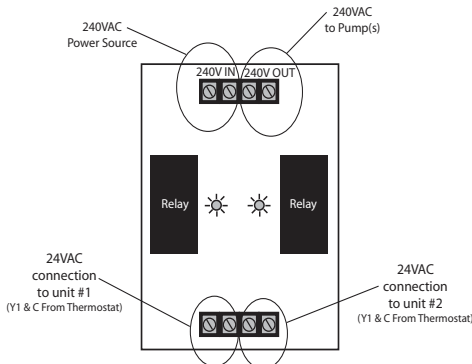
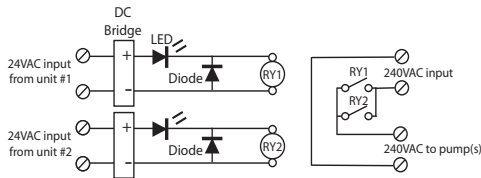

Figure 2: APSMA Module Wiring Schematic



Condensation Drain Connection

Connect the EZ-Trap to the condensate drain on the equipment drain connection. The condensation line must be trapped a minimum of 1.0" as shown on diagram. The condensation line should be pitched away from the unit a minimum of 1/4" per foot. The top of trap must be below the drain connection. For more information on installing EZ-Trap, see installation sheet that comes with the EZ-Trap Kit. Always install the air vent after the trap.

| Part Number | Description |
|-------------|------------------|
| ACDT1A | EZ-Trap 3/4" Kit |
| ACDT2A | EZ-Trap 1" Kit |

Note: Connect the drain through the trap to the condensation drain system in conformance to local plumbing codes.

Condensation Drain Connection

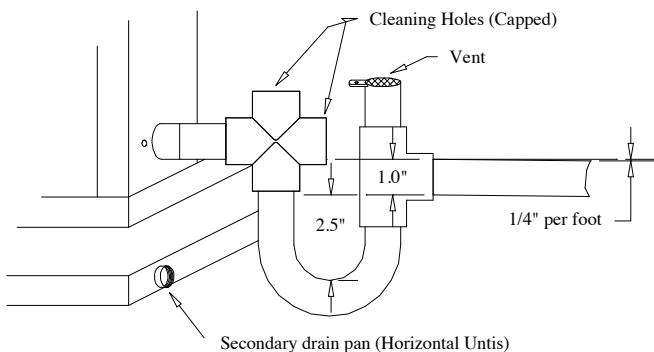

Antifreeze Overview

In areas where minimum entering loop temperatures drop below 40°F, or where piping will be routed through areas subject to freezing, antifreeze is required. Alcohols and glycols are commonly used as antifreeze. However, local and state/provincial codes supersede any instructions in this document. The system needs antifreeze to protect the coaxial heat exchanger from freezing and rupturing. Freeze protection should be maintained to 15°F below the lowest expected entering loop temperature. For example, if 30°F is the minimum expected entering loop temperature, the leaving loop temperature could be 22 to 25°F. Freeze protection should be set at 15°F (30-15 = 15°F). To determine antifreeze requirements, calculate how much volume the system holds. Then, calculate how much antifreeze will be needed by determining the percentage of antifreeze required for proper freeze protection. See Tables 1 and 2 for volumes and percentages. The freeze protection should be checked during installation using the proper hydrometer to measure the specific gravity and freeze protection level of the solution.

Antifreeze Characteristics

Selection of the antifreeze solution for closed loop systems require the consideration of many important factors, which have long-term implications on the performance and life of the equipment. Each area of concern leads to a different "best choice" of antifreeze. There is no "perfect" antifreeze. Some of the factors to consider are as follows (Brine = antifreeze solution including water):

Safety: The toxicity and flammability of the brine (especially in a pure form).

Cost: Prices vary widely.

Thermal Performance: The heat transfer and viscosity effect of the brine.

Corrosiveness: The brine must be compatible with the system materials.

Stability: Will the brine require periodic change out or maintenance?

Convenience: Is the antifreeze available and easy to transport and install?

Codes: Will the brine meet local and state/provincial codes?

Section 6: Antifreeze

The following are some general observations about the types of brines presently being used:

Methanol: Wood grain alcohol that is considered toxic in pure form. It has good heat transfer, low viscosity, is non-corrosive, and is mid to low price. The biggest down side is that it is flammable in concentrations greater than 25%.

Ethanol: Grain alcohol, which by the ATF (Alcohol, Tobacco, Firearms) department of the U.S. government, is required to be denatured and rendered unfit to drink. It has good heat transfer, mid to high price, is non-corrosive, non-toxic even in its pure form, and has medium viscosity. It also is flammable with concentrations greater than 25%. Note that the brand of ethanol is very important. Make sure it has been formulated for the geothermal industry. Some of the denaturants are not compatible with HDPE pipe (for example, solutions denatured with gasoline).

Propylene Glycol: Non-toxic, non-corrosive, mid to high price, poor heat transfer, high viscosity when cold, and can introduce micro air bubbles when adding to the system. It has also been known to form a “slime-type” coating inside the pipe. Food grade glycol is recommended because some of the other types have certain inhibitors that react poorly with geothermal systems. A 25% brine solution is a minimum required by glycol manufacturers, so that bacteria does not start to form.

Ethylene Glycol: Considered toxic and is not recommended for use in earth loop applications.

Potassium acetate (GS4): Considered highly corrosive (especially if air is present in the system) and has a very low surface tension, which causes leaks through most mechanical fittings. This brine is not recommended for use in earth loop applications.

Antifreeze Charging

Calculate the total amount of pipe in the system and use Table 1 to calculate the amount of volume for each specific section of the system. Add the entire volume together, and multiply that volume by the proper antifreeze percentage needed (Table 2) for the freeze protection required in your area. Then, double check calculations during installation with the proper hydrometer and specific gravity chart (Figure 3) to determine if the correct amount of antifreeze was added.

Table 1: Pipe Fluid Volume

| Type | Size | Volume Per 100ft US Gallons |
|--------|-------------|-----------------------------|
| Copper | 1" CTS | 4.1 |
| Copper | 1.25" CTS | 6.4 |
| Copper | 1.5" CTS | 9.2 |
| HDPE | .75 SDR11 | 3.0 |
| HDPE | 1" SDR11 | 4.7 |
| HDPE | 1.25" SDR11 | 7.5 |
| HDPE | 1.5: SDR11 | 9.8 |
| HDPE | 2" SDR11 | 15.4 |

Additional component volumes:

Unit coaxial heat exchanger = 1 Gallon

Flush Cart = 8-10 Gallons

10' of 1" Rubber Hose = 0.4 Gallons

Table 2: Antifreeze Percentages by Volume

| Antifreeze Type | Minimum Temperature for Freeze Protection | | | |
|---------------------------------|---|----------------|----------------|----------------|
| | 10°F -12.2°C | 15°F -9.4°C | 20°F -6.7°C | 25°F -3.9°C |
| ProCool (Ethanol) | 25% | 22% | 17% | 12% |
| Methanol | 25% | 21% | 16% | 10% |
| Propylene Glycol | 38% | 30% | 22% | 15% |
| Geothermal Transfer Fluid (GTF) | Mix according to manufacturer's directions on container label | | | |

Antifreeze solutions are shown in pure form - not premixed
GTF is a premixed Methanol solution

Section 6: Antifreeze

Figure 3: Antifreeze Specific Gravity

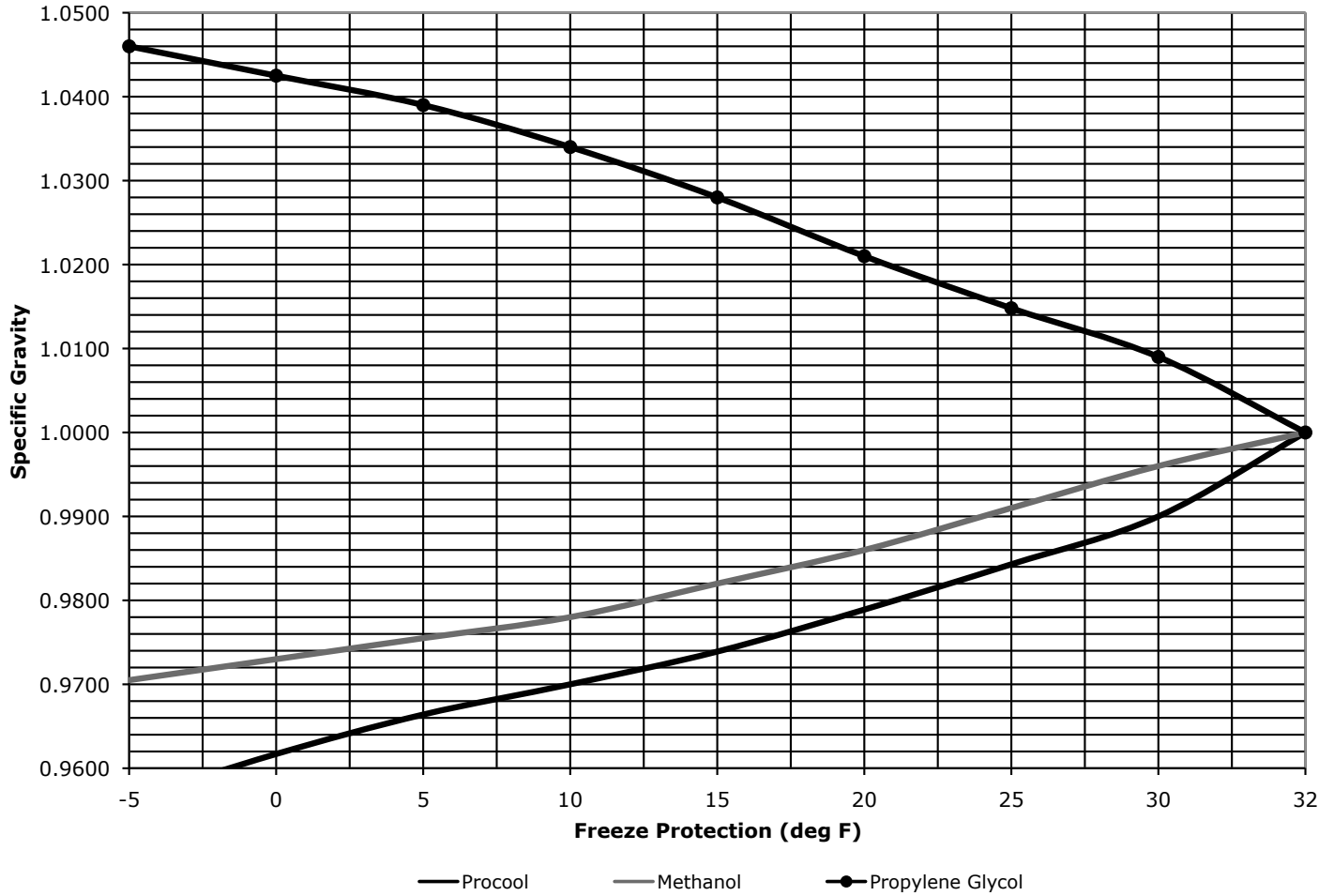

Notes:

1. Consult with your representative or distributor if you have any questions regarding antifreeze selection or use.
2. All antifreeze suppliers and manufacturers recommend the use of either de-ionized or distilled water with their products.

⚠ WARNING ⚠

Use extreme care when opening, pouring, and mixing flammable antifreeze solutions. Remote flames or electrical sparks can ignite undiluted antifreezes and vapors. Use only in a well ventilated area. Do not smoke when handling flammable solutions. Failure to observe safety precautions may result in fire, injury, or death. Never work with 100% alcohol solutions.

Section 7: Desuperheater Installation

Desuperheater Installation

Units that ship with the desuperheater function must be connected to the water heater/storage tank with the optionally offered Desuperheater Connection Kit or (as supplied by others) shown on the following sections of this manual.

Note: Desuperheater capacity is based on 0.4 GPM Flow per nominal ton at 90°F entering hot water temperature.

Note: Units that are shipped with a desuperheater do not have the desuperheater pump wires connected to the electrical circuit, to prevent accidentally running the pump while dry. Pump has to be connected to the electric circuit (master contactor) when the lines from the water heater are installed & air is removed.

CONTENTS OF THE DESUPERHEATER FITTING KIT:

- (1) p/n 20D052-01NN, Installation Instruction
- (1) p/n 33P211-01BN, 3/4"x 3/4"x 3/4" FPT Brass Tee
- (1) p/n 33P210-01NN, 3/4" Boiler Drain Valve
- (1) p/n 11080005001, 3/4" MPT x 3-1/2" Brass Nipple
- (3) p/n 11080006001, 1/2" SWT x 3/4" MPT Copper Adaptor
- (1) p/n 11080007001, 3/4" x 3/4" x 1/2" SWT Copper Tee

Plumbing Installation

Note: All plumbing and piping connections must comply with local plumbing codes.

⚠ WARNING ⚠

To avoid serious injury, it is recommended that an anti-scald mixing valve is installed on the hot water supply line into the home. Even though hot water tank temperatures could appear to be set at lower levels, high temperature water from the desuperheater could raise tank temperatures to unsafe levels.

TIP: Measure the distance above the floor or shelf that the water heater is setting on, to where the drain valve is located. This distance must be greater than one-half the width of the tee you're about to install, or you won't be able to thread the tee on to the water heater.

1. Disconnect electricity to water heater.
2. Turn off water supply to water heater.
3. Drain water heater. Open pressure relief valve.
4. Remove drain valve and fitting from water heater.
5. Thread the 3/4" MPT x 3-1/2" nipple into the water heater drain port. Use Teflon tape, or pipe dope on threads.
6. Thread the center port of the 3/4" brass tee to the other end of the nipple.
7. Thread one of the copper adaptors into the end of the tee closest to the heat pump.
8. Thread the drain valve into the other end of the nipple.
9. Above the water heater, cut the incoming cold water line. Remove a section of that line to enable the placement of the copper tee.
10. Insert the copper tee in the cold water line.
11. Thread the remaining two 1/2" SWT x 3/4" MPT copper adaptors into the 3/4" FPT fittings on the heat pump, marked HWG IN and HWG OUT.
12. Run interconnecting 1/2" copper pipe from the HOT WATER OUT on the heat pump, to the copper adaptor located on the tee at the bottom of the water heater.
13. Run interconnecting 1/2" copper pipe from the HOT WATER IN on the heat pump, to the copper tee in the cold water line.
14. Install an air vent fitting at the highest point of the line from step 13 (assuming it's the higher of the two lines from the heat pump to the water heater).
15. Shut off the valve installed in the desuperheater line close to the tee in the cold water line. Open the air vent and all shut off valves installed in the "hot water hot".
16. Turn the water supply to the water heater on. Fill water heater. Open highest hot water faucet to purge air from tank and piping.
17. Flush the interconnecting lines, and check for leaks. Make sure air vent is shutoff when water begins to drip steadily from the vent.
18. Loosen the screw on the end of the desuperheater pump to purge the air from the pump's rotor housing. A steady drip of water will indicate the air is removed. Tighten the screw and the pump can be connected to the contactor or terminal block.
19. Install 3/8" closed cell insulation on the lines connecting the heat pump to the water heater.
20. Reconnect electricity to water heater.
21. Install 3/8" closed cell insulation on the lines connecting the heat pump to the water heater.
22. Reconnect electricity to water heater.

Section 7: Desuperheater Installation

Figure 4: Water Heater Connection Kit Assembly for Bottom of Water Heater

Note: Drawing shown vertically for detail. Fitting installs horizontally into hot water tank.

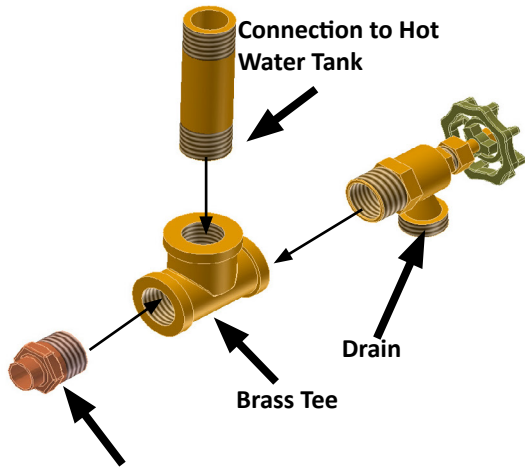

Adapter to Unit Water Line

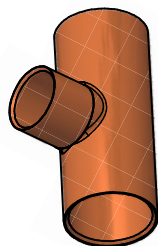

Copper Tee For Domestic Cold Water In Line



Typical Desuperheater Installation

The following drawings indicate typical GSHP connections. Please refer to product dimensional drawings for actual fitting and port locations

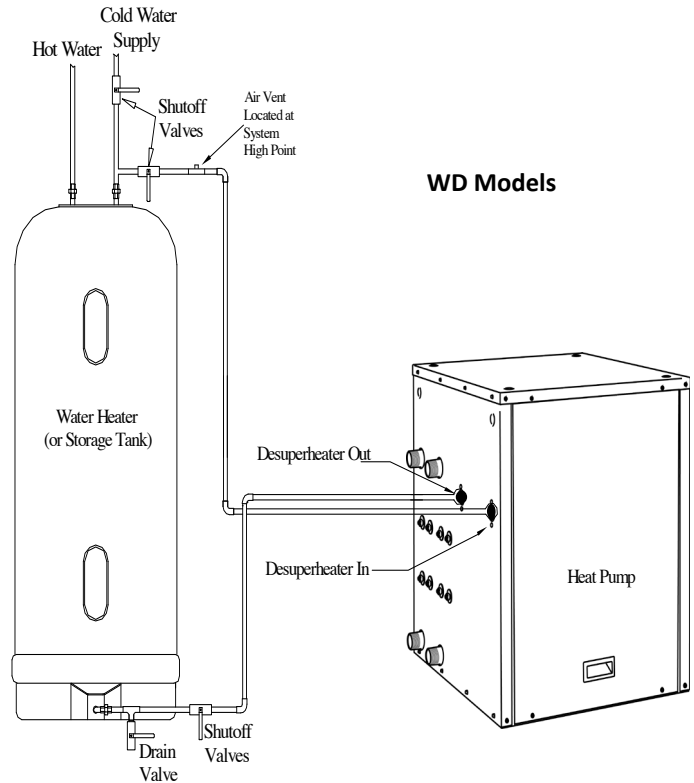

WD Models

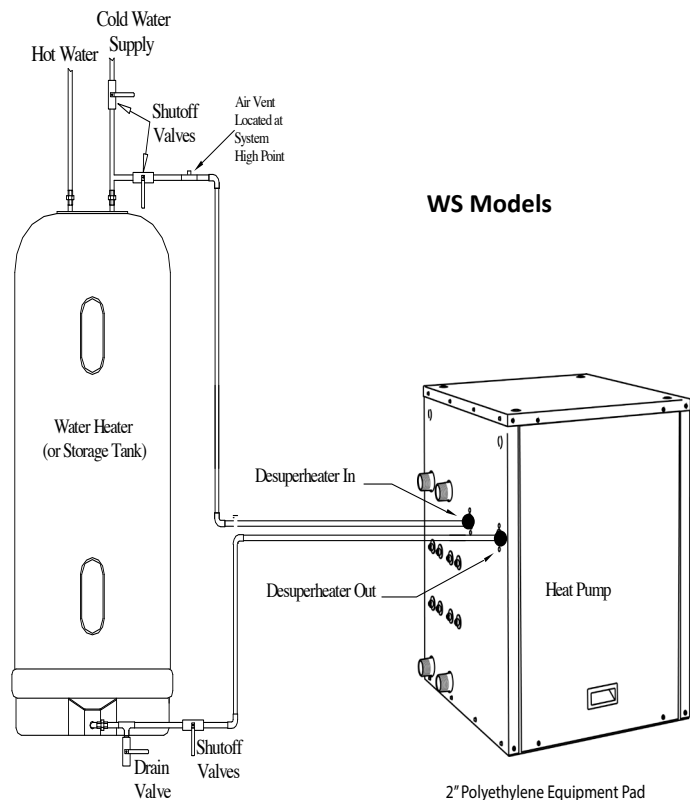

WS Models

2" Polyethylene Equipment Pad

Section 7: Desuperheater Installation

Desuperheater Installation with Preheat Tank

WD Models

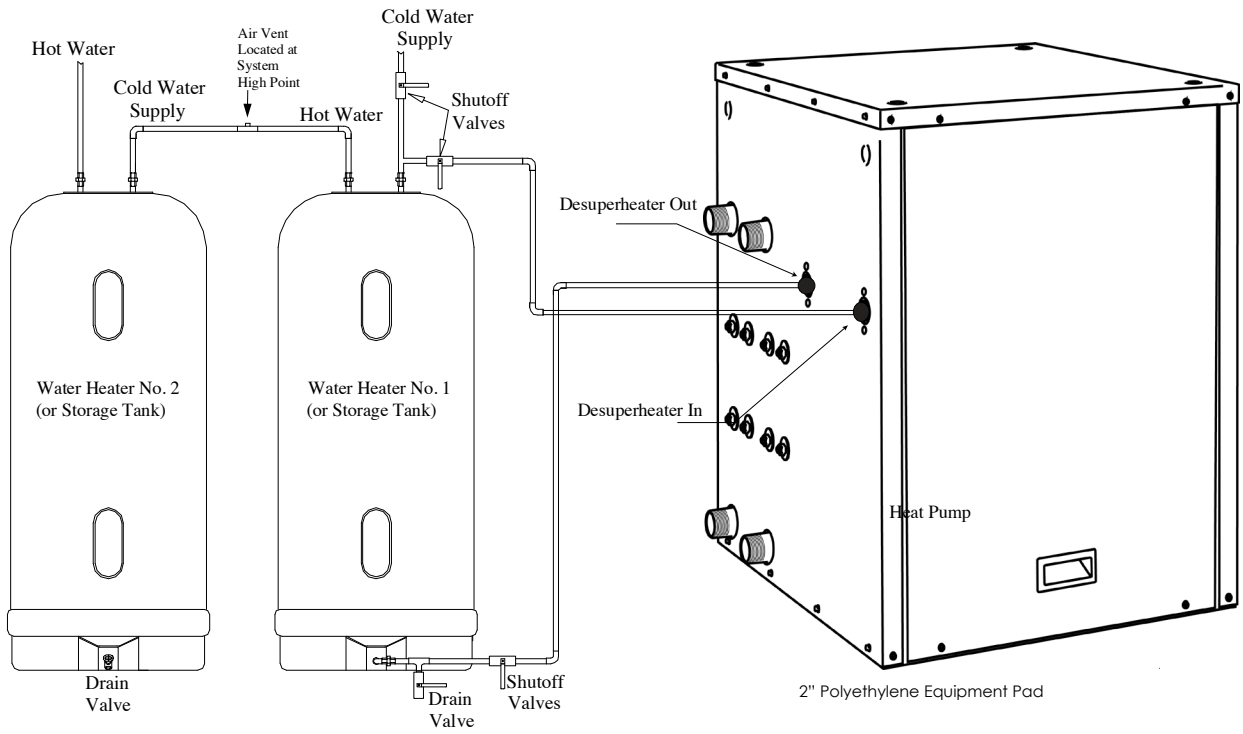

WS Models

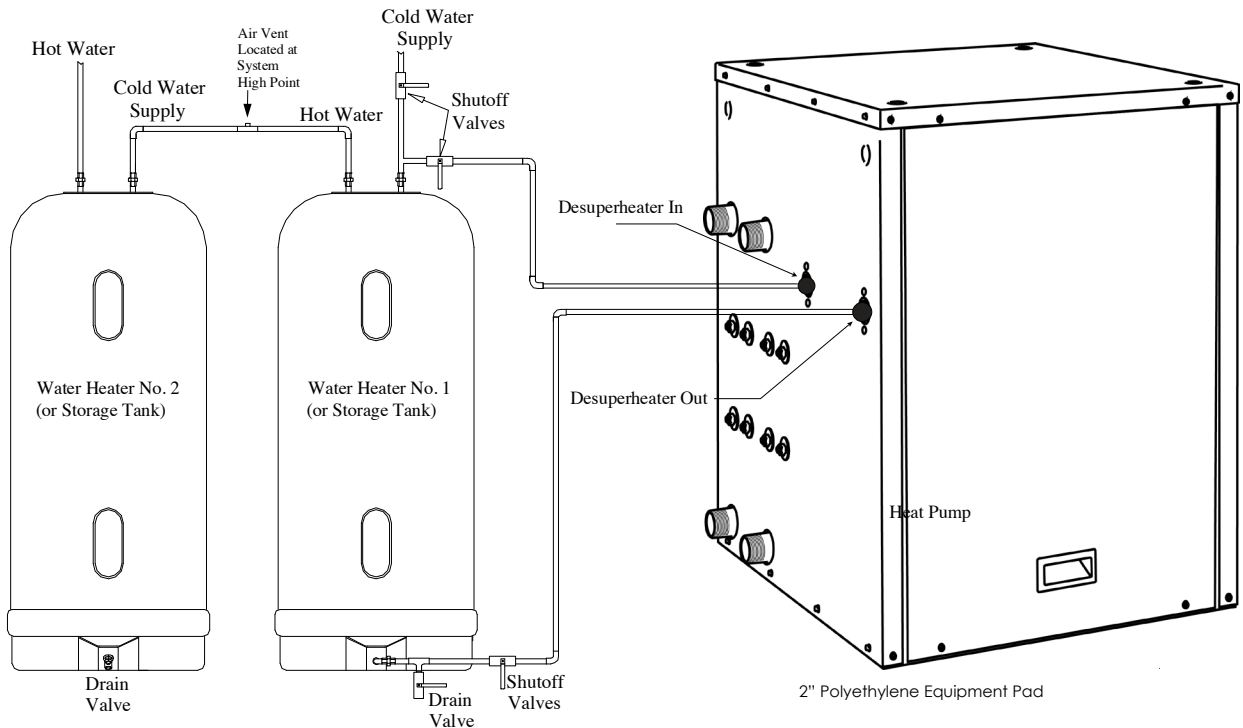

Section 8: Controls

Features

Enertech Global geothermal heat pump controls leverage a modular approach for controlling heat pump operation. The control system uses a combination of printed circuit boards, depending upon the features equipped in a particular unit. This approach simplifies installation and troubleshooting, and eliminates features that are not applicable for some units.

Figure 5: Lockout Board Layout

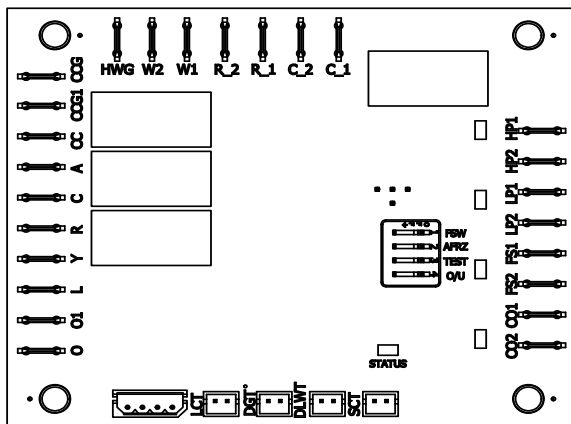

The Lockout Board controls the inputs to the unit as well as outputs for current mode, faults, and diagnostics. A status LED and different combination of four LEDs for each fault are provided for diagnostics. The Lockout Board Terminal (L) puts out the number of corresponding 24VAC pulses to indicate the Lockout condition on the Thermostat (if equipped and wired).

Startup/Random Start

The unit will not operate until all the inputs and safety controls are checked for normal conditions. A ten to twenty second random start delay is added at power up and whenever a Y1 call is received. This avoids multiple units from being energized at the same time after events such as power loss or brown outs.

Short Cycle Protection

A built-in five minute anti-short cycle (ASC) timer provides short cycle protection ensuring that the compressor isn't damaged due to rapid cycling.

Component Sequencing Delays

Components are sequenced and delayed for reduction in surge current, and to reduce startup noise of the system. The accessory terminal on the Lockout Board engages 10 seconds prior to the compressor. This provides increased time for items such as external pumps to provide adequate water flow prior to the system starting

Test Mode

The Lockout Board allows the technician to shorten timing delays for faster diagnostics by placing the DIP switch 'TEST' switch in the ON position (See 'Settings' section). It should be moved back to OFF for normal operation after testing. The status LED will not be illuminated during the TEST mode.

Water Solenoid Valve Connections

If equipped, the accessory terminal strip provides a field connection for a valve with an end switch, which is recommended (see wiring diagram). An accessory relay terminal, "A", can be used for solenoid valves without an end switch. This terminal is energized 10 seconds before the compressor contactor. A valve without an end switch could cause a water hammer effect and is not recommended.

Safety

The lockout board receives feedback signals for high pressure, low pressure, load heat exchanger temperature, source heat exchanger temperature, condensate overflow, and hot gas temperature faults. Upon a continuous 10-second measurement of all faults (except the high pressure) the compressor operation is suspended. The high pressure fault is tripped instantly. The different combination of LED(s) indicate each temporary fault. Once the unit is locked out (see fault retry below), the Lockout Board outputs a number of 24VAC pulses equal to the numbered fault code. In lock out the unit will not start until a soft or hard reset.

Low Pressure (LP)

If the low pressure switch is open continuously for 10 seconds, the compressor operation will be interrupted and the control will go into fault retry mode. At startup, the low pressure switch monitoring is suspended for 30 seconds to avoid nuisance faults.

Section 8: Controls

Note: Flow switches are not equipped with this unit. A jumper wire overrides this feature. A Flow switch kit is available to add on. Part#: 28K053-01NN

Flow Switch (FS)

Flow switches ensure the source and load water maintain the minimum required flow rate. This ensures that pumps are working and water connections remain intact. If the flow switch is open continuously for 10 seconds, the compressor operation will be interrupted with a FS fault. At startup, the flow switch monitoring is suspended for 30 seconds to avoid nuisance faults. The flow switches will also trip when the water begins to freeze, providing additional protection.

Note: Flow switches are not equipped with this unit. A jumper wire overrides this feature. A Flow switch kit is available to add on.

High Pressure (HP)

If the high pressure switch opens, the compressor operation will be interrupted, and the control will go into fault retry mode. There is no delay between the time the switch opens and the board entering into fault retry mode. There is also no delay of switch monitoring at startup. (If the high pressure switch is open before startup then the unit will not start upon receiving an Y1 call and will lock out instead.)

Load Heat Exchanger Freeze (LCT)

When in cooling mode, if the heat exchanger temperature is lower than 30°F for 10 continuous seconds, the compressor operation will be interrupted, and the control will go into fault retry mode. This sensor is located on the refrigerant line in between the heat exchanger and TXV (refrigerant inlet of heat exchanger in cooling mode).

Source Heat Exchanger Freeze (SCT)

When in heating mode, if the heat exchanger is lower than the setpoint for 10 continuous seconds, the compressor operation will be interrupted, and the control will go into fault retry mode. The setpoint is 12°F for closed loop (DIP switch AFRZ = ON) and 30°F for open loop (DIP switch AFRZ = OFF). At startup, the flow sensor is not monitored for 30 seconds to avoid nuisance faults. This sensor is located on the refrigerant line in between the source heat exchanger and TXV (refrigerant inlet of heat exchanger in heating mode).

Hot Discharge Gas Temperature (DGT)

When the hot discharge gas temperature is above 220°F for 30 continuous seconds, the compressor operation will be interrupted. The control will go into fault retry mode.

See Page 10: Section 3 For acceptable operating temp.

Desuperheater Leaving Water Temp (DLWT)

If equipped, controls monitor the desuperheater leaving water temperature (DLWT). The hot water generator pump is de-energized when the leaving water temperature (DLWT) is above 130°F or when the compressor discharge line (DGT) is cooler than leaving water temperature (DLWT).

Note: If not equipped with desuperheater, a 10k resistor pigtail is installed on the DLWT terminal.

Thermistor Sensors

The following table indicates the normal operating range of the temperature sensing thermistors. Readings outside this range are indicative of a bad sensor. The Lockout Board will display the associated fault.

| Temp. (°F) | Resistance (KΩ) | TEMP. (°F) | Resistance (KΩ) |
|------------|-----------------|------------|-----------------|
| 10 | 46.95 | 130 | 3.60 |
| 15 | 41.39 | 200 | 1.16 |
| 20 | 36.50 | 220 | 0.87 |
| 30 | 28.61 | 250 | 0.59 |
| 77 | 10.00 | 257 | 0.54 |

When diagnosing a possible bad sensor, the following table may be used to verify a valid temperature reading.

Section 8: Controls

Over/Under Voltage Protection

The lockout board protects the compressor from operating when an over/under voltage condition exists. The control monitors secondary voltage from the transformer (24VAC) to determine an over/under voltage condition is occurring on the primary side of the transformer. Under voltage (<18VAC) causes the compressor to disengage and restart when the voltage returns to >20VAC. Over voltage (>31VAC) causes the compressor to disengage and restart when the voltage returns to <29VAC.

When an O/U Voltage condition occurs, the board will initiate a fault, shut down the compressor, and start the five minute ASC period. All four fault LEDs will flash and the thermostat "Call For Service" indicator will be flashing 11 pulses. This feature is self- resetting and never retries or locks out. If voltage returns to normal range, normal operation will resume if/when the ASC period is over. When normal operation is restored the four fault LED's will stop flashing and the "Call For Service" indicator will turn off.

Fault Retry

All faults (except O/U Voltage and Bad Thermistor Sensors) are retried twice before finally locking the unit out (three faults total).

The fault retry feature is designed to prevent nuisance service calls. There is an anti-short cycle (ASC) period of 5 minutes between fault retries. On the third fault of the same sensor, within 30 minutes, the board will go into lockout mode and the "Call For Service" indicator on the thermostat will flash the number of pulses that correspond to the fault as shown in Fault Indication Table.

Intelligent Lockout Reset

If the thermostat is powered off (Y1 removed) for one minute then back on (soft reset), the board will reset and the last fault will be stored in memory for ease of troubleshooting. If main power is interrupted to the board, the fault memory will be cleared (hard reset).

Lockout with Emergency Heat

While in lockout mode, if the thermostat is calling for auxiliary heat (W1), emergency heat mode will energize. The second stage (W2) is energized two minutes after W1 is energized.

Hot Water Generator (HWG) Pump

Controls check for HWG temperature (DLWT) and compressor hot gas discharge line temperature (DGT). The hot water generator pump is de-energized when the leaving water temperature (DLWT) is above 130°F or when the compressor discharge line (DGT) is cooler than leaving water temperature (DLWT).

These conditions will disengage the HWG pump (via the HWG signal from the lockout board) and are considered normal operating sequences (they will not fault or lockout the compressor). However, if the DGT sensor detects temperatures >220°F, a fault will be thrown. Systems not equipped with HWG will have a 10k resistor pigtail in place of a thermistor in the DLWT socket (this allows monitoring DGT).

Control Board Switch Settings and Diagnostics

For fast and simple control board diagnosis, the lockout board includes five LEDs: Green, Orange, Red, Yellow, and a Green status indicator.

Section 8: Controls

| LOCKOUT BOARD LED IDENTIFICATION & L TERMINAL STATUS | | | | | | |
|--|----------|-----------|--------|-----------|--------------|-----------------------------------|
| CONDITION | GREEN HP | ORANGE LP | RED FS | YELLOW CO | GREEN STATUS | L TERMINAL- 24 VAC ^{8,9} |
| NORMAL MODE | | | | | FLASH | |
| TEST MODE ¹ | | | | | | |
| HP FAULT | FLASH | | | | FLASH | |
| HP LOCKOUT | ON | | | | FLASH | FLASH-2 PULSES |
| LP FAULT | | FLASH | | | FLASH | |
| LP LOCKOUT | | ON | | | FLASH | FLASH-4 PULSES |
| WF FAULT (FS) ³ | | | FLASH | | FLASH | |
| WF LOCKOUT (FS) ³ | | | ON | | FLASH | FLASH- 6 PULSES |
| LOAD/ AIR COIL FRZ FAULT (LCT) ^{2,3} | | FLASH | FLASH | | FLASH | |
| LOAD/ AIR COIL FRZ LOCKOUT (LCT) ^{2,3} | | ON | ON | | FLASH | FLASH-8 PULSES |
| SOURCE COIL FRZ FAULT (SCT) | | | FLASH | FLASH | | |
| SOURCE COIL FRZ LOCKOUT (SCT) | | | ON | ON | | FLASH-19 PULSES |
| CO FAULT ³ | | | | FLASH | FLASH | |
| CO LOCKOUT ³ | | | | ON | FLASH | FLASH-10 PULSES |
| O/ U VOLTAGE | FLASH | FLASH | FLASH | FLASH | FLASH | FLASH-11 PULSES |
| LCT SENSOR LOCKOUT/FAULTY ⁴ | FLASH | | | ON | FLASH | FLASH-12 PULSES |
| DGT SENSOR FAULTY ^{3,4} | | FLASH | | ON | FLASH | FLASH-13 PULSES |
| DLWT SENSOR FAULTY ^{4,7} | | | FLASH | ON | FLASH | FLASH-14 PULSES |
| SCT SENSOR LOCKOUT/ FAULTY ⁴ | | ON | | FLASH | FLASH | FLASH-15 PULSES |
| LCT & SCT SWAPPED ⁵ | ON | | | ON | | FLASH-16 PULSES |
| DGT > 220°F FAULT ^{3,6} | FLASH | | FLASH | ON | FLASH | |
| DGT > 220°F LOCKOUT ^{3,6} | ON | | ON | ON | FLASH | FLASH-18 PULSES |

| LOCKOUT BOARD DIP SWITCHES | | |
|----------------------------|---|---|
| DIP SWITCH | OFF | ON |
| FSW ¹¹ | LCT & SCT SENSORS AND 'FS' TERMINALS MONITORED FOR FLOW | FS' TERMINALS MONITORED FOR FLOW |
| AFRZ | OPEN LOOP MODE- 30°F SETTING FOR SCT | CLOSED LOOP MODE- 12°F SETTING FOR SCT |
| TEST | OPERATES IN NORMAL MODE WITH STANDARD DELAYS | OPERATES IN TEST MODE WITH DELAYS SPED UP |
| O/ U | FEATURE IS INACTIVE | FEATURE IS ACTIVE |

NOTES:

1. WHEN TEST MODE DIP SWITCH IS 'ON', GREEN STATUS LED WILL BE OFF.
2. THE LOAD/ AIR COIL FREEZE PROTECTION SENSOR IS LOCATED BETWEEN THE TXV AND LOAD COAX IN WATER-TO-WATER UNITS, AND BETWEEN THE TXV AND AIR COIL IN WATER-TO-AIR UNITS.
3. NOT ALL MODELS HAVE THIS FEATURE.
4. THIS FAULT INDICATES A BAD SENSOR (OPEN, SHORTED, DISCONNECTED, OR INVALID VALUE).
5. THE CHECK TO DETERMINE IF THE LCT AND SCT SENSORS ARE SWAPPED, OCCURS IN TEST MODE ONLY, 120 SECONDS AFTER THE 'CC' TERMINAL IS ENERGIZED.
6. THIS FAULT/ LOCKOUT INDICATES THAT THE DISCHARGE GAS TEMPERATURE IS ABOVE 220°F.
7. UNITS WITHOUT DESUPERHEATER (HWG) HAVE A 10K RESISTOR IN POSITION T3 (DLWT).
8. CONNECT A MULTIMETER ACROSS THE 'L' AND 'C' TERMINALS TO CHECK FOR 24 VAC LOCKOUT SIGNAL. THERMOSTAT TURNS ON/FLASHES 'CALL FOR SERVICE' INDICATION.
9. THE 'L' TERMINAL CONTROLS A FAULT LED AT THE THERMOSTAT OR DRIVES AN AUXILLIARY FAULT RELAY.
10. UNITS THAT DO NOT CONTAIN A FLOW SWITCH, WILL CONTAIN A JUMPER BETWEEN THE 'FS1' AND 'FS2' TERMINALS.

Section 8: Controls

Lockout Board DIP Switches

The lockout board has four DIP switches for field selection of features shown below.

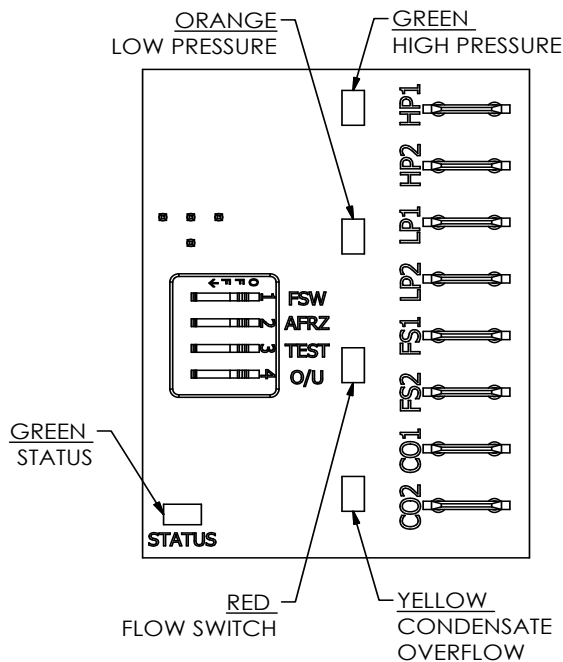

Load/Source Temperature Sensing (FSW)

When the DIP switch FSW is OFF, the board operates in dual protection mode. The load and source heat exchanger temperatures are monitored (with LCT and SCT thermistors) as well as field installed flow switches. When the DIP switch FSW is ON, the board operates in thermistor override mode and monitors only the flow switch (LCT and SCT are ignored).

Note: No setting allows ignoring of the flow switch. A factory installed jumper wire disables flow monitoring. Optional flow switch kits are available. Please remember, the unit size and heat exchanger determines which kit is used. Part#: 28K053-01NN, 28K053-02NN, 28K053-03NN, 28K053-04NN.

Anti-Freeze (AFRZ)

When DIP switch AFRZ is OFF, the Lockout Board operates in open loop mode. The setpoint for the source heat exchanger freeze sensor is set to 30°F. When DIP switch AFRZ is ON, the board operates in the closed loop mode. The setpoint for the source heat exchanger freeze sensor is 12°F in closed loop mode.

⚠ CAUTION ⚠

If insufficient antifreeze used in either source or load sides, a flow switch must be field installed. Field Kit 28K053-01NN is available

Test Mode (TEST)

When DIP switch TEST is OFF, the Lockout board operates in the normal mode. When DIP switch TEST is ON, the board operates in test mode, which speeds up all delays for easier troubleshooting. While in the test mode the LCT & SCT sensors will be checked for the proper location based on temperature. Sensors are swapped if $LCT > SCT$ in cooling or $LCT < SCT$ in heating. This fault will only show up in the test mode. When service is complete, the DIP switch TEST must be returned to the OFF position in order to make sure the unit operates with normal sequencing delays. While the unit is in Test Mode, the status light (bottom green) will remain off. The Lockout Board will revert back to normal mode after one (1) hour (green status light blinks), if DIP switch TEST is not moved to OFF position.

Over/Under Voltage Disable (O/U)

When the DIP switch O/U is ON, the over/under voltage feature is active. When the DIP switch O/U is OFF, the over/under voltage feature is disabled. On rare occasions, variations in voltage will be outside the range of the over/under voltage feature, which may require to disabling of the feature. However, disabling the feature could cause the unit to run under adverse conditions, and therefore should not be turned off without contacting Enertech technical services. An over/under voltage condition could cause premature component failure or damage to the unit controls. Any condition causing this fault must be thoroughly investigated before taking any action regarding disabling O/U feature. Likely causes of an over/under voltage condition include power company transformer selection, insufficient entrance wire sizing, defective breaker panel, incorrect 24VAC transformer tap (unit control box), or other power-related issues like brownouts.

⚠ CAUTION ⚠

Brazed plate heat exchangers are not designed to be used for open loop/well water applications or any applications when antifreeze is not used. A unit with a coaxial heat exchanger should be used for open loop applications. If using a brazed plate heat exchanger on an open application, a secondary heat exchanger must be installed with antifreeze in the piping between the unit and the secondary heat exchanger.

Section 8: Controls

Sequence of Operation

The description below is based on Water-to-Water Units, Single and Double Compressor.

Timings assume the ASC timer is expired. If the ASC timer is not expired the accessory, compressor, and loop pump operation do not start until the ASC timer is expired.

Heating 1st Stage, (Y1) WS and WD models

The Accessory (A) terminal output is energized after the random start timer (10s-20s) expires. Next, after another 10s delay, the compressor first stage and the loop pump(s) are energized.

Heating 2nd Stage, (Y1, Y2) WD models only

After the adjustable time delay relay expires and a Y2 call is received, the second compressor is energized.

Cooling Operation

The reversing valve is energized for cooling operation. Terminal "O" from the thermostat is connected to the reversing valve solenoid.

Cooling 1st stage (Y1, O) WS and WD models

The Accessory (A) terminal output is energized after the random start timer (10s-20s) expires then the first stage compressor and the loop pump(s) are energized 10 seconds after A.

Cooling 2nd Stage (Y1, Y2, O) WD models only

After the adjustable time delay relay expires and a Y2 call is received, the second compressor is energized.

Section 9: Wiring Diagrams

WATER-TO-WATER UNIT, SINGLE STAGE, SINGLE PHASE, 208/230V, 60HZ, RESIDENTIAL *WS SERIES

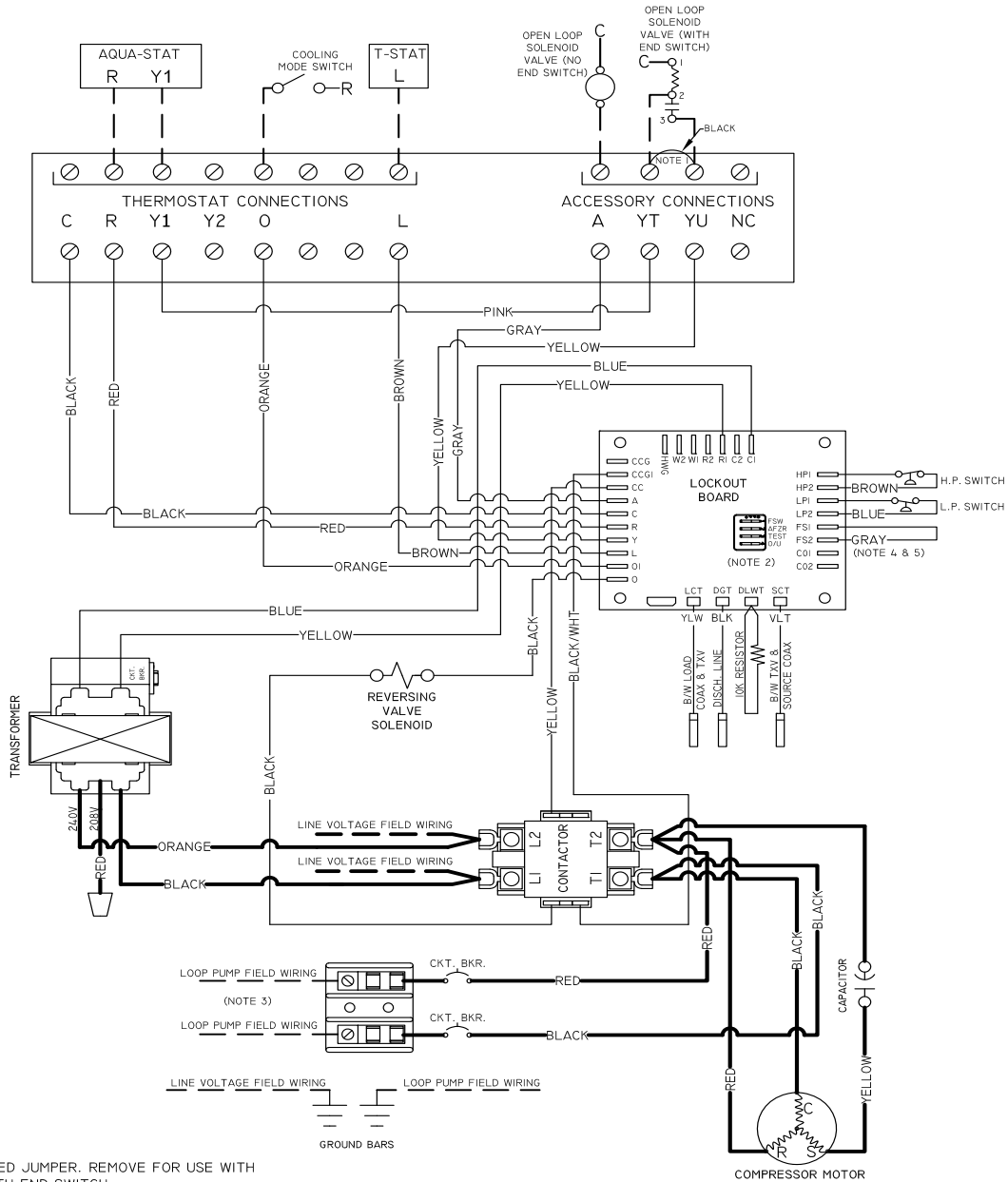

NOTES:

- FACTORY INSTALLED JUMPER. REMOVE FOR USE WITH SOLENOID VALVE WITH END SWITCH.
- SEE LOCKOUT BOARD LABEL FOR DIP SWITCH SELECTION/ DESCRIPTION.
- LOAD SIDE PUMPING IS HANDLED VIA CONNECTION TO THE LOOP PUMP TERMINAL BLOCK (I.E. THE LOOP PUMPS AND LOAD PUMPS CAN BE POWERED FROM THE UNIT AS LONG AS NO MORE THAN THREE UP26-116 PUMPS ARE CONNECTED).
- FOR UNITS WITHOUT FLOW SWITCHES (COPPER-BPHE CONFIGURATIONS), AN OPTIONAL EXTERNAL FLOW SWITCH KIT IS AVAILABLE. THE GRAY JUMPER WIRE, THAT GOES BETWEEN FS1 AND FS2, WILL NEED TO BE REMOVED AND THE SWITCHES SHOULD BE WIRED IN SERIES TO THE LOCKOUT BOARD, AS SHOWN IN DIAGRAM #1. REFERENCE THE FLOW SWITCH KIT INSTRUCTIONS FOR ADDITIONAL DETAILS.
- UNITS WITH A CUPRO-NICKEL COIL, WILL HAVE A FLOW SWITCH INSTALLED ON THE SOURCE SIDE THAT IS WIRED TO THE FS1 AND FS2 TERMINALS ON THE LOCKOUT BOARD, AS SHOWN IN DIAGRAM #2.

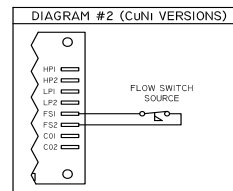
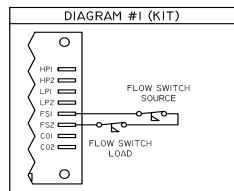

Section 9: Wiring Diagrams

WATER-TO-WATER UNIT, SINGLE STAGE, SINGLE PHASE, 208/230V, 60HZ, DSH, RESIDENTIAL & COMMERCIAL *WS SERIES

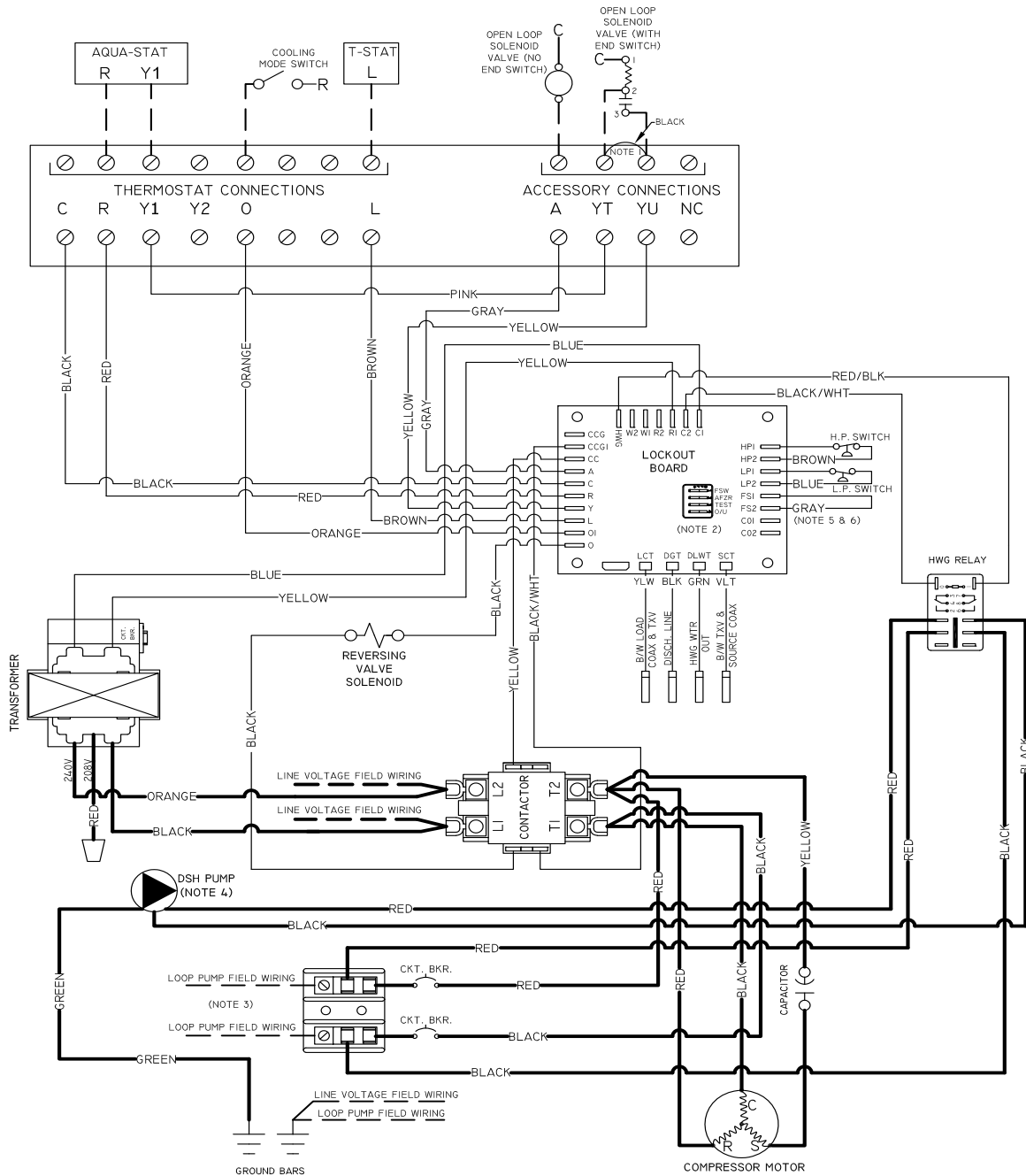

NOTES:

1. FACTORY INSTALLED JUMPER. REMOVE FOR USE WITH SOLENOID VALVE WITH END SWITCH.
2. SEE LOCKOUT BOARD LABEL FOR DIP SWITCH SELECTION/ DESCRIPTION.
3. LOAD SIDE PUMPING IS HANDLED VIA CONNECTION TO THE LOOP PUMP TERMINAL BLOCK (I.E. THE LOOP PUMPS AND LOAD PUMPS CAN BE POWERED FROM THE UNIT AS LONG AS NO MORE THAN THREE UP26-116 PUMPS ARE CONNECTED).
4. DESUPERHEATER PUMP POWER WIRES ARE NOT CONNECTED AT THE FACTORY. DO NOT CONNECT THE WIRES UNTIL THE PIPING IS COMPLETED AND PURGED OF AIR. RUNNING THE PUMP WITHOUT WATER WILL DAMAGE THE PUMP.
5. FOR UNITS WITHOUT FLOW SWITCHES (COPPER-BPHE CONFIGURATIONS), AN OPTIONAL EXTERNAL FLOW SWITCH KIT IS AVAILABLE. THE GRAY JUMPER WIRE, THAT GOES BETWEEN FS1 AND FS2, WILL NEED TO BE REMOVED AND THE SWITCHES SHOULD BE WIRED IN SERIES TO THE LOCKOUT BOARD, AS SHOWN IN **DIAGRAM #1**. REFERENCE THE FLOW SWITCH KIT INSTRUCTIONS FOR ADDITIONAL DETAILS.
6. UNITS WITH A CUPRO-NICKEL COIL, WILL HAVE A FLOW SWITCH INSTALLED ON THE SOURCE SIDE THAT IS WIRED TO THE FS1 AND FS2 TERMINALS ON THE LOCKOUT BOARD, AS SHOWN IN **DIAGRAM #2**.

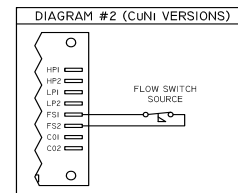
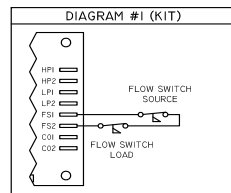

Section 9: Wiring Diagrams

WATER-TO-WATER UNIT, SINGLE STAGE, SINGLE PHASE, 208/230V, 60HZ, COMMERCIAL *WS SERIES

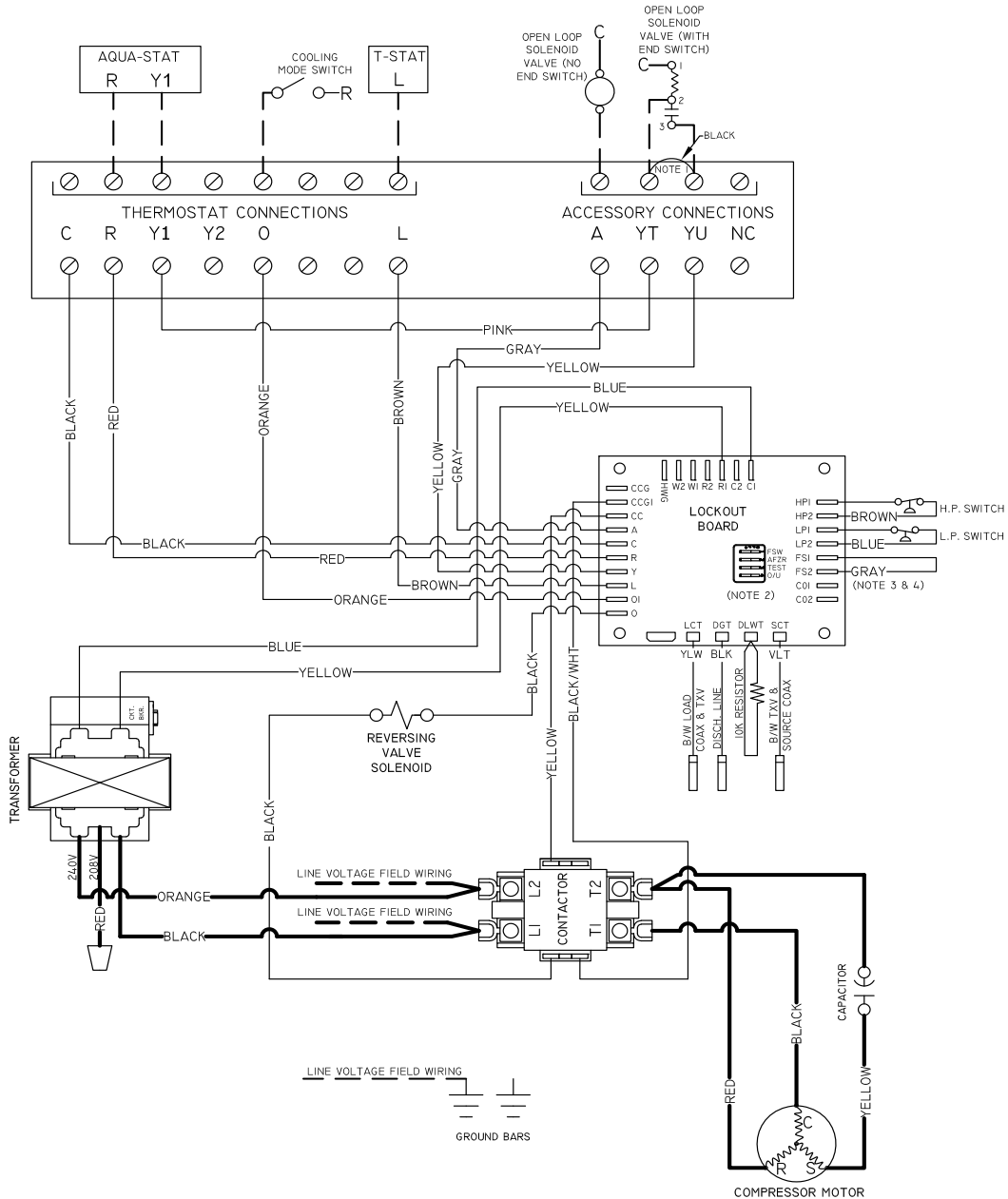

NOTES:

1. FACTORY INSTALLED JUMPER. REMOVE FOR USE WITH SOLENOID VALVE WITH END SWITCH.
2. SEE LOCKOUT BOARD LABEL FOR DIP SWITCH SELECTION/ DESCRIPTION.
3. FOR UNITS WITHOUT FLOW SWITCHES (COPPER-BPHE CONFIGURATIONS), AN OPTIONAL EXTERNAL FLOW SWITCH KIT IS AVAILABLE. THE GRAY JUMPER WIRE, THAT GOES BETWEEN FSI AND FS2, WILL NEED TO BE REMOVED AND THE SWITCHES SHOULD BE WIRED IN SERIES TO THE LOCKOUT BOARD, AS SHOWN IN **DIAGRAM #1**. REFERENCE THE FLOW SWITCH KIT INSTRUCTIONS FOR ADDITIONAL DETAILS.
4. UNITS WITH A CUPRO-NICKEL COIL, WILL HAVE A FLOW SWITCH INSTALLED ON THE SOURCE SIDE THAT IS WIRED TO THE FSI AND FS2 TERMINALS ON THE LOCKOUT BOARD, AS SHOWN IN **DIAGRAM #2**.

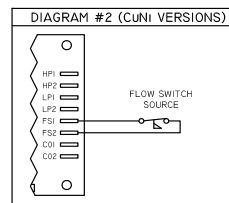
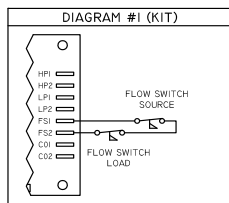

Section 9: Wiring Diagrams

WATER-TO-WATER UNIT, SINGLE STAGE, THREE PHASE, 208/230V, 60HZ, COMMERCIAL *WS SERIES

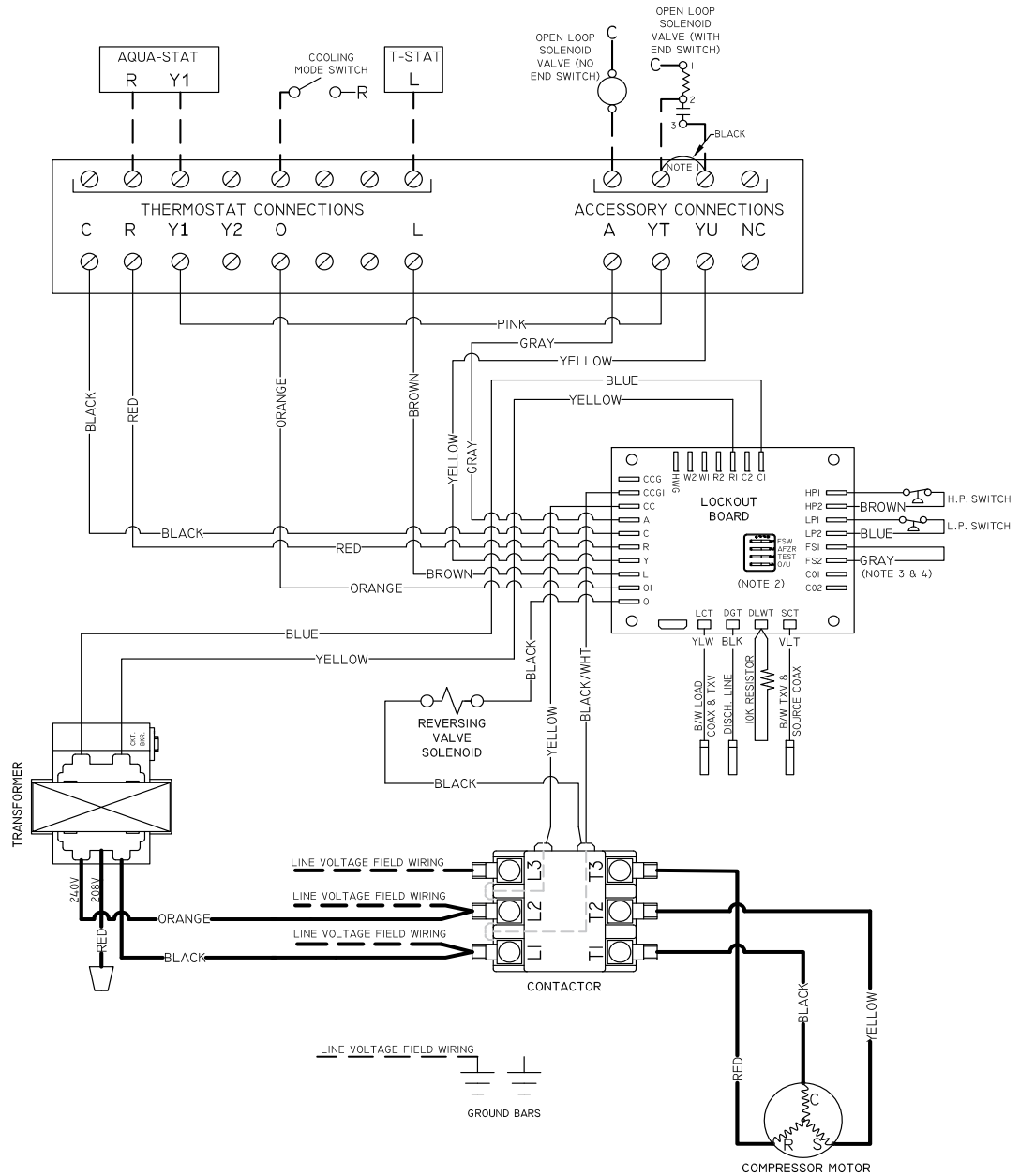

NOTES:

1. FACTORY INSTALLED JUMPER. REMOVE FOR USE WITH SOLENOID VALVE WITH END SWITCH.
2. SEE LOCKOUT BOARD LABEL FOR DIP SWITCH SELECTION/ DESCRIPTION.
3. FOR UNITS WITHOUT FLOW SWITCHES (COPPER-BPHE CONFIGURATIONS), AN OPTIONAL EXTERNAL FLOW SWITCH KIT IS AVAILABLE. THE GRAY JUMPER WIRE, THAT GOES BETWEEN FSI AND FS2, WILL NEED TO BE REMOVED AND THE SWITCHES SHOULD BE WIRED IN SERIES TO THE LOCKOUT BOARD, AS SHOWN IN **DIAGRAM #1**. REFERENCE THE FLOW SWITCH KIT INSTRUCTIONS FOR ADDITIONAL DETAILS.
4. UNITS WITH A CUPRO-NICKEL COIL, WILL HAVE A FLOW SWITCH INSTALLED ON THE SOURCE SIDE THAT IS WIRED TO THE FSI AND FS2 TERMINALS ON THE LOCKOUT BOARD, AS SHOWN IN **DIAGRAM #2**.

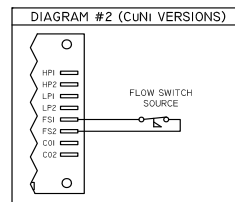
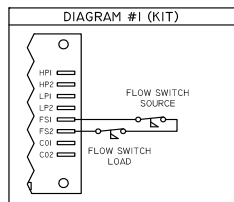

Section 9: Wiring Diagrams

WATER-TO-WATER UNIT, SINGLE STAGE, THREE PHASE, 208/230V, 60HZ, DSH, COMMERCIAL *WS SERIES

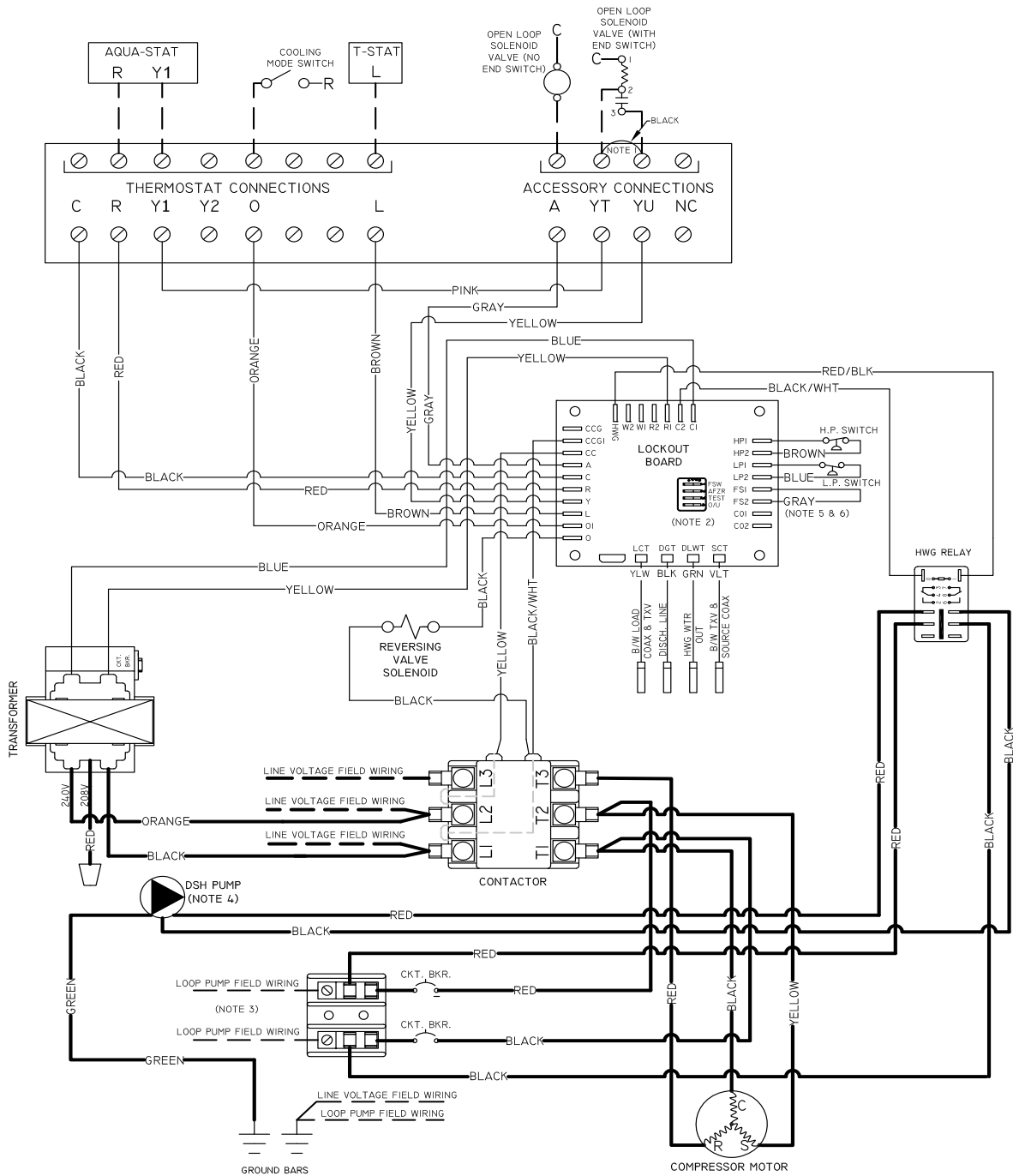

NOTES:

1. FACTORY INSTALLED JUMPER. REMOVE FOR USE WITH SOLENOID VALVE WITH END SWITCH.
2. SEE LOCKOUT BOARD LABEL FOR DIP SWITCH SELECTION/ DESCRIPTION.
3. LOAD SIDE PUMPING IS HANDLED VIA CONNECTION TO THE LOOP PUMP TERMINAL BLOCK (I.E. THE LOOP PUMPS AND LOAD PUMPS CAN BE POWERED FROM THE UNIT AS LONG AS NO MORE THAN THREE UP26-116 PUMPS ARE CONNECTED).
4. DESUPERHEATER PUMP POWER WIRES ARE NOT CONNECTED AT THE FACTORY. DO NOT CONNECT THE WIRES UNTIL THE PIPING IS COMPLETED AND PURGED OF AIR. RUNNING THE PUMP WITHOUT WATER WILL DAMAGE THE PUMP.
5. FOR UNITS WITHOUT FLOW SWITCHES (COPPER-BPHE CONFIGURATIONS), AN OPTIONAL EXTERNAL FLOW SWITCH KIT IS AVAILABLE. THE GRAY JUMPER WIRE, THAT GOES BETWEEN FSI AND FS2, WILL NEED TO BE REMOVED AND THE SWITCHES SHOULD BE WIRED IN SERIES TO THE LOCKOUT BOARD, AS SHOWN IN **DIAGRAM #1**. REFERENCE THE FLOW SWITCH KIT INSTRUCTIONS FOR ADDITIONAL DETAILS.
6. UNITS WITH A CUPRO-NICKEL COIL, WILL HAVE A FLOW SWITCH INSTALLED ON THE SOURCE SIDE THAT IS WIRED TO THE FSI AND FS2 TERMINALS ON THE LOCKOUT BOARD, AS SHOWN IN **DIAGRAM #2**.

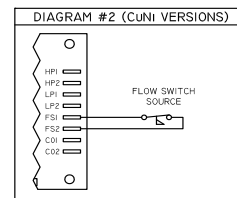
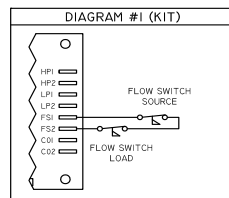

Section 9: Wiring Diagrams

WATER-TO-WATER UNIT, SINGLE STAGE, THREE PHASE, 460V, 60HZ, COMMERCIAL *WS SERIES

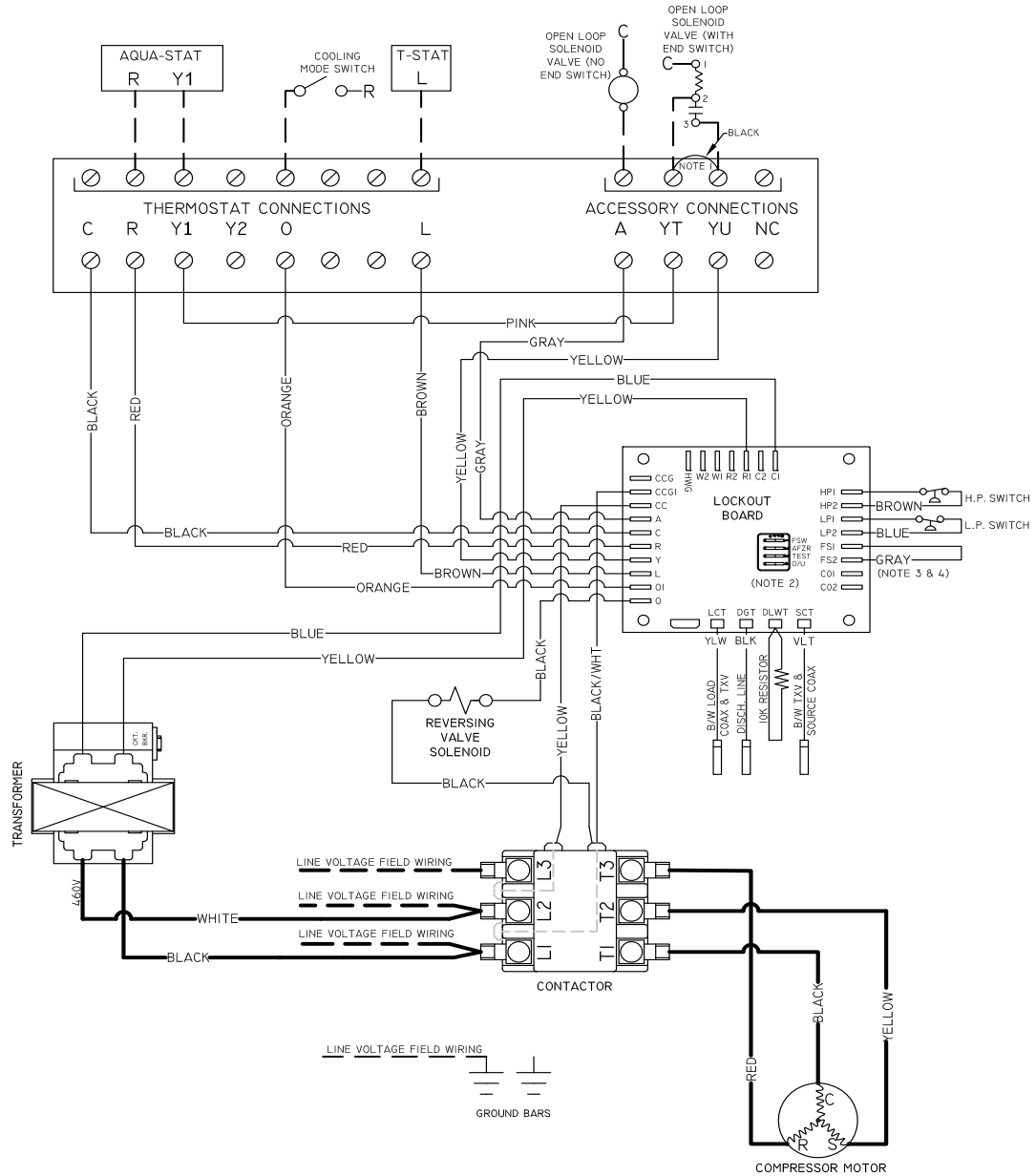

NOTES:

1. FACTORY INSTALLED JUMPER. REMOVE FOR USE WITH SOLENOID VALVE WITH END SWITCH.
2. SEE LOCKOUT BOARD LABEL FOR DIP SWITCH SELECTION/ DESCRIPTION.
3. FOR UNITS WITHOUT FLOW SWITCHES (COPPER-BPHE CONFIGURATIONS), AN OPTIONAL EXTERNAL FLOW SWITCH KIT IS AVAILABLE. THE GRAY JUMPER WIRE, THAT GOES BETWEEN FSI AND FS2, WILL NEED TO BE REMOVED AND THE SWITCHES SHOULD BE WIRED IN SERIES TO THE LOCKOUT BOARD, AS SHOWN IN **DIAGRAM #1**. REFERENCE THE FLOW SWITCH KIT INSTRUCTIONS FOR ADDITIONAL DETAILS.
4. UNITS WITH A CUPRO-NICKEL COIL, WILL HAVE A FLOW SWITCH INSTALLED ON THE SOURCE SIDE THAT IS WIRED TO THE FSI AND FS2 TERMINALS ON THE LOCKOUT BOARD, AS SHOWN IN **DIAGRAM #2**.

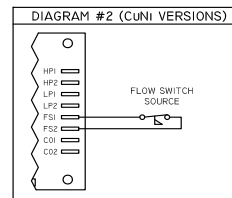
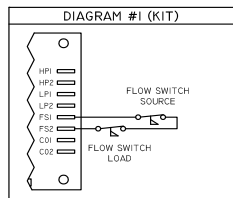

Section 9: Wiring Diagrams

WATER-TO-WATER UNIT, SINGLE STAGE, THREE PHASE, 460V, 60HZ, DSH, COMMERCIAL*WS SERIES

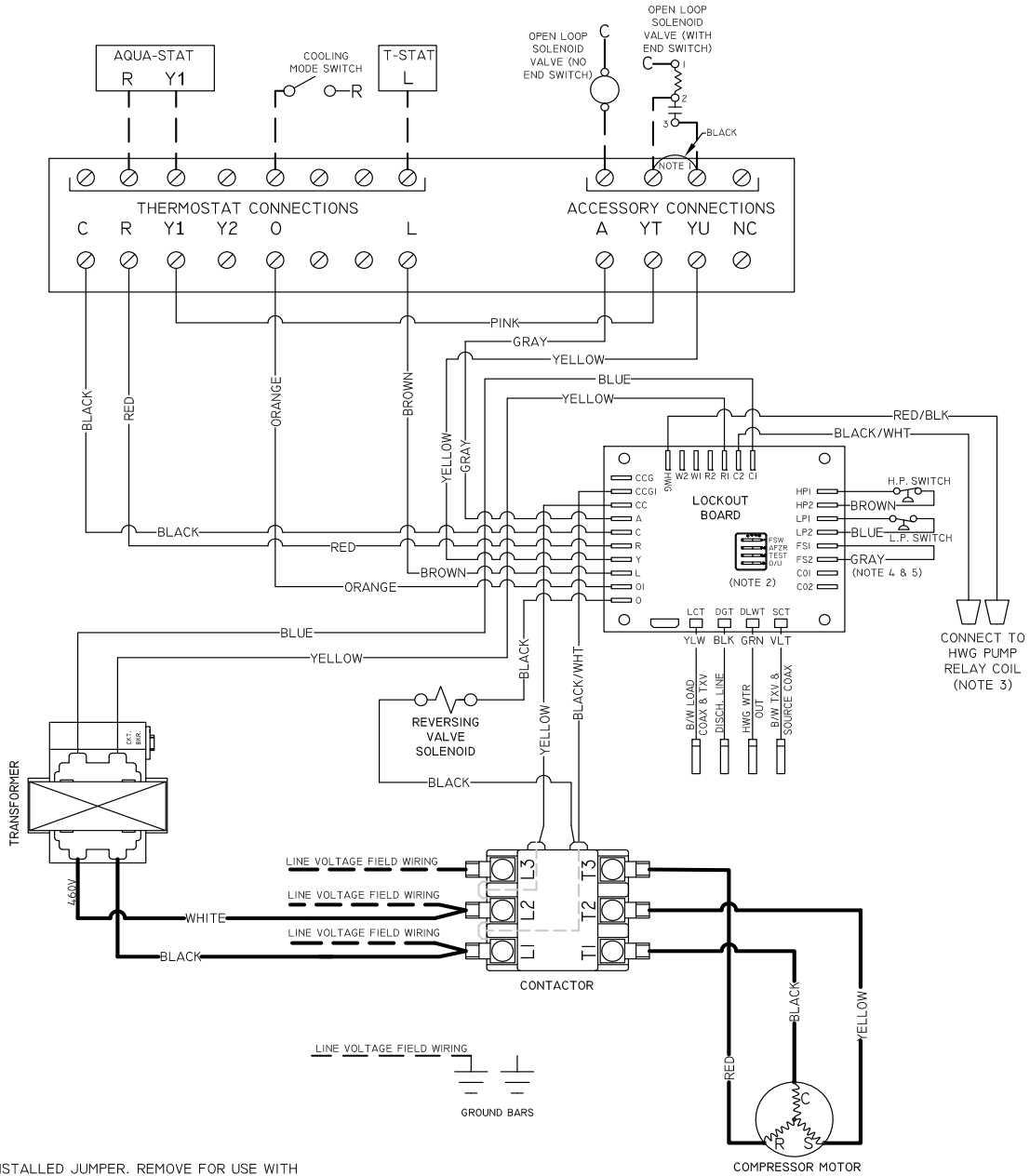

NOTES:

1. FACTORY INSTALLED JUMPER. REMOVE FOR USE WITH SOLENOID VALVE WITH END SWITCH.
2. SEE LOCKOUT BOARD LABEL FOR DIP SWITCH SELECTION/ DESCRIPTION.
3. CONNECT WIRES TO THE HWG PUMP RELAY COIL. RELAY IS TO BE PROVIDED BY THE INSTALLER AND IS A N.C. RELAY THAT WILL INTERRUPT POWER TO THE PUMP WHEN CONDITIONS ARE INAPPROPRIATE FOR WATER HEATING. IF WIRES ARE NOT CONNECTED TO RELAY, SCALDING CAN OCCUR.
4. FOR UNITS WITHOUT FLOW SWITCHES (COPPER-BPHE CONFIGURATIONS), AN OPTIONAL EXTERNAL FLOW SWITCH KIT IS AVAILABLE. THE GRAY JUMPER WIRE, THAT GOES BETWEEN FSI AND FS2, WILL NEED TO BE REMOVED AND THE SWITCHES SHOULD BE WIRED IN SERIES TO THE LOCKOUT BOARD, AS SHOWN IN **DIAGRAM #1**. REFERENCE THE FLOW SWITCH KIT INSTRUCTIONS FOR ADDITIONAL DETAILS.
5. UNITS WITH A CUPRO-NICKEL COIL, WILL HAVE A FLOW SWITCH INSTALLED ON THE SOURCE SIDE THAT IS WIRED TO THE FSI AND FS2 TERMINALS ON THE LOCKOUT BOARD, AS SHOWN IN **DIAGRAM #2**.

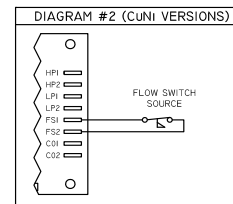
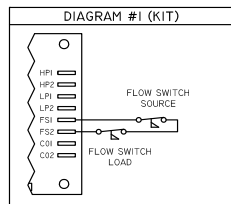

Section 9: Wiring Diagrams

WATER-TO-WATER UNIT, TWO STAGE, SINGLE PHASE, 208/230V, 60HZ, RESIDENTIAL & COMMERCIAL *WDI20

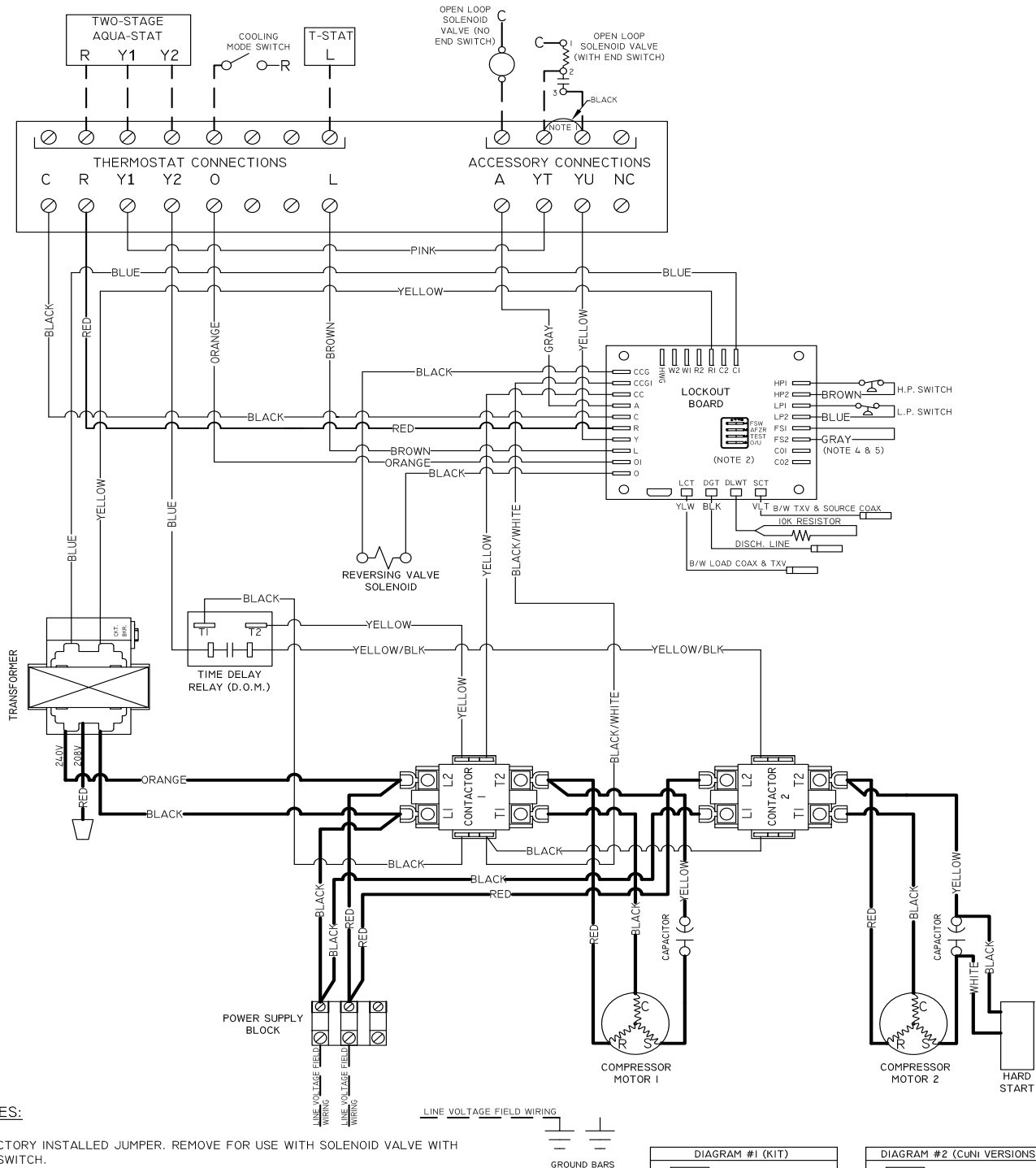

NOTES:

1. FACTORY INSTALLED JUMPER. REMOVE FOR USE WITH SOLENOID VALVE WITH END SWITCH.
2. SEE LOCKOUT BOARD LABEL FOR DIP SWITCH SELECTION/ DESCRIPTION.
3. UNITS 10 TON AND LARGER ARE CONSIDERED 'COMMERCIAL' UNITS AND ALL PIPING IS HANDLED FROM A SEPARATE ELECTRICAL CIRCUIT OUTSIDE OF THE UNIT.
4. FOR UNITS WITHOUT FLOW SWITCHES (COPPER-BPHE CONFIGURATIONS), AN OPTIONAL EXTERNAL FLOW SWITCH KIT IS AVAILABLE. THE GRAY JUMPER WIRE, THAT GOES BETWEEN FS1 AND FS2, WILL NEED TO BE REMOVED AND THE SWITCHES SHOULD BE WIRED IN SERIES TO THE LOCKOUT BOARD, AS SHOWN IN **DIAGRAM #1**. REFERENCE THE FLOW SWITCH KIT INSTRUCTIONS FOR ADDITIONAL DETAILS.
5. UNITS WITH A CUPRO-NICKEL COIL, WILL HAVE A FLOW SWITCH INSTALLED ON THE SOURCE SIDE THAT IS WIRED TO THE FS1 AND FS2 TERMINALS ON THE LOCKOUT BOARD, AS SHOWN IN **DIAGRAM #2**.

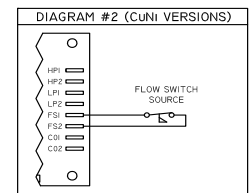
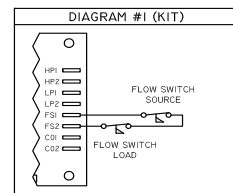

Section 9: Wiring Diagrams

WATER-TO-WATER UNIT, TWO STAGE, SINGLE PHASE, 208/230V, 60HZ, DSH, RESIDENTIAL & COMMERCIAL *WDI20

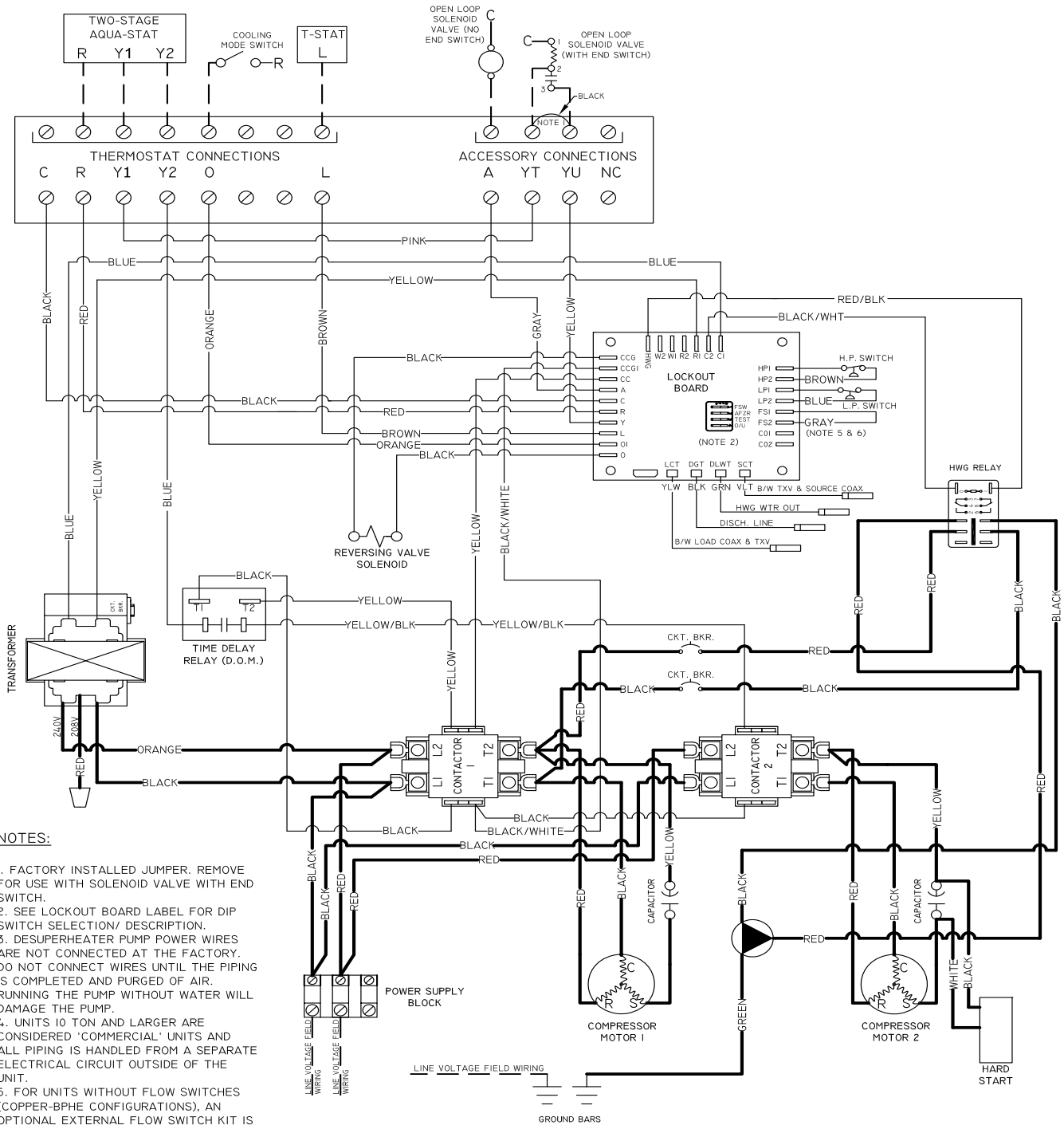

NOTES:

1. FACTORY INSTALLED JUMPER. REMOVE FOR USE WITH SOLENOID VALVE WITH END SWITCH.
2. SEE LOCKOUT BOARD LABEL FOR DIP SWITCH SELECTION/ DESCRIPTION.
3. DESUPERHEATER PUMP POWER WIRES ARE NOT CONNECTED AT THE FACTORY. DO NOT CONNECT WIRES UNTIL THE PIPING IS COMPLETED AND PURGED OF AIR. RUNNING THE PUMP WITHOUT WATER WILL DAMAGE THE PUMP.
4. UNITS 10 TON AND LARGER ARE CONSIDERED 'COMMERCIAL' UNITS AND ALL PIPING IS HANDLED FROM A SEPARATE ELECTRICAL CIRCUIT OUTSIDE OF THE UNIT.
5. FOR UNITS WITHOUT FLOW SWITCHES (COPPER-BPHE CONFIGURATIONS), AN OPTIONAL EXTERNAL FLOW SWITCH KIT IS AVAILABLE. THE GRAY JUMPER WIRE, THAT GOES BETWEEN FSI AND FS2, WILL NEED TO BE REMOVED AND THE SWITCHES SHOULD BE WIRED IN SERIES TO THE LOCKOUT BOARD, AS SHOWN IN DIAGRAM #1. REFERENCE THE FLOW SWITCH KIT INSTRUCTIONS FOR ADDITIONAL DETAILS.
6. UNITS WITH A CUPRO-NICKEL COIL, WILL HAVE A FLOW SWITCH INSTALLED ON THE SOURCE SIDE THAT IS WIRED TO THE FSI AND FS2 TERMINALS ON THE LOCKOUT BOARD, AS SHOWN IN DIAGRAM #2.

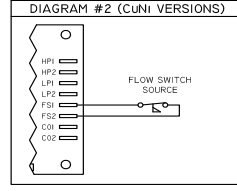
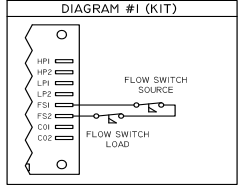

Section 9: Wiring Diagrams

WATER-TO-WATER UNIT, TWO STAGE, THREE PHASE, 208/230V, 60HZ, COMMERCIAL *WDI20

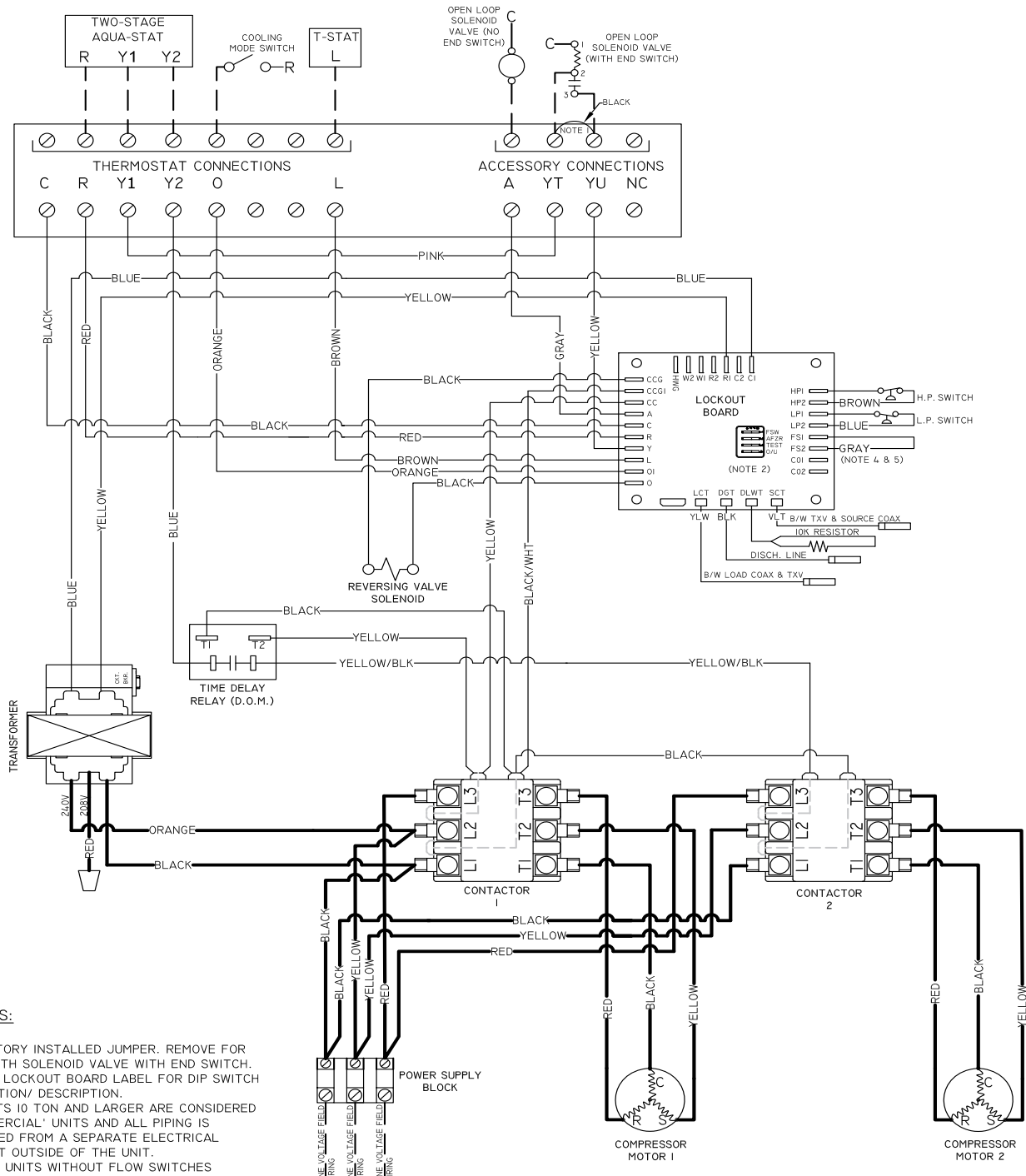

NOTES:

1. FACTORY INSTALLED JUMPER. REMOVE FOR USE WITH SOLENOID VALVE WITH END SWITCH.
2. SEE LOCKOUT BOARD LABEL FOR DIP SWITCH SELECTION/ DESCRIPTION.
3. UNITS 10 TON AND LARGER ARE CONSIDERED 'COMMERCIAL' UNITS AND ALL PIPING IS HANDLED FROM A SEPARATE ELECTRICAL CIRCUIT OUTSIDE OF THE UNIT.
4. FOR UNITS WITHOUT FLOW SWITCHES (COPPER-BPHE CONFIGURATIONS), AN OPTIONAL EXTERNAL FLOW SWITCH KIT IS AVAILABLE. THE GRAY JUMPER WIRE, THAT GOES BETWEEN FSI AND FS2, WILL NEED TO BE REMOVED AND THE SWITCHES SHOULD BE WIRED IN SERIES TO THE LOCKOUT BOARD, AS SHOWN IN **DIAGRAM #1**. REFERENCE THE FLOW SWITCH KIT INSTRUCTIONS FOR ADDITIONAL DETAILS.
5. UNITS WITH A CUPRO-NICKEL COIL, WILL HAVE A FLOW SWITCH INSTALLED ON THE SOURCE SIDE THAT IS WIRED TO THE FSI AND FS2 TERMINALS ON THE LOCKOUT BOARD, AS SHOWN IN **DIAGRAM #2**.

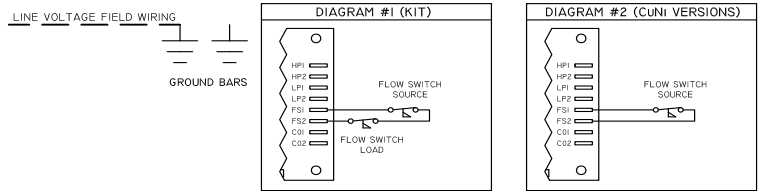

Section 9: Wiring Diagrams

WATER-TO-WATER UNIT, TWO STAGE, THREE PHASE, 208/230V, 60HZ, DSH, COMMERCIAL *WDI20

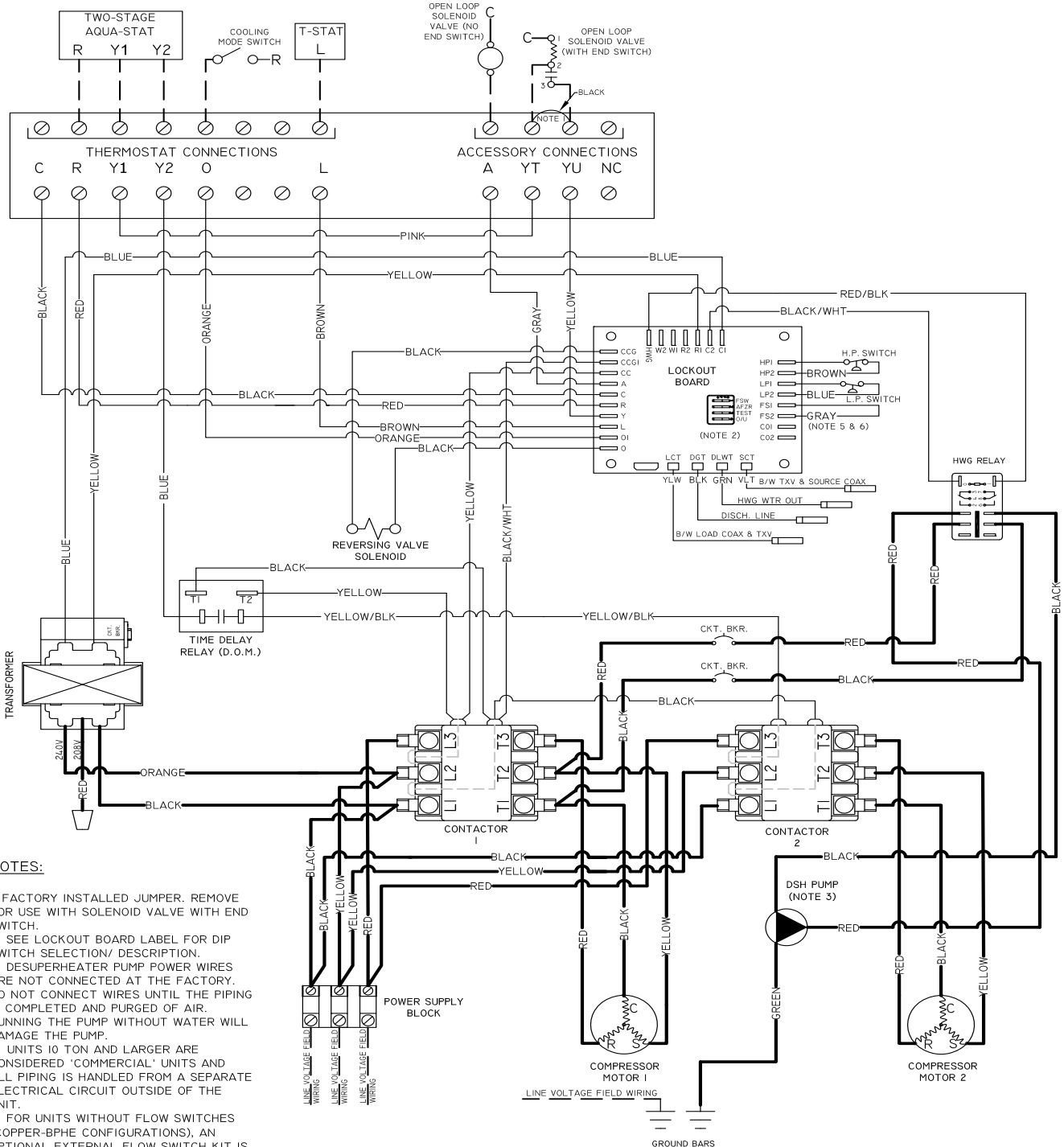

NOTES:

1. FACTORY INSTALLED JUMPER. REMOVE FOR USE WITH SOLENOID VALVE WITH END SWITCH.
2. SEE LOCKOUT BOARD LABEL FOR DIP SWITCH SELECTION/ DESCRIPTION.
3. DESUPERHEATER PUMP POWER WIRES ARE NOT CONNECTED AT THE FACTORY. DO NOT CONNECT WIRES UNTIL THE PIPING IS COMPLETED AND PURGED OF AIR. RUNNING THE PUMP WITHOUT WATER WILL DAMAGE THE PUMP.
4. UNITS 10 TON AND LARGER ARE CONSIDERED 'COMMERCIAL' UNITS AND ALL PIPING IS HANDLED FROM A SEPARATE ELECTRICAL CIRCUIT OUTSIDE OF THE UNIT.
5. FOR UNITS WITHOUT FLOW SWITCHES (COPPER-BPHE CONFIGURATIONS), AN OPTIONAL EXTERNAL FLOW SWITCH KIT IS AVAILABLE. THE GRAY JUMPER WIRE, THAT GOES BETWEEN FSI AND FS2, WILL NEED TO BE REMOVED AND THE SWITCHES SHOULD BE WIRED IN SERIES TO THE LOCKOUT BOARD, AS SHOWN IN DIAGRAM #1. REFERENCE THE FLOW SWITCH KIT INSTRUCTIONS FOR ADDITIONAL DETAILS.
6. UNITS WITH A CUPRO-NICKEL COIL, WILL HAVE A FLOW SWITCH INSTALLED ON THE SOURCE SIDE THAT IS WIRED TO THE FSI AND FS2 TERMINALS ON THE LOCKOUT BOARD, AS SHOWN IN DIAGRAM #2.

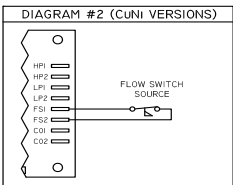
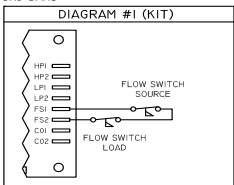

Section 9: Wiring Diagrams

WATER-TO-WATER UNIT, TWO STAGE, THREE PHASE, 460V, 60HZ, COMMERCIAL *WDI20

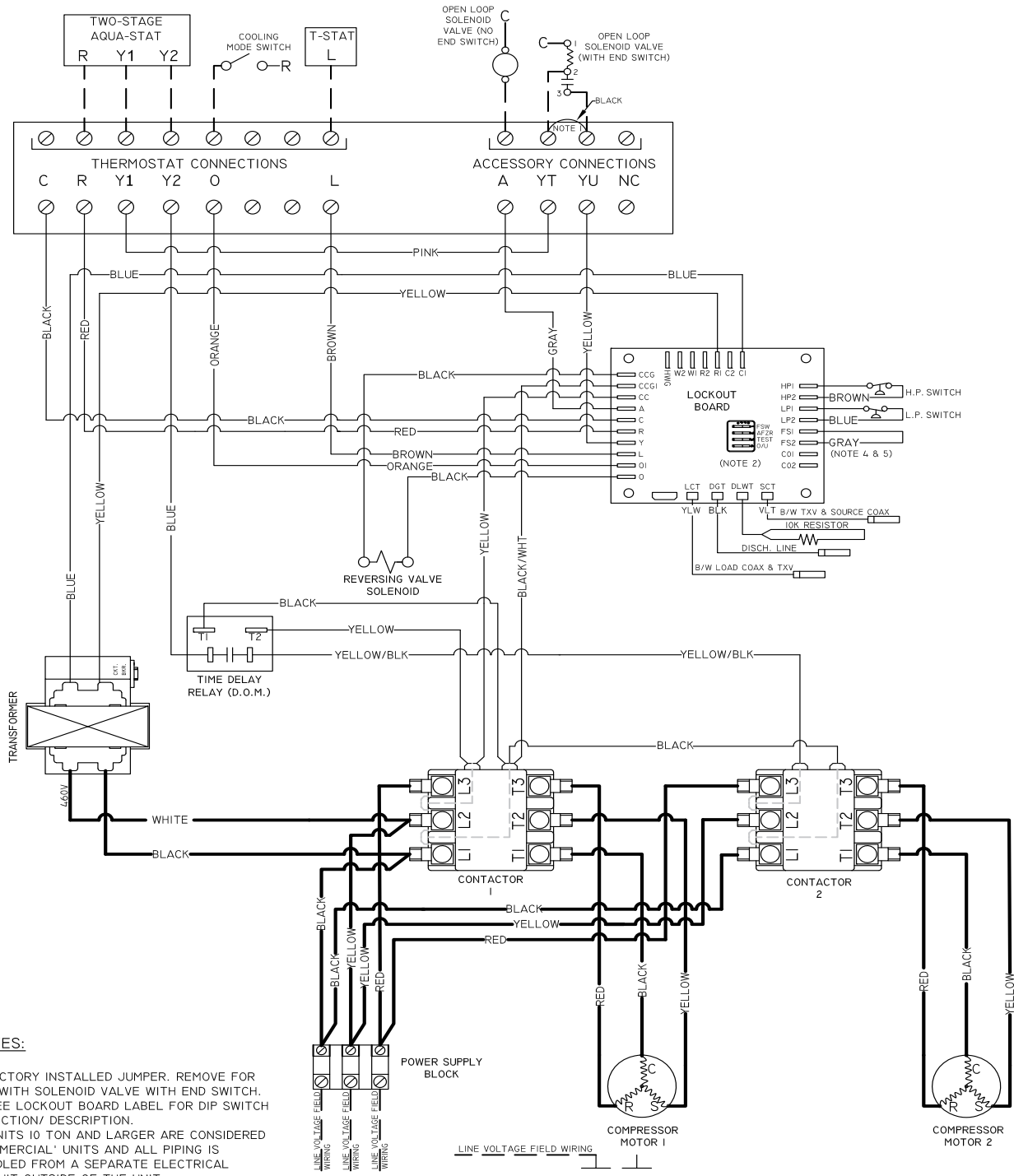

NOTES:

1. FACTORY INSTALLED JUMPER. REMOVE FOR USE WITH SOLENOID VALVE WITH END SWITCH.
2. SEE LOCKOUT BOARD LABEL FOR DIP SWITCH SELECTION/ DESCRIPTION.
3. UNITS 10 TON AND LARGER ARE CONSIDERED 'COMMERCIAL' UNITS AND ALL PIPING IS HANDLED FROM A SEPARATE ELECTRICAL CIRCUIT OUTSIDE OF THE UNIT.
4. FOR UNITS WITHOUT FLOW SWITCHES (COPPER-BPHE CONFIGURATIONS), AN OPTIONAL EXTERNAL FLOW SWITCH KIT IS AVAILABLE. THE GRAY JUMPER WIRE, THAT GOES BETWEEN FS1 AND FS2, WILL NEED TO BE REMOVED AND THE SWITCHES SHOULD BE WIRED IN SERIES TO THE LOCKOUT BOARD, AS SHOWN IN **DIAGRAM #1**. REFERENCE THE FLOW SWITCH KIT INSTRUCTIONS FOR ADDITIONAL DETAILS.
5. UNITS WITH A CUPRO-NICKEL COIL, WILL HAVE A FLOW SWITCH INSTALLED ON THE SOURCE SIDE THAT IS WIRED TO THE FS1 AND FS2 TERMINALS ON THE LOCKOUT BOARD, AS SHOWN IN **DIAGRAM #2**.

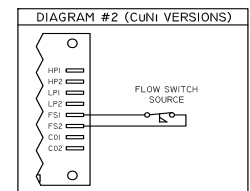
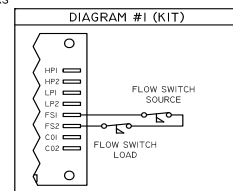

Section 9: Wiring Diagrams

WATER-TO-WATER UNIT, TWO STAGE, THREE PHASE, 460V, 60HZ, DSH, COMMERCIAL *WDI20

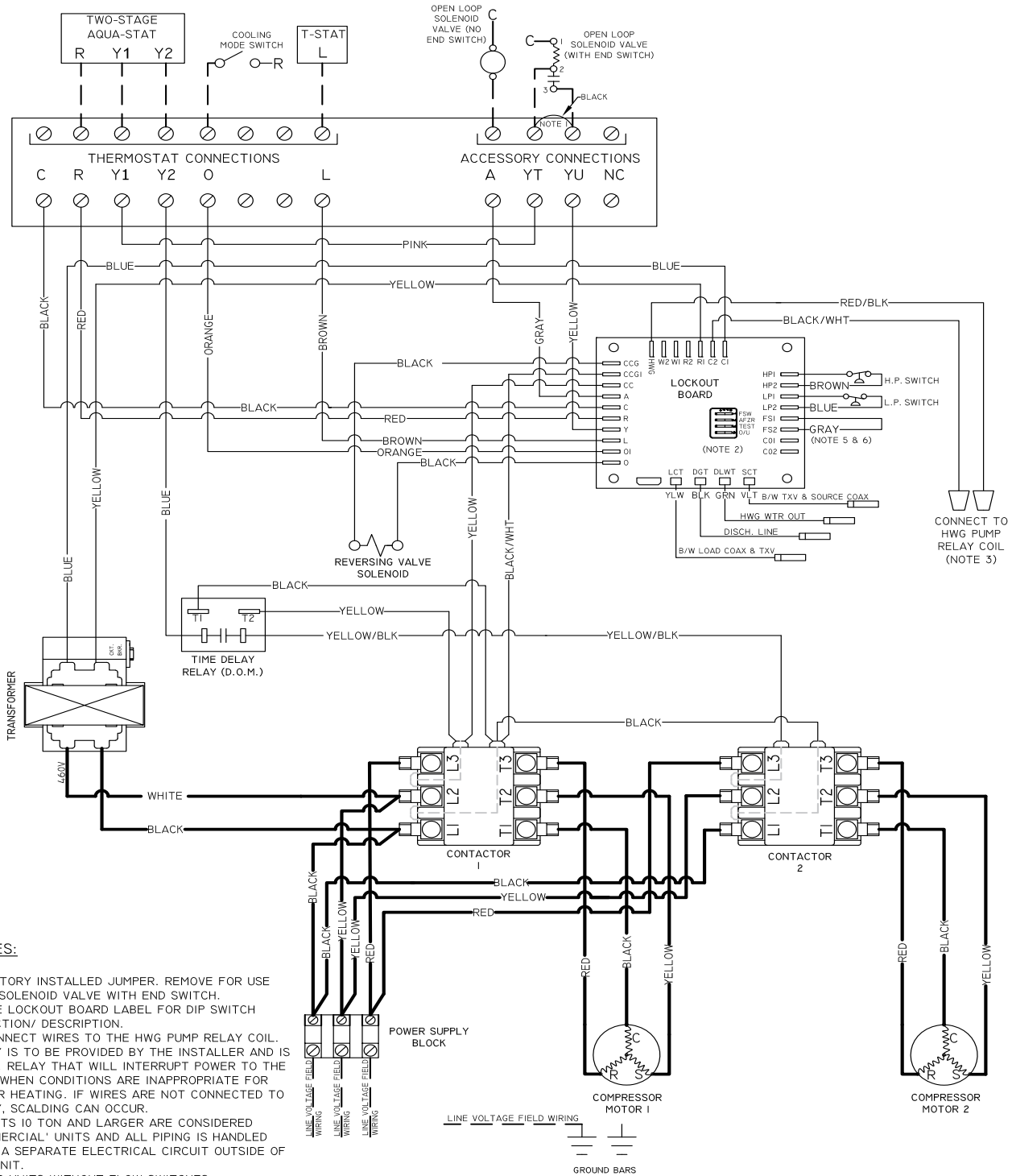

NOTES:

1. FACTORY INSTALLED JUMPER. REMOVE FOR USE WITH SOLENOID VALVE WITH END SWITCH.
2. SEE LOCKOUT BOARD LABEL FOR DIP SWITCH SELECTION/ DESCRIPTION.
3. CONNECT WIRES TO THE HWG PUMP RELAY COIL. RELAY IS TO BE PROVIDED BY THE INSTALLER AND IS A N.C. RELAY THAT WILL INTERRUPT POWER TO THE PUMP WHEN CONDITIONS ARE INAPPROPRIATE FOR WATER HEATING. IF WIRES ARE NOT CONNECTED TO RELAY, SCALDING CAN OCCUR.
4. UNITS 10 TON AND LARGER ARE CONSIDERED 'COMMERCIAL' UNITS AND ALL PIPING IS HANDLED FROM A SEPARATE ELECTRICAL CIRCUIT OUTSIDE OF THE UNIT.
5. FOR UNITS WITHOUT FLOW SWITCHES (COPPER-BPHE CONFIGURATIONS), AN OPTIONAL EXTERNAL FLOW SWITCH KIT IS AVAILABLE. THE GRAY JUMPER WIRE, THAT GOES BETWEEN FS1 AND FS2, WILL NEED TO BE REMOVED AND THE SWITCHES SHOULD BE WIRED IN SERIES TO THE LOCKOUT BOARD, AS SHOWN IN DIAGRAM #1. REFERENCE THE FLOW SWITCH KIT INSTRUCTIONS FOR ADDITIONAL DETAILS.
6. UNITS WITH A CUPRO-NICKEL COIL, WILL HAVE A FLOW SWITCH INSTALLED ON THE SOURCE SIDE THAT IS WIRED TO THE FS1 AND FS2 TERMINALS ON THE LOCKOUT BOARD, AS SHOWN IN DIAGRAM #2.

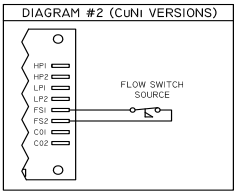
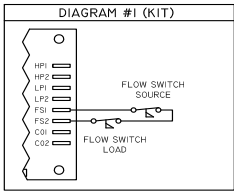

Section 10: Equipment Start-Up Procedures

Equipment Start-Up Form

Customer Name: _____

Customer Address: _____

Model #: _____ Serial #: _____

Dealer Name: _____

Distributor Name: _____ Start-up Date: _____

| Loop Type: Open Closed (Circle One) | | | | | | | | | |
|-------------------------------------|---------|-----|---------|-----|----------------------|---------|----|---------|---|
| Flow Rate | Cooling | | Heating | | Unit Electrical Data | Cooling | | Heating | |
| Source Water Pressure In | | PSI | | PSI | Line Voltage | | V | | |
| Source Water Pressure Out | | PSI | | PSI | Total Unit Amps | | A | | A |
| Source Water Pressure Drop | | PSI | | PSI | Compressor Amps | | A | | A |
| Flow Rate | | GPM | | GPM | Wire Size | | GA | | |
| *Check pressure drop chart for GPM | | | | | Circuit Breaker Size | | A | | |

| Source Water Temp. Difference | Cooling | | Heating | |
|-------------------------------------|---------|----|---------|----|
| Source Water Temperature In | | °F | | °F |
| Source Water Temperature Out | | °F | | °F |
| Source Water Temperature Difference | | °F | | °F |

| Heat of Rejection/Extraction | Cooling | | Heating | |
|------------------------------|---------|--------|---------|--------|
| Heat of Rejection | | BTU/HR | | |
| Heat Of Extraction | | | | BTU/HR |

Heat of Extraction/Rejection = GPM X Water Temp. Difference X 500 (Water - Open Loop)

Heat of Extraction/Rejection = GPM X Water Temp. Difference X 485 (Water & Antifreeze - Closed Loop)

| Load Water Temp. Difference | Cooling | | Heating | |
|-----------------------------------|---------|----|---------|----|
| Load Water Temperature In | | °F | | °F |
| Load Water Temperature Out | | °F | | °F |
| Load Water Temperature Difference | | °F | | °F |

| Air Temperature Difference | Cooling | Heating | |
|----------------------------|---------|---------|----|
| Supply Air Temperature | | °F | °F |
| Return Air Temperature | | °F | °F |
| Air Temp. Difference | | °F | °F |

*Confirm auxiliary heaters are de-energized for the above readings.

| Auxiliary Heat Operation Only | Heating | |
|-------------------------------|---------|----|
| Supply Air Temperature | | °F |
| Return Air Temperature | | °F |
| Air Temp. Difference | | °F |

| Auxiliary Heat Electrical Data | Heating | |
|---|---------|----|
| Line Voltage | | V |
| Total Amperage (Full kW - All Stages) | | A |
| Wire Size | | GA |
| Breaker Size | | A |
| CFM = (Watts X 3.413) ÷ (Air Temp. Difference X 1.08) | | |
| Watts = Volts X Auxiliary Heater Amps | | |

Installer/Technician: _____ Date: _____

Section 10: Equipment Start-Up Procedures

Equipment Start-Up Process Form

Check the following before power is applied to the equipment

Caution: Do not start-up the unit until the new structure is ready to be occupied

Electrical:

- Geothermal unit high voltage wiring is installed correctly
- Geothermal unit high voltage wiring and breaker are the correct size
- Auxiliary electric heaters are wired and installed correctly
- Circulating pumps are wired and fused (if necessary) correctly
- Desuperheater pump is NOT wired, unless piping is complete and all air is purged
- Low voltage wiring is correct and completely installed

Plumbing:

- Pipe and pump sizes are correct
- Air is purged from all lines
- Antifreeze is installed
- All valves are open, including those on the flow center
- Condensate is trapped and piped to the drain

Ductwork:

- Filter is installed and clean
- Packaging is removed from the blower assembly
- Blower turns freely
- Canvas connections installed on supply plenum & return drop

Equipment Start-Up

1. Energize geothermal unit with high voltage.
2. Set the thermostat to "Heat" or "Cool." Adjust set point to energize the unit. System will energize after delays expire (typically a five minute delay).
3. Check water flow with a flow meter (non-pressurized) or pressure drop conversion (pressurized). Pressure drop tables must be used to convert the pressure drop to GPM. The pressure drop can be obtained by checking water pressure in and water pressure out at the P/T ports.
4. Check the geothermal unit's electrical readings listed in the Unit Electrical Data table.
5. Check the source water temperature in and out at the P/T ports (use insertion probe). Allow 10 minutes of operation before recording temperature drop.
6. Calculate the heat of extraction or heat of rejection.
7. Check the temperature difference of the load coax (water-to-water) or air coil (water-to-air). P/T ports are recommended for use on the load side, but the line temperatures can be used to check the temperature difference.
8. Change the mode of the thermostat and adjust the set point to energize the unit. Check the data in opposite mode as the previous tests. Amp draws as well as temperature differences and flow rate should be recorded.
9. Check auxiliary heat operation by adjusting the thermostat set point 5°F above the room temperature in "Heat" mode or set thermostat to "Emergency." Record voltage, amperage, and air temperature difference.

Section 10: Equipment Start-Up Procedures

Operating Parameters

| Source EWT | Source Flow | Load Flow | Load EWT | Full Load Heating-No Hot Water Generation | | | | | |
|------------|-------------|-----------|----------|---|---------|------------|-----------|------------------------|----------------------|
| | | | | Discharge | Suction | Subcooling | Superheat | Source Water Temp Drop | Load Water Temp Rise |
| °F | GPM/Ton | GPM/Ton | °F | PSIG | PSIG | °F | °F | °F | °F |
| 30 | 1.5 | 3.0 | 85 | 298-353 | 59-94 | 11-26 | 6-14 | 7-11 | 4-9 |
| | | | 95 | 345-401 | 61-96 | 10-25 | 5-13 | 7-11 | 4-9 |
| | | | 110 | 418-478 | 63-99 | 8-24 | 4-13 | 5-10 | 4-8 |
| | 3.0 | | 85 | 271-322 | 66-99 | 6-20 | 7-13 | 3-8 | 5-10 |
| | | | 95 | 314-367 | 68-102 | 5-20 | 5-12 | 3-8 | 5-10 |
| | | | 110 | 382-437 | 70-105 | 3-18 | 4-12 | 2-7 | 4-10 |
| 50 | 1.5 | 3.0 | 85 | 310-366 | 87-120 | 12-28 | 6-13 | 11-15 | 6-10 |
| | | | 95 | 358-416 | 89-124 | 11-27 | 4-12 | 10-15 | 6-10 |
| | | | 110 | 435-496 | 92-127 | 9-26 | 4-12 | 9-13 | 6-10 |
| | 3.0 | | 85 | 282-334 | 96-128 | 7-22 | 9-14 | 5-10 | 7-12 |
| | | | 95 | 326-380 | 99-132 | 6-21 | 7-13 | 5-10 | 7-12 |
| | | | 110 | 397-453 | 102-135 | 4-20 | 7-13 | 4-9 | 6-12 |
| 70 | 1.5 | 3.0 | 85 | 324-380 | 116-151 | 13-29 | 6-15 | 15-20 | 8-13 |
| | | | 95 | 374-432 | 119-155 | 12-27 | 5-14 | 14-19 | 8-12 |
| | | | 110 | 454-515 | 123-160 | 11-27 | 4-15 | 13-17 | 8-12 |
| | 3.0 | | 85 | 295-347 | 128-161 | 8-23 | 11-18 | 8-13 | 9-15 |
| | | | 95 | 341-395 | 132-166 | 7-22 | 10-17 | 7-13 | 9-15 |
| | | | 110 | 414-470 | 135-171 | 5-21 | 10-18 | 6-12 | 9-14 |
| 90 | 1.5 | 3.0 | 85 | 336-393 | 144-182 | 15-29 | 9-18 | 19-24 | 11-15 |
| | | | 95 | 388-447 | 148-188 | 13-27 | 7-17 | 19-23 | 10-15 |
| | | | 110 | 470-533 | 152-193 | 12-27 | 7-18 | 17-21 | 10-14 |
| | 3.0 | | 85 | 306-359 | 159-195 | 9-24 | 16-23 | 10-16 | 11-17 |
| | | | 95 | 354-408 | 164-201 | 8-22 | 15-22 | 9-15 | 11-17 |
| | | | 110 | 430-486 | 168-207 | 6-21 | 14-23 | 8-12 | 11-15 |
| Source EWT | Source Flow | Load Flow | Load EWT | Full Load Cooling-No Hot Water Generation | | | | | |
| | | | | Discharge | Suction | Subcooling | Superheat | Source Water Temp Rise | Load Water Temp Drop |
| °F | GPM/Ton | GPM/Ton | °F | PSIG | PSIG | °F | °F | °F | °F |
| 50 | 1.5 | 3.0 | 40 | 173-242 | 68-104 | 12-28 | 5-16 | 13-19 | 4-9 |
| | | | 45 | 173-242 | 75-110 | 12-28 | 5-15 | 14-20 | 4-9 |
| | | | 50 | 173-242 | 81-117 | 12-28 | 5-15 | 15-22 | 5-10 |
| | 3.0 | | 40 | 156-221 | 76-110 | 8-23 | 6-15 | 6-11 | 5-10 |
| | | | 45 | 156-221 | 83-117 | 7-23 | 7-16 | 6-12 | 5-10 |
| | | | 50 | 156-221 | 90-124 | 7-23 | 7-16 | 7-13 | 6-11 |
| 70 | 1.5 | 3.0 | 40 | 246-302 | 72-106 | 14-26 | 4-14 | 13-19 | 4-9 |
| | | | 45 | 246-302 | 78-112 | 13-26 | 4-14 | 14-20 | 4-9 |
| | | | 50 | 246-302 | 85-119 | 13-26 | 4-14 | 15-21 | 5-10 |
| | 3.0 | | 40 | 223-276 | 79-113 | 8-21 | 6-14 | 6-11 | 4-9 |
| | | | 45 | 223-276 | 87-119 | 8-20 | 7-14 | 6-12 | 5-10 |
| | | | 50 | 223-276 | 94-127 | 8-20 | 7-14 | 7-12 | 5-10 |
| 90 | 1.5 | 3.0 | 40 | 326-383 | 74-108 | 12-27 | 4-13 | 13-19 | 3-8 |
| | | | 45 | 329-386 | 81-114 | 12-28 | 5-13 | 14-20 | 4-8 |
| | | | 50 | 332-389 | 88-121 | 12-28 | 5-13 | 15-21 | 4-9 |
| | 3.0 | | 40 | 296-349 | 82-114 | 7-22 | 6-13 | 6-11 | 4-9 |
| | | | 45 | 299-352 | 90-121 | 7-22 | 7-13 | 6-11 | 4-9 |
| | | | 50 | 302-356 | 97-129 | 7-23 | 7-14 | 7-12 | 5-10 |
| 110 | 1.5 | 3.0 | 40 | 424-485 | 77-112 | 9-25 | 3-12 | 13-19 | 3-7 |
| | | | 45 | 428-490 | 84-119 | 10-26 | 3-12 | 13-20 | 3-8 |
| | | | 50 | 432-494 | 92-126 | 10-26 | 3-12 | 14-21 | 3-8 |
| | 3.0 | | 40 | 387-443 | 85-119 | 4-20 | 5-12 | 6-11 | 3-8 |
| | | | 45 | 391-447 | 93-126 | 4-20 | 5-13 | 6-11 | 3-8 |
| | | | 50 | 395-451 | 101-134 | 4-21 | 6-13 | 6-12 | 4-9 |

Section 10: Equipment Start-Up Procedures

Pressure Drop Tables

| Model | GPM | Source Pressure Drop | | Source (CuNi) Pressure Drop | | Load Pressure Drop | |
|-------|-----|----------------------|-------|-----------------------------|-------|--------------------|-------|
| | | 40 °F | | 40 °F | | 40 °F | |
| | | PSI | FT HD | PSI | FT HD | PSI | FT HD |
| WS036 | 6 | 1.2 | 2.8 | 2 | 4.6 | 1.2 | 2.8 |
| | 7 | 1.3 | 3.0 | 2.1 | 4.8 | 1.3 | 3.0 |
| | 8 | 1.5 | 3.5 | 2.7 | 6.2 | 1.5 | 3.5 |
| | 9 | 1.6 | 3.7 | | | 1.6 | 3.7 |
| | 10 | 2 | 4.6 | | | 2 | 4.6 |
| | 11 | 2.1 | 4.8 | | | 2.1 | 4.8 |
| WS048 | 8 | 1.9 | 4.4 | 2.7 | 6.2 | 1.9 | 4.4 |
| | 9 | 2 | 4.6 | 2.8 | 6.5 | 2 | 4.6 |
| | 10 | 2.1 | 4.8 | 3.8 | 8.8 | 2.1 | 4.8 |
| | 11 | 2.2 | 5.1 | 4.1 | 9.5 | 2.2 | 5.1 |
| | 12 | 2.3 | 5.3 | | | 2.3 | 5.3 |
| | 13 | 2.4 | 5.5 | | | 2.4 | 5.5 |
| | 14 | 2.5 | 5.8 | | | 2.5 | 5.8 |
| WS060 | 10 | 2 | 4.6 | 3.8 | 8.8 | 2 | 4.6 |
| | 12 | 2.2 | 5.1 | 5.2 | 12.0 | 2.2 | 5.1 |
| | 13 | 2.4 | 5.5 | | | 2.4 | 5.5 |
| | 14 | 2.5 | 5.8 | | | 2.5 | 5.8 |
| | 15 | 2.6 | 6.0 | | | 2.6 | 6.0 |
| | 16 | 3.1 | 7.2 | | | 3.1 | 7.2 |
| | 17 | 3.4 | 7.8 | | | 3.4 | 7.8 |
| | 18 | 4.1 | 9.5 | | | 4.1 | 9.5 |
| WS072 | 12 | 1.6 | 3.7 | 6.2 | 14.3 | 1.6 | 3.7 |
| | 14 | 1.8 | 4.2 | 6.2 | 14.3 | 1.8 | 4.2 |
| | 15 | 1.9 | 4.4 | 7.8 | 18.0 | 1.9 | 4.4 |
| | 16 | 2.1 | 4.8 | 8.2 | 18.9 | 2.1 | 4.8 |
| | 18 | 2.5 | 5.8 | | | 2.5 | 5.8 |
| | 19 | 2.7 | 6.2 | | | 2.7 | 6.2 |
| | 20 | 3 | 6.9 | | | 3 | 6.9 |
| | 21 | 3.2 | 7.4 | | | 3.2 | 7.4 |
| WS084 | 14 | 1.8 | 4.2 | 3.9 | 9.0 | 2.5 | 5.8 |
| | 16 | 2.1 | 4.8 | 5 | 11.5 | 2.6 | 6.0 |
| | 18 | 2.5 | 5.8 | 7 | 16.1 | 2.7 | 6.2 |
| | 20 | 3 | 6.9 | | | 3.3 | 7.6 |
| | 22 | 3.4 | 7.8 | | | 3.9 | 9.0 |
| | 24 | 3.9 | 9.0 | | | 4.1 | 9.5 |
| | 25 | 4 | 9.2 | | | 4.2 | 9.7 |
| WD120 | 20 | 3 | 6.9 | 9.5 | 21.9 | 3.1 | 7.2 |
| | 22 | 3.4 | 7.8 | 11 | 25.4 | 3.3 | 7.6 |
| | 24 | 3.9 | 9.0 | 15 | 34.6 | 3.4 | 7.8 |
| | 26 | 4.5 | 10.4 | | | 3.4 | 7.8 |
| | 28 | 5.3 | 12.2 | | | 3.6 | 8.3 |
| | 30 | 6.1 | 14.1 | | | 3.7 | 8.5 |
| | 32 | 7.2 | 16.6 | | | 3.9 | 9.0 |
| | 34 | 8.3 | 19.1 | | | 4.2 | 9.7 |

Section 10: Equipment Start-Up Procedures

Performance Check

Heat of Extraction(HE)/Rejection(HR)

Record information on the Unit Start-up Form

Equipment should be in operation for a minimum of 10 minutes in either mode – **WITH THE HOT WATER GENERATOR TURNED OFF.**

1. Determine flow rate in gallons per minute
 - a. Check entering water temperature
 - b. Check entering water pressure
 - c. Check leaving water pressure

Once this information is recorded, find corresponding entering water temperature column in Specification Manual for unit. Find pressure differential in PSI column in Spec Manual. Then read the GPM column in Spec Manual to determine flow in GPM.

1. Check leaving water temperature of unit.
FORMULA: $GPM \times \text{water temp diff} \times 485$ (antifreeze) or 500 (fresh water) = HE or HR in BTU/HR

A 10% variance from Spec Manual is allowed. Always use the same pressure gauge & temperature measuring device. Water flow must be in range of Specification Manual. If system has too much water flow, performance problems should be expected

Section 11: Troubleshooting

QR Codes for Maintenance and Troubleshooting Tips Videos

Select the topic for your maintenance need. Scan the QR code to access the video. Follow the directions and tips provided to make the project easier to complete



ECM Temporary Motor Replacement



Compressor Troubleshooting



ECM Motor Troubleshooting



Variable Speed Flow Centers



Troubleshooting a TXV



Return Conversion for a XT or CT



Heat Of Extraction and Rejection

A: Unit will not start in either cycle

| | |
|---|---|
| Thermostat | Set thermostat on heating and highest temperature setting. Unit should run. Set thermostat on cooling and lowest temperature setting. Unit should run. Set fan to On position. Fan should run. If unit does not run in any position, disconnect wires at heat pump terminal block and jump R, G, Y. Unit should run in heating. If unit runs, replace thermostat with correct thermostat only. |
| Loose or broken wires | Tighten or replace wires. |
| Blown Fuse/ Tripped Circuit Breakers | Check fuse size, replace fuse or reset circuit breaker. Check low voltage circuit breaker. |
| Low Voltage Circuit | Check 24 volt transformer. If burned out or less than 24 volt, replace. Before replacing, verify tap setting and correct if necessary. |
| Water Flow (runs for 30 sec) | If water flow is low (less than 3.5 GPM), unit will not start. Make sure Pump Module or solenoid valve is connected (see wiring diagram). Water has to flow through the heat exchanger in the right direction (see labels at water fitting connections) before the compressor can start. If water flow is at normal flow, use an ohmmeter to check if you get continuity at the flow switch. If no switch is open and flow is a normal flow, remove switch and check for stuck particles or bad switch. |

B: Unit Running Normal, But SPACE Temperature Is Unstable

| | |
|------------|--|
| Thermostat | Thermostat is getting a draft of cold or warm air. Make sure that the wall or hole used to run thermostat wire from the ceiling or basement is sealed, so no draft can come to the thermostat. Faulty Thermostat (Replace). |
|------------|--|

C: No water flow

| | |
|----------------|--|
| Pump Module | Make sure Pump Module is connected to the control box relay (check all electrical connections). For non-pressurized systems, check water level in Pump Module. If full of water, check pump. Close valve on the pump flanges and loosen pump. Take off pump and see if there is an obstruction in the pump. If pump is defective, replace. For pressurized systems, check loop pressure. Repressurize if necessary. May require re-flushing if there is air in the loop. |
| Solenoid valve | Make sure solenoid valve is connected. Check solenoid. If defective, replace. |

D: In heating or cooling mode, unit output is low

| | |
|--------------------|---|
| Water | Water flow & temperature insufficient. |
| Load Side Flow | Check speed setting, check nameplate or data manual for proper speed, and correct speed setting. Check for dirty air filter—Clean or replace. Restricted or leaky ductwork. Repair. |
| Refrigerant charge | Refrigerant charge low, causing inefficient operation. Make adjustments only after airflow and water flow are checked. |
| Reversing valve | Defective reversing valve can create bypass of refrigerant to suction side of compressor. Switch reversing valve to heating and cooling mode rapidly. If problem is not resolved, replace valve. Wrap the valve with a wet cloth and direct the heat away from the valve. Excessive heat can damage the valve. Always use dry nitrogen when brazing. Replace filter/drier any time the circuit is opened. |

E: In heating or cooling mode, unit output is low

| | |
|---|--|
| Heat pump will not cool but will heat. Heat pump will not heat but will cool. | Reversing valve does not shift. Check reversing valve wiring. If wired wrong, correct wiring. If reversing valve is stuck, replace valve. Wrap the valve with a wet cloth and direct the heat away from the valve. Excessive heat can damage the valve. Always use dry nitrogen when brazing. Replace filter/drier any time the circuit is opened. |
| Water heat exchanger | Check for high-pressure drop, or low temperature drop across the coil. It could be scaled. If scaled, clean with condenser coil cleaner. |
| System undersized | Recalculate conditioning load. |

F: Water heat exchanger freezes in heating mode

| | |
|-------------|--|
| Water flow | Low water flow. Increase flow. See F. No water flow. |
| Flow Switch | Check switch. If defective, replace. |

G: Excessive head pressure in cooling mode

| | |
|-----------------------|--------------------------------|
| Inadequate water flow | Low water flow, increase flow. |
|-----------------------|--------------------------------|

H: Excessive head pressure in heating mode

| | |
|----------------|---------------------------------------|
| Load Side Flow | See E: Noisy blower and low air flow. |
|----------------|---------------------------------------|

I: Water Dripping from Unit

| | |
|--|--|
| Unit not level | Level unit. |
| Condensation drain line plugged | Unplug condensation line. |
| Water sucking off the air coil in cooling mode | Too much airflow. Duct work not completely installed. If duct work is not completely installed, finish duct work. Check static pressure and compare with air flow chart in spec manual under specific models section. If ductwork is completely installed it may be necessary to reduce CFM. |
| Water sucking out of the drain pan | Install an EZ-Trap or P-Trap on the drain outlet so blower cannot suck air back through the drain outlet. |

Section 11: Troubleshooting

Compressor Troubleshooting Tips

J: COMPRESSOR WON'T START

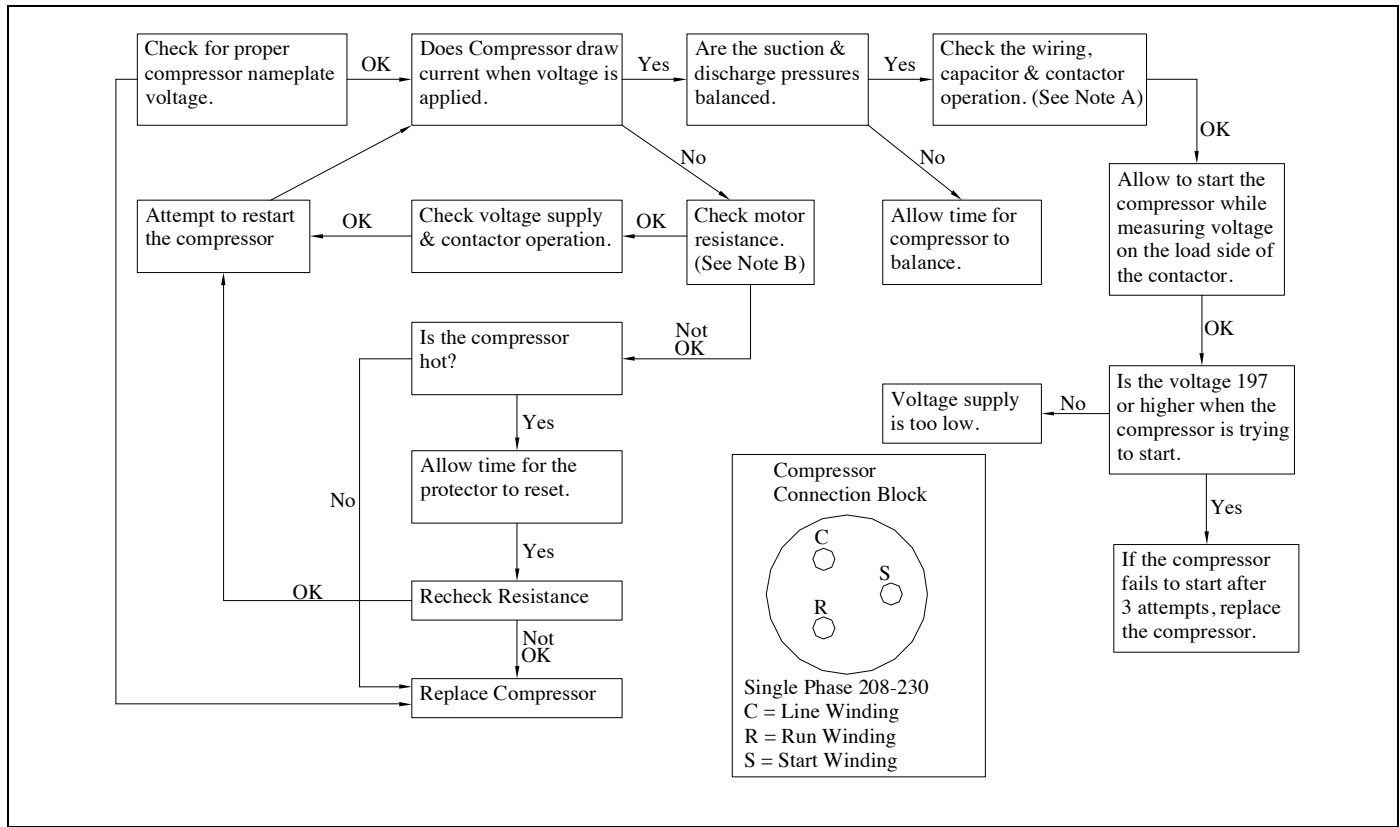

A: Check all terminals, wires & connections for loose or burned wires and connections. Check contactor and 24 Volt coil. Check capacitor connections & check capacitor with capacitor tester.

B: If ohm meter reads 0 (short) resistance from C to S, S to R, R to C or from anyone of one of these terminals to ground (shorted to ground), compressor is bad.

K: COMPRESSOR WON'T PUMP CHART

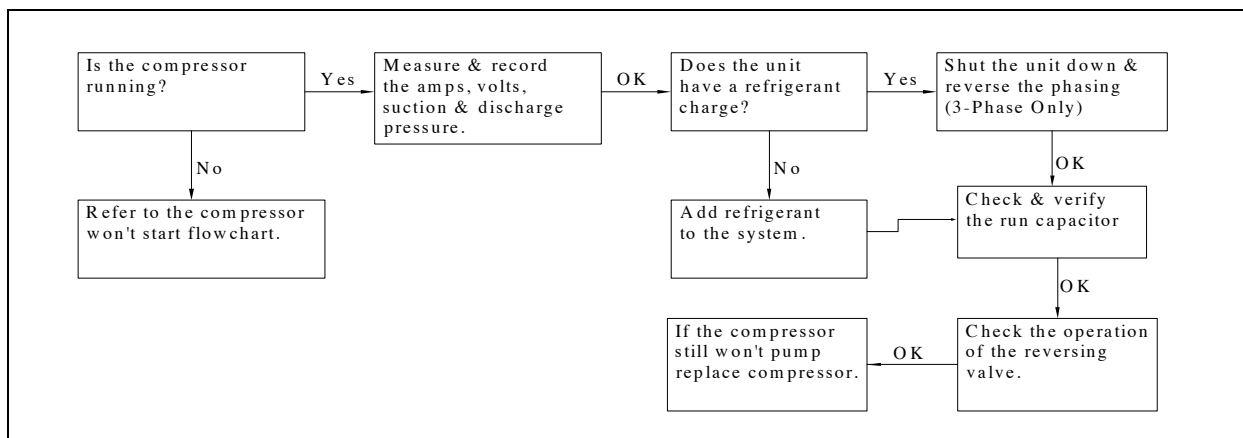

Section 11: Troubleshooting

Refrigeration Troubleshooting

| System Faults | Mode | Discharge Pressure | Suction Pressure | Superheat | Subcooling | Air TD | Water TD | Compressor Amps |
|------------------------|------|--------------------|------------------|-------------|-------------|--------|----------|-----------------|
| Under Charge | Heat | Low | Low | High | Low | Low | Low | Low |
| | Cool | Low | Low | High | Low | Low | Low | Low |
| Over Charge | Heat | High | High/Normal | Normal | High | High | Normal | High |
| | Cool | High | High/Normal | Normal | High | Normal | High | High |
| Low Air Flow | Heat | High | High/Normal | Normal | High/Normal | High | Low | High |
| | Cool | Low | Low/Normal | Low | Normal | High | Low | High/Normal |
| Low Source Water Flow | Heat | Low | Low/Normal | Low | Normal | High | Low | High/Normal |
| | Cool | High | High/Normal | Normal | High/Normal | High | Low | High |
| Low Load Water Flow | Heat | High | High/Normal | Normal | High/Normal | High | Low | High |
| | Cool | Low | Low/Normal | Low | Normal | High | Low | High/Normal |
| Restricted TXV | Heat | High | Low | High | High | Low | Low | Low |
| | Cool | High | Low | High | High | Low | Low | Low |
| TXV Stuck Open | Heat | Low | High/Normal | Low | Low | Low | Low | High |
| | Cool | Low | High/Normal | Low | Low | Low | Low | High |
| Inadequate Compression | Heat | Low | High | High/Normal | Low/Normal | Low | Low | Low |
| | Cool | Low | High | High/Normal | Low/Normal | Low | Low | Low |

Superheat/Subcooling Conditions

| Superheat | Subcooling | Condition |
|-----------|------------|---|
| Normal | Normal | Normal operation |
| Normal | High | Overcharged |
| High | Low | Undercharged |
| High | High | Restriction or TXV is stuck almost closed |
| Low | Low | TXV is stuck open |

Typical R-410A Unit Superheat/Subcooling Values

| Heating - Without Desuperheater | | | | | | | |
|---------------------------------|-------------|---------------------------|-------------------------|-------------|------------|------------------------------|-----------------------------|
| EWT | GPM Per Ton | Discharge Pressure (PSIG) | Suction Pressure (PSIG) | Sub Cooling | Super Heat | Air Temperature Rise (°F-DB) | Water Temperature Drop (°F) |
| 30 | 1.5 | 285-310 | 68-76 | 4-10 | 8-12 | 14-20 | 5-8 |
| | 3 | 290-315 | 70-80 | 4-10 | 8-12 | 16-22 | 3-6 |
| 50 | 1.5 | 315-345 | 100-110 | 6-12 | 9-14 | 22-28 | 7-10 |
| | 3 | 320-350 | 105-115 | 6-12 | 9-14 | 24-30 | 5-8 |
| 70 | 1.5 | 355-395 | 135-145 | 7-12 | 10-15 | 30-36 | 9-12 |
| | 3 | 360-390 | 140-150 | 7-12 | 10-15 | 32-38 | 7-10 |

| Cooling - Without Desuperheater | | | | | | | |
|---------------------------------|-------------|---------------------------|-------------------------|-------------|------------|------------------------------|-----------------------------|
| EWT | GPM Per Ton | Discharge Pressure (PSIG) | Suction Pressure (PSIG) | Sub Cooling | Super Heat | Air Temperature Drop (°F-DB) | Water Temperature Rise (°F) |
| 50 | 1.5 | 220-235 | 120-130 | 10-16 | 12-20 | 20-26 | 19-23 |
| | 3 | 190-210 | 120-130 | 10-16 | 12-20 | 20-26 | 9-12 |
| 70 | 1.5 | 280-300 | 125-135 | 8-14 | 10-16 | 19-24 | 18-22 |
| | 3 | 250-270 | 125-135 | 8-14 | 10-16 | 19-24 | 9-12 |

Section 12: Warranty Forms

Warranty Order & Claim Form



WARRANTY ORDER & CLAIM

PHONE: 618.664.9010 FAX: 618.664.4597 EMAIL: WARRANTY@ENERTECHGEO.COM

ALL WARRANTY REGISTRATIONS SHOULD BE SUBMITTED WITHIN 10 DAYS OF INSTALLATION

COMPANY NAME _____ (Form submitter) DATE _____
PHONE _____ FAX _____ EMAIL _____
ORDERED BY _____ JOB NAME/PO # _____
UNIT Model # _____ Serial # _____
FAILURE DATE _____
SHIP TO _____ HOMEOWNER ADDRESS _____
(If different than company)

Required if claim is for defective flow center
FLOW CENTER MODEL # _____ FLOW CENTER SERIAL # _____

**FAILURE CODES, DESCRIPTION AND LABOR REIMBURSEMENT
MUST BE FOUND IN WARRANTY MANUAL**

| FAILURE CODE | DESCRIPTION | PART NUMBER |
|--------------|-------------|-------------|
| _____ | _____ | _____ |
| _____ | _____ | _____ |
| _____ | _____ | _____ |

LABOR REIMBURSEMENT REQUESTED NO YES

DO YOU NEED PARTS ORDERED? NO YES _____
(If no, and replacement was purchased from another vendor, attach copy of bill if reimbursement is needed.)

OTHER NOTES _____

FOR ENERTECH COMPANIES USE ONLY
SRO# _____ CREDIT MEMO# _____

1) See warranty coverage summary sheet for labor allowances, conditions and exclusions, etc. 2) Warranty start date is ship date from Enertech facility unless proof of startup is presented. 3) Outsourced warranty replacement parts will be reimbursed in the form of credit for the part only. Credit will be no more than the standard equivalent part cost through Enertech. 4) Factory pre-approval is required for anything outside the scope of this document. 5) Fuses, hose kits and items not mentioned on Warranty Coverage Summary are not covered under this program.

Section 12: Warranty Forms

Warranty Registration Form



WARRANTY REGISTRATION

NOW REGISTER ONLINE AT WARRANTY-REGISTRATION.ENERTECHGEO.COM

WARRANTY REGISTRATIONS SHOULD BE SUBMITTED WITHIN 60 DAYS OF INSTALLATION

Model Number _____ Serial Number _____ Install Date _____
This unit is performing [] Satisfactorily [] Not Satisfactorily (please explain) _____

Purchaser/User Name _____ Phone _____
Address _____ City _____ State/Prov _____
Postal Code _____ Email _____

Installer Company Name _____
City _____ State/Prov _____ Email _____

Application
[] Residential New Construction [] Residential Geo Replacement [] Residential Replacement of Electric, Gas or Other
[] Multi-Family (Condo/Townhome/Multiplex) [] Commercial [] Other _____
Use (check all that apply)
[] Space Conditioning [] Domestic Water Heating [] Radiant Heat [] Swimming Pool [] Snow/Ice Melt
[] Other _____
Loop Type
[] Horizontal Loop [] Vertical Loop [] Pond Loop [] Open Loop
Demographics
Household Income [] Under \$30,000 [] \$30,000-\$45,000 [] \$45,000-\$60,000 [] \$60,000-\$75,000 [] \$75,000-\$100,000 [] Over \$100,000
Home Size [] Up to 1500 sq. ft. [] 1501 to 2500 sq. ft. [] 2501 to 4000 sq. ft. [] Over 4000 sq. ft.
Home Location [] Rural [] Urban [] Suburban
Value of Home [] Less than \$100,000 [] \$100,000-\$250,000 [] \$250,000-\$500,000 [] \$500,000-\$1 mil [] Over \$1 mil
Customer Satisfaction
How would you rate your overall satisfaction with your new geothermal system?
[] 1 (Very Dissatisfied) [] 2 [] 3 [] 4 [] 5 [] 6 [] 7 [] 8 [] 9 [] 10 (Very Satisfied)
How would you rate your overall satisfaction with your installing geothermal contractor?
[] 1 (Very Dissatisfied) [] 2 [] 3 [] 4 [] 5 [] 6 [] 7 [] 8 [] 9 [] 10 (Very Satisfied)

MAIL THIS FORM TO:
ENERTECH GLOBAL LLC
2506 SOUTH ELM STREET
GREENVILLE, IL 62246

EMAIL THIS FORM TO:
WARRANTY@ENERTECHGEO.COM

FAX THIS FORM TO:
ENERTECH GLOBAL LLC
618.664.4597

REGISTER ONLINE AT: warranty-registration.enertechgeo.com

Rev 30 DEC 2013B

Revision Table

| Date | Description of Revision | Page |
|-----------|--|---------|
| 10AUG2020 | Minor layout changes made | Various |
| 15NOV2019 | Unit Electrical Data Table updated | 11 |
| 18JUN2019 | AHRI Data removed. Minor layout changes made | Various |
| - | Lockout Board updated | 20 |
| - | Wiring Diagrams updated | 38-43 |
| - | Air Handler Infio removed | ALL |
| - | AHRI Data updated | -- |
| - | Nomenclature(s) updated | -- |
| - | IOM Rev change (Rev D) entered and Unit Data updated | -- |
| - | Fan Chart updated | 36 |
| - | Controls Section Added/Updated | 35-40 |
| - | Wiring Diagrams updated | 42-54 |
| - | WD240/360 Electrical Data Table added | - |
| - | Electrical Data Table updated | 17,20 |
| - | WD240/360 Nomenclature added | 5 |
| - | Wiring Diagrams added | 52,53 |
| - | Updated nomenclature drawing | 4 |
| - | Added removal disposal paragraph | 7 |
| - | Place Ops Parameters | 50 |
| - | Created IOM | All |

This Page Intentionally Left Blank



ENERTECH

ENERGY + TECHNOLOGY

enertechusa.com



Conforms to
UL Std 1995
Certified to
CAN/CSA Std
C22.2 No. 236



Enertech Global is continually working to improve its products. As a result, the pricing, design and specifications of each product may change without notice and may not be as described herein. For the most up-to-date information, please visit our website, or contact our Customer Service department at info@enertechgeo.com. Statements and other information contained herein are not express warranties and do not form the basis of any bargain between the parties, but are merely Enertech Global's opinion or commendation of its products.