INSTALLATION INSTRUCTIONS

GVDM-26

DOMESTIC HOT WATER DESUPERHEATER PUMP MODULE KIT

BMC, Inc.
Bryan, Ohio 43506

Manual: 2100-546B
Supersedes: 2100-546A
File: Volume 1, Tab 9
Date: 04-29-14

CONTENTS

General.....	3
Description.....	3
Location	3
Electrical Connection.....	3
Soldering Tubing.....	3
Installation Procedure – General.....	3
Operation of the Heat Recovery Unit.....	4
Start Up and Check Out	4
Maintenance.....	4
Control Board Sequence of Operation	10

WIRING DIAGRAM

.....	5
-------	---

FIGURES

Figure 1	Mounting Directly onto Unit	6
Figure 2	Air Purge Port.....	7
Figure 3	Remote Mounting & Piping.....	8
Figure 4	Single Tank System.....	9
Figure 5	Thermistor	10
Figure 6	Replacement Parts.....	11

GENERAL

The pump module kit should only be installed by trained technicians. These instructions serve as a guide to the technician installing the pump module kit. They are not intended as a step-by-step procedure with which the mechanically inclined owner can install the unit.

DESCRIPTION

The system is designed to heat domestic water using heat recovered from a water source unit's hot discharge gas.

LOCATION

There are two options for the mounting location of the GVDM-26 Domestic Hot Water Desuperheater Module. First, there are pre-punched mounting holes for it on the side of the geothermal heat pump beneath the filter rack. Factory supplied in the kit are interconnect tubes that connect the pump module to the water source unit (See Figure 1).

The second is to locate the GVDM-26 on a wall adjacent to the geothermal unit or storage tank/water heater. (See Figures 3 and 4.)

Because of potential damage from freezing or condensation, the unit must be located in a conditioned space, therefore the GVDM-26 must be installed indoors.

Locate the storage tank as close to the geothermal heat pump and pump module as the installation permits. Keep in mind that water lines should be a maximum of 25 feet long measured one way. Also, the vertical lift should not exceed 20 feet. This is to keep pressure and heat losses to a minimum.

ELECTRICAL CONNECTION

Line Voltage Connections:

The GVDM-26 is equipped with a standard 115V 3-prong plug. The unit is rated at .9 amps and can normally be plugged into any convenient electrical outlet.

NOTE: Make sure outlet is grounded, and that the circuit will handle the added load. If any concerns in this regard you should run a separate grounded circuit to the main panel.

Low Voltage Connections:

Emitting from the bottom of the GVDM-26 are three (3) wires (Yellow, Red, and Black) that need tied into the 24 volt terminal strip of the GV**S1 so the wall thermostat initiates the desuperheater pump module.

Yellow – Needs to be connected to “Y1” of the low voltage terminal strip.

Red – Needs to be connected to “R” of the low voltage terminal strip.

Black – Needs to be connected to “C” of the low voltage terminal strip.

SOLDERING TUBING

NOTE: The “inlet” (black wire) and “outlet” (red wire) thermistors should be removed from the tubes prior to soldering/brazing operation so they are not damaged. They are clipped onto the “DSH COIL INLET” and from “DSH OUTLET” tubes of the GVDM-26 Module. Once soldering operations are complete, and the tubes have cooled, reattach the sensors and wrap with provided insulation.

INSTALLATION PROCEDURE – GENERAL

Before beginning the installation, turn off all power supplies to the water heater and unit, and shut off the main water supply line.

TWO TANK – In order to realize the maximum energy savings from the heat recovery system, it is recommended that a second water storage tank be installed in addition to the main hot water heater. Fossil fuel fired water heaters must be a two-tank installation.

Tanks specifically intended for hot water storage are available from water heater manufacturers (solar hot water storage tanks). A well insulated electric water heater without the electric heating elements will also make a suitable storage tank.

The size of storage tank should be as large as space and economy permit but in no event should it be less than one-half of the daily water requirements for the occupants. As a guide in estimating the daily family water requirements, The Department of Energy recommends a figure of 16.07 gallons of hot water per day per individual. For example, a family of four would require 64.3 gallons per day (4 x 16.07).

ONE TANK – The single hot water tank may be a new hot water heater (sized to 100% of daily water requirements) or the existing water heater in the case of a retrofit installation. The existing water heater should be drained and flushed to remove **all** loose sediment. This sediment could damage the circulating pump. The bottom heating element should be disconnected.

NOTE: Make sure water heater thermostats are set below 125° on One Tank Unit.

WATER PIPING – All water piping must adhere to all state and local codes. Refer to piping diagrams for recommended one and two tank installations. Piping connections are 1/2 inch nominal copper plumbing.

A cleanable “Y” type strainer should also be included to collect any sediment.



WARNING

Never alter or plug factory installed pressure relief valve on water heater or auxiliary tank.

OPERATION OF THE HEAT RECOVERY UNIT

The pump module is a very simple device containing basic controls and a circulating pump. Heat is transferred from the hot refrigerant (discharge gas) to the cool water.

The operation of the Desuperheater Pump Module is controlled first by the operation of the Geothermal Heat Pump and secondly by internal controls within the Pump Module. A low voltage signal from Thermostat “Y” is connected to the internal control board of the GVDM-26 and acts as the primary on/off switch for the circulating pump.

Also connected to this board is a temperature overlimit device which shuts down the GVDM-26 once inlet water has exceeded 125° so the water cannot create a scald condition.

There are also two (2) thermistor sensors connected to the control board. These thermistors are measuring and controlling to ensure there is a positive heat differential across the water being circulated. When operating in Part Load Condition, there are certain conditions (Ground Loop Temperatures versus Hot Water Temperatures) that potential exists where heat could transfer from the hot water into the refrigeration system instead of the refrigeration system into the hot water. Through the control board logic, these thermistors ensure there is at least 2° positive differential between entering/leaving water temperatures and will shut down the pump accordingly.

START UP AND CHECK OUT

Be sure all **shut off** valves are open and all power supplies are on. Open a hot water faucet to permit any air to bleed from the plumbing.

NOTE: The inherent design of this pump for maximum efficiency means this pump is not self-priming. It is imperative to check that the air has been adequately bled from the system. There is a bleed-port built into the pump module that can be utilized after the system water has been fully restored. See Figure 2 for this bleed port location.

Turn ON the air conditioning system and verify the circulating pump will operate. Feel the “Water to Unit” and “Water from Water Heater” tubes for noticeable difference in temperature. Turn OFF the system and verify that the circulating pump stops.

*NOTE: When checking the refrigerant operating pressures of the ground source heat pump. The GVDM-26 **must be** turned off. With the GVDM-26 operating a wide variance in pressures can result, giving the service technician the indication there is a charge problem when the unit is operating correctly.*

MAINTENANCE

CLEANING THE HEAT EXCHANGER – If scaling of the coil is strongly suspected, the coil can be cleaned with a solution of phosphoric acid (food grade acid). Follow the manufacturer’s directions for the proper mixing and use of cleaning agent.

WIRING DIAGRAM

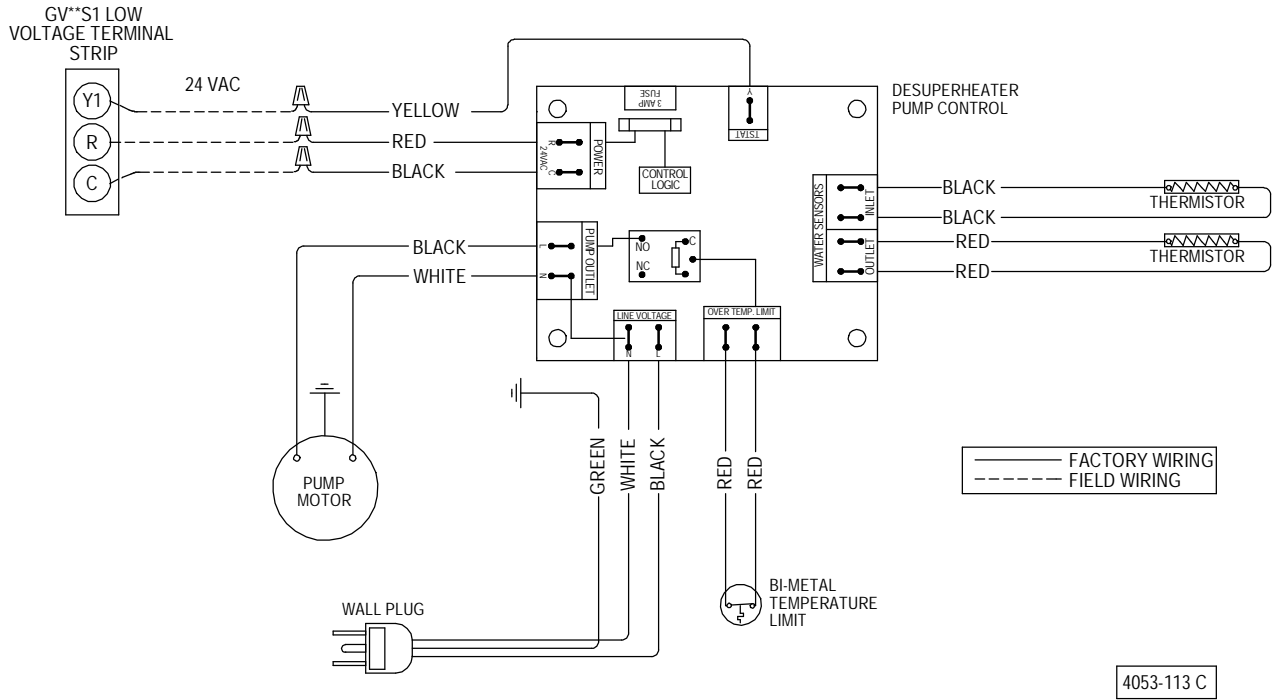
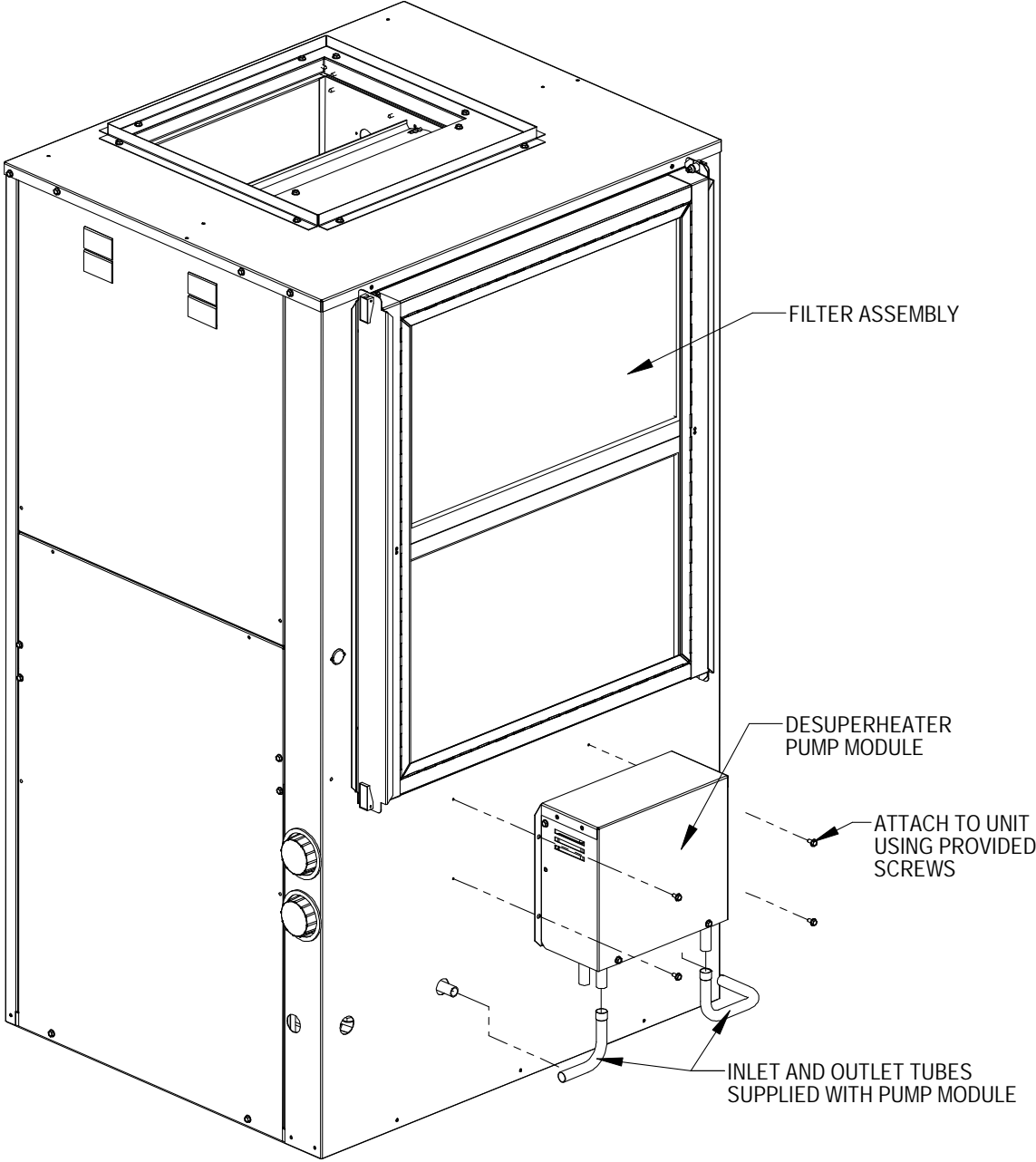

Figure 1
MOUNTING DIRECTLY ONTO UNIT



MIS-2647 A

Figure 2
AIR PURGE PORT

NOTE: TO AVOID DAMAGE BEFORE BRAZING MAKE SURE INLET AND OUTLET THERMISTORS ARE NOT CLIPPED TO TUBES.

AFTER BRAZING IS COMPLETE, INSTALL THERMISTORS TO INLET AND OUTLET TUBES AS SHOWN

AIR PURGE PORT
NOTE: PUMP IS NOT SELF-PRIMING, IT IS RECOMMENDED TO MANUALLY BLEED-OFF AIR.

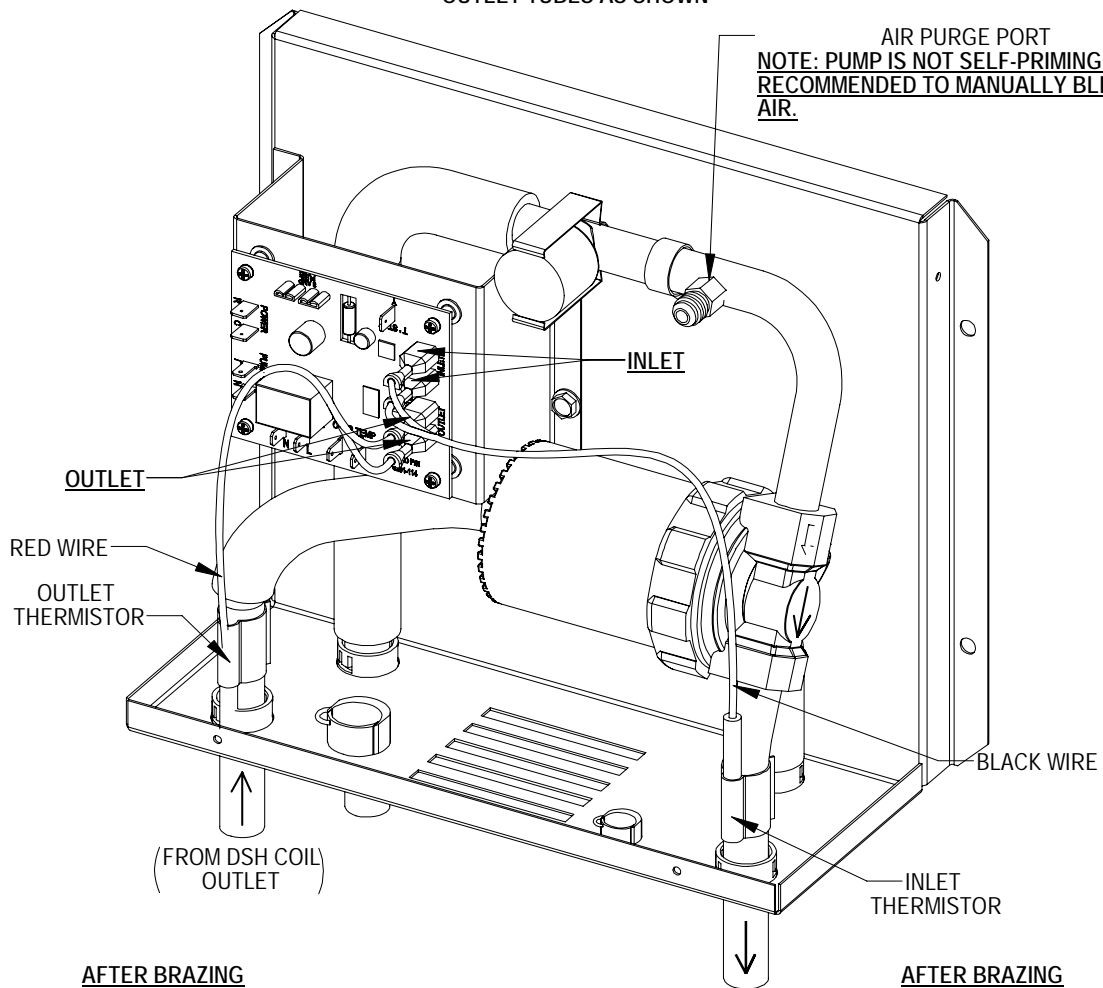

AFTER BRAZING
ATTACH OUTLET THERMISTOR TO INLET TUBE WITH CLIP AS SHOWN

WRAP WITH PROVIDED INSULATION
VERIFY THERMISTOR CONNECTION ON CIRCUIT BOARD (INLET)

AFTER BRAZING
ATTACH INLET THERMISTOR TO OUTLET TUBE WITH CLIP AS SHOWN

WRAP WITH PROVIDED INSULATION
VERIFY THERMISTOR CONNECTION ON CIRCUIT BOARD (OUTLET)

7960-583 C

Figure 3
REMOTE MOUNTING & PIPING

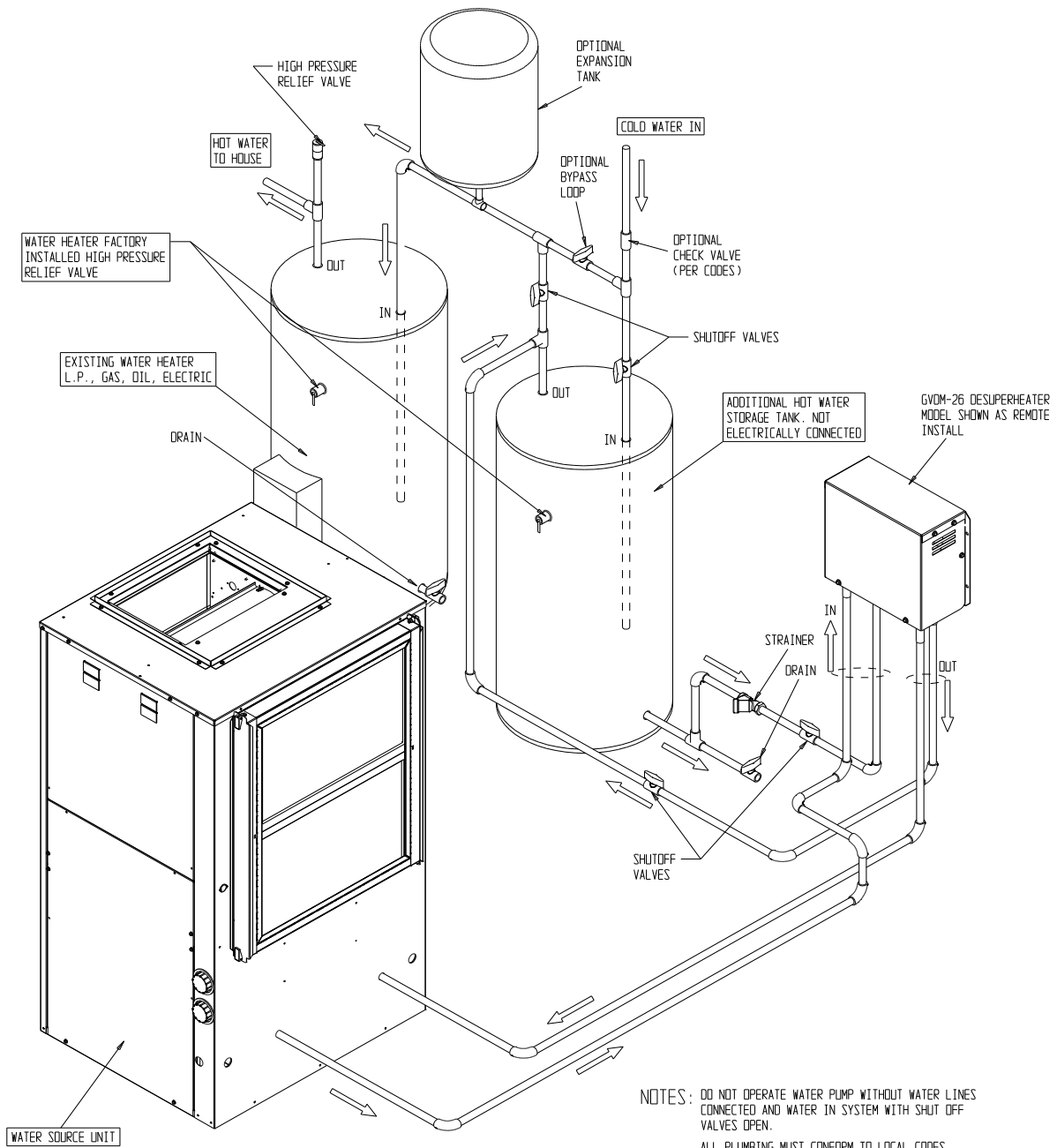

NOTES: DO NOT OPERATE WATER PUMP WITHOUT WATER LINES CONNECTED AND WATER IN SYSTEM WITH SHUT OFF VALVES OPEN.
ALL PLUMBING MUST CONFORM TO LOCAL CODES.
WHEN WATER STORAGE IS INSTALLED IN VERTICAL POSITION, PIPING TO "IN" SIDE OF PUMP MUST BE INSTALLED AT BOTTOM AS SHOWN.

MIS-2652 B

Figure 4
SINGLE TANK SYSTEM

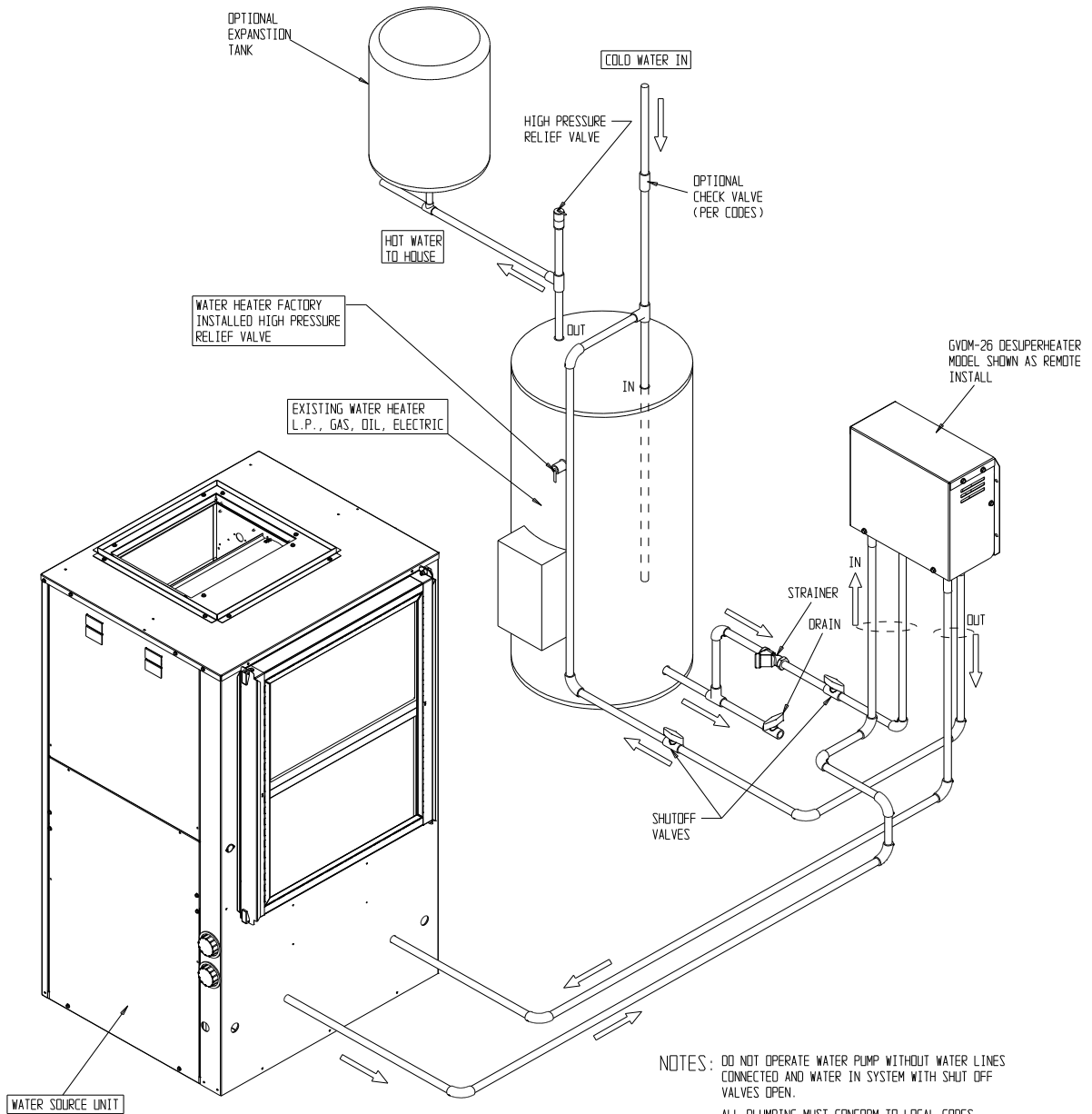

NOTES: DO NOT OPERATE WATER PUMP WITHOUT WATER LINES CONNECTED AND WATER IN SYSTEM WITH SHUT OFF VALVES OPEN.
ALL PLUMBING MUST CONFORM TO LOCAL CODES.
WHEN WATER STORAGE IS INSTALLED IN VERTICAL POSITION, PIPING TO "IN" SIDE OF PUMP MUST BE INSTALLED AT BOTTOM AS SHOWN.

MIS-2653 B

CONTROL BOARD SEQUENCE of OPERATION

The desuperheating control board will make a determination whether or not to energize the pump relay inclusive on the control board.

- A. It will constantly monitor inputs from two temperature sensors, Inlet & Outlet water sensors.
- B. It will constantly monitor the Y signal.
- C. Upon acknowledgment of Y signal, and following two minutes, the control board will energize the pump relay.
- D. After 1½ minutes, based on temperature difference between Outlet & Inlet sensors, and the presence of Y signal, the following will take place:
 - 1.) If temperature difference is greater than 3°F, then the control will continue to energize pump relay.

- 2.) If temperature difference is less than 3°F, then the control will de-energize the pump relay.
- 3.) The control will next wait for 10 minutes before repeating Step #1 (above).

- E. The Over Temperature Limit Switch is placed in series with the line voltage. Therefore, continuity between L of line voltage and L of pump output is forced broken when the Over Temperature Limit Switch opens (see Wiring Diagram).
- F. The 3-amp fuse is put in series with the R connection to the board. Whenever the fuse is blown, the control will lose power and consequently, the relay will disengage.

**Figure 5
THERMISTOR**

TEMPERATURE F vs RESISTANCE R OF TEMPERATURE SENSOR

F	R	F	R
53.0	19374	89.0	7507
52.0	18867	90.0	7334
53.0	18375	91.0	7165
54.0	17989	92.0	7000
55.0	17434	93.0	6840
56.0	16984	94.0	6683
57.0	16547	95.0	6531
58.0	16122	96.0	6383
59.0	15710	97.0	6239
60.0	15310	98.0	6098
61.0	14921	99.0	5961
62.0	14544	100.0	5827
63.0	14177	101.0	5697
64.0	13820	102.0	5570
65.0	13474	103.0	5446
66.0	13137	104.0	5326
67.0	12810	105.0	5208
68.0	12492	106.0	5094
69.0	12183	107.0	4982
70.0	11883	108.0	4873
71.0	11591	109.0	4767
72.0	11307	110.0	4663
73.0	11031	111.0	4562
74.0	10762	112.0	4464
75.0	10501	113.0	4367
76.0	10247	114.0	4274
77.0	10000	115.0	4182
78.0	9760	116.0	4093
79.0	9526	117.0	4006
80.0	9299	118.0	3921
81.0	9077	119.0	3838
82.0	8862	120.0	3757
83.0	8653	121.0	3678
84.0	8449	122.0	3601
85.0	8250	123.0	3526
86.0	8057	124.0	3452
87.0	7869		
88.0	7686		

Figure 6
REPLACEMENT PARTS

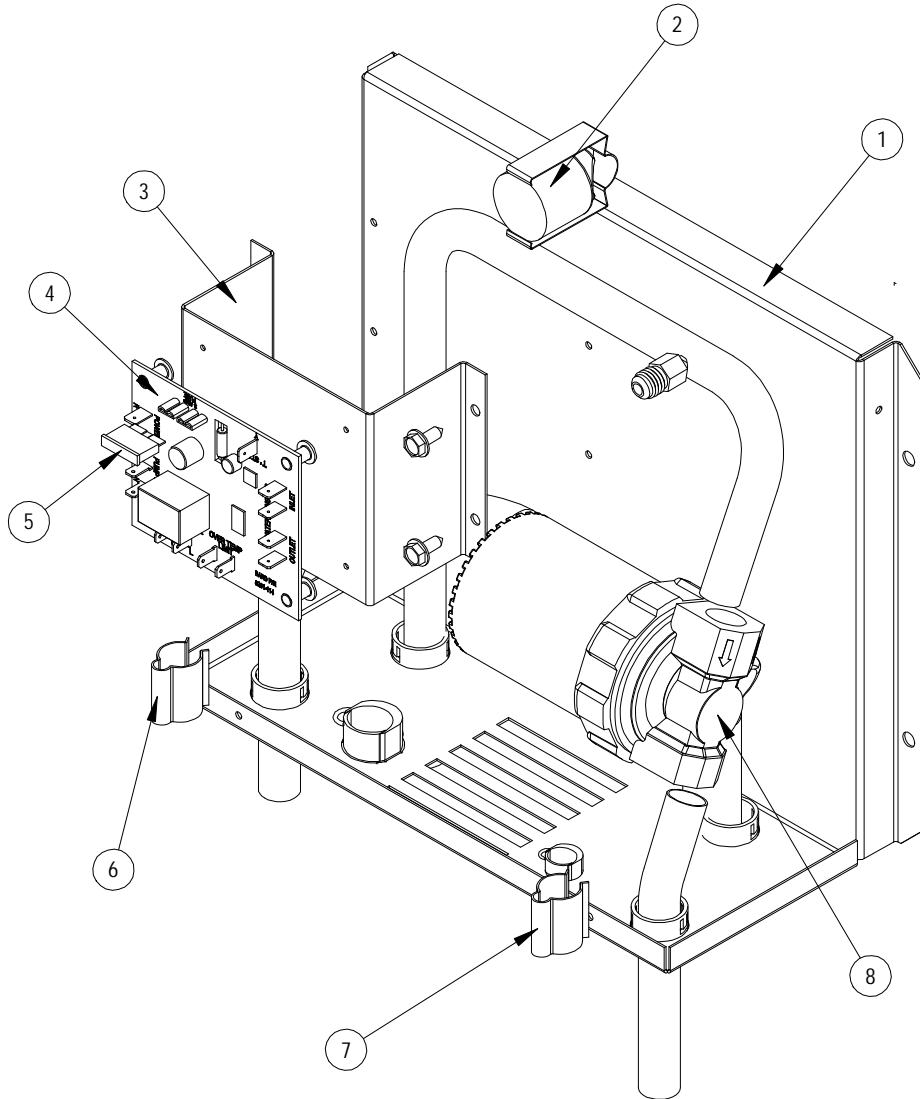

MIS-2669 B

Drawing No.	Part No.	Description
1	S127-374-4	Base
2	8402-182	Water Temperature Limit
3	113-371	Control Board Bracket
4	8201-114	Desuperheater Control Board
5	8614-045	Fuse 3-Amp Violet
6	8408-040	Inlet Thermistor
7	8408-043	Outlet Thermistor
8	8300-010	Circulating Pump
NS	S133-200-4	Cover