

Carlin®

Combustion Technology, Inc.

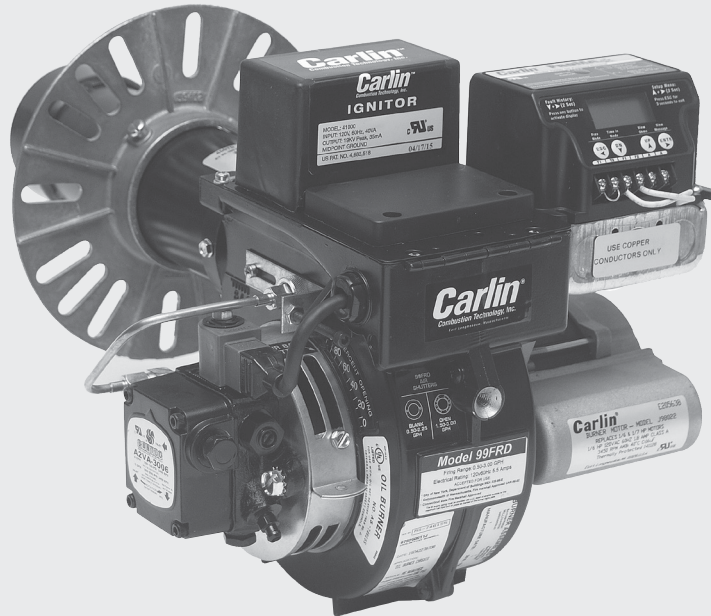

Models **99FRD**
102CRD
EZ-66

Advanced Oil Burners
0.5 to 4.5 GPH

Instruction Manual

Ratings



Input:	99FRD, EZ-66.....	0.50 to 3.00 GPH
	102CRD (2 ⁵ / ₈ " air cone).....	2.00 to 3.50 GPH
	102CRD (3" air cone).....	3.00 to 4.50 GPH
Fuels:	U.S.....	No. 1 or No. 2 Fuel oil
	Canada.....	No. 1 Stove oil or No. 2 Heating oil
Fuel unit:	Suntec
	100 to 150 psig nozzle pressure
Electrical:	Power.....	120V/60 Hz/1-Phase
	Motor.....	Carlin PSC, 1/6 HP, 3450 RPM
	Current	
	99FRD, EZ-66.....	Approx. 5.5 amps
	102CRD.....	Approx. 6.0 amps
Ignition:	Carlin Model 41000 electronic – 19,000 volts
Control:	U.L. Group I or II primary safety control
Agencies:	UL Listed (US and Canada)

WARNING Installer/servicer – Except where specifically stated otherwise, this manual must be used only by a *qualified service technician*. Failure to comply with this or other requirements in this manual could result in severe personal injury, death or substantial property damage.

WARNING User – Refer only to User care and maintenance on back page for information regarding operation of this burner. The burner Instruction Manual is intended only for your service technician. The burner and heat exchanger must be inspected and started at least annually by your service technician.

Contents

PLEASE read this first.....	2
Codes and Standards.....	2
1. 99, EZ-66 & 102 Oil Nozzle Selections.....	3
2. Prepare Site • Assemble Burner • Mount Burner.....	4
3. Prepare Burner.....	9
4. Adjustment and Verification.....	14
5. Annual Start-up and Service.....	15
6. Repair Parts.....	16
7. Maintenance Procedures.....	18
User care and maintenance.....	Rear cover

© Copyright 2015 — Carlin Combustion Technology, Inc.

Carlin Combustion Technology, Inc.

126 Bailey Road
Ph 203-680-9401

North Haven, CT 06473
Fx 203-680-9403

TECH SUPPORT 800-989-2275

carlincombustion.com

PLEASE read this first . . .

Special attention flags

Please pay particular attention to the following when you see them throughout this manual.

DANGER Notifies you of hazards that *WILL* cause severe personal injury, death or substantial property damage.

WARNING Notifies you of hazards that *CAN* cause severe personal injury, death or substantial property damage.

CAUTION Notifies you of hazards that *WILL* or *CAN* cause minor personal injury or property damage.

NOTICE Notifies you of special instructions on installation, operation or maintenance that are important, but are not normally related to injury or property damage hazards.

General information

Burner applications

Follow all instructions in this manual, the primary control data sheet and the appliance manual. Verify the burner is correct for the appliance being used and for all applicable codes/standards.

Damage or shortage claims

The consignee of the shipment must file damage or shortage claims immediately against the transportation company.

When calling or writing about the burner . . .

Please provide us with the UL serial number and burner model number to assist us in locating information. This information can be helpful when troubleshooting or obtaining replacement parts.

WARNING **Should overheating occur:**

- (1) Shut off the oil supply to the burner.
- (2) Do not shut off the control switch to the circulator or blower.

Codes and standards

Certification

99FRD, EZ-66 and 102CRD burners are U.L. listed for the U.S. and Canada, certified to comply with ANSI/UL 296, for use with #1 or #2 heating oil (per standard ASTM D396).

Burner labels list compliance, when required, with special local, state or provincial approvals.

NOTICE Install this burner in accordance with all local codes and authorities having jurisdiction. Regulations of these authorities take precedence over the general instructions provided in this manual.

WARNING Follow the guidelines below to avoid potential severe personal injury, death or substantial property damage.

Installer/service technician . . .

- Read all instructions before proceeding. Perform all procedures, and in the order given to avoid potential of severe personal injury, death or substantial property damage.
- Before leaving the site after startup or service, review the *User's information* page with the user. Make the user aware of all potential hazards and perform the training outlined below.

Train the user . . .

- To properly operate the burner/appliance per this manual and the appliance instructions see *User's information*.
- To keep this manual at or near the burner/appliance for ready access by the user and service technician.
- To contact the service technician or oil dealer if he encounters problems with the burner/appliance.
- To keep the appliance space free of flammable liquids or vapors and other combustible materials.
- Do not use laundry products, paints, varnishes or other chemicals in the room occupied by the burner/appliance.
- To contact the service technician at least annually for startup and burner/appliance service.

When servicing the burner . . .

- Disconnect electrical supply to burner before attempting to service to avoid electrical shock or possible injury from moving parts.
- Burner and appliance components can be extremely hot. Allow all parts to cool before attempting to handle or service to avoid potential of severe burns.

United States installations

Burner/appliance installations in the United States must comply with the latest editions of NFPA 31 (Standard for the Installation of Oil-Burning Equipment), ANSI/NFPA 70 (National Electrical Code), and all applicable local codes.

Canadian installations

Burner/appliance installations in Canada must comply with the latest editions of CSA B139 (Installation Code for Oil Burning Equipment), CSA standard C22, Part 1 (Canadian Electrical Code), and all applicable local codes.

1. 99, EZ-66 & 102 Oil Nozzle Selections *(when appliance data is not available)*

Table 1 Apply the guidelines below to select a nozzle when appliance-specific nozzle data is not available from the manufacturer. See notes at end of table for application tips. 99FRD wrapped-shield air tubes are intended only for approved applications in wet-base combustion chambers.

99FRD/EZ-66 Nozzle specifications — Standard air tubes					99FRD/EZ-66 Nozzle specifications — Wrapped-shield air tubes				
Brand	Spray	Angle & pattern	Nozzle rating, GPH		Brand	Spray	Angle & pattern	Nozzle rating, GPH	
			0.50 to 0.75	0.85 to 3.00				0.50 to 3.00	
Delevan	Hollow	60°A	•	•	Delavan	Hollow	60°A	•	
	Hollow	45°A		•		Hollow	70°A	•	
	Solid	60°B		•	Hago	Hollow	60°H	•	
Hago	Hollow	60°H	•			Hollow	70°H	•	
	Hollow	45°H		•	Monarch	Hollow	60°NS	•	
	Semi-solid	45°SS		•		Hollow	70°NS	•	
	Semi-solid	60°SS	•	•	Steinen	Hollow	60°H	•	
	Solid	45°ES		•		Hollow	70°H	•	
Solid	60°ES		•	Semi-solid		70°Q	•		
Monarch	Hollow	60°NS	•		102CRD Nozzle specifications				
	Semi-solid	45°AR	•	•	Brand	Spray	Angle & pattern	Nozzle rating, GPH	
	Semi-solid	60°AR	•	•				2.00 to 3.50	3.00 to 4.50
	Solid	45°R		•	Delavan	Solid	60°B	•	
	Solid	60°R		•		Solid	70°B	•	
				Solid		80°B	•		
Steinen	Hollow	45°H		•	Hago	Semi-solid	45°SS	•	
	Hollow	60°H	•	•		Semi-solid	60°SS	•	
					Delevan	Solid	70°B		•
					Hago	Hollow	45°H		•
						Semi-solid	45°SS		•

- In general, all the nozzles shown above will burn well. However, in short combustion chambers, solid nozzles are not recommended because the flame may impinge on the back wall.
- If the nozzle selected for a retrofit application results in a smoky fire, you can sometimes determine the best nozzle to use by observing the flame. To do this, slowly cover the air band slots with your fingers while the burner is firing. The flame will begin to smoke in the area where there is more fuel than air. If the smoke begins on the outer edges, try a narrower or more solid nozzle spray pattern. If the flame begins to smoke at the tips, try a wider or more hollow nozzle spray pattern.
- For a packaged appliance application on which the burner has been tested, use the nozzle given in the appliance manufacturer's instructions or supplement for the best results.

2. Prepare Site • Assemble Burner • Mount Burner

Inspect/repair/replace vent system

WARNING

Do not install this burner unless you have verified the entire vent system and the appliance are in good condition and comply with all applicable codes. And ...

- The vent and chimney must be sized and constructed in accordance with all applicable codes.
- Do not install or use an existing manual damper in the breeching (vent connector) or chimney.
- Do not connect the appliance vent connector to a chimney or vent serving a fireplace, incinerator or solid-fuel-burning apparatus.
- In a cold climate, do not vent into a masonry chimney that has one or more sides exposed to the outside. Install a listed stainless steel liner to vent the flue products.
- A defective vent system could result in severe personal injury, death or substantial property damage.

Prepare vent/chimney

- Secure all metal vent joints with screws, following the vent manufacturer's instructions. Seal all joints in the vent system and chimney. Repair masonry chimney lining and repair all mortar joints as needed.
- Install a barometric draft regulator in the vent piping if specified in the appliance manual. (The damper must be located in the same space as the appliance.)
- Provide support for the vent piping. Do not rest the weight of any of the vent piping on the appliance flue outlet.

Combustion/ventilation air openings

Check appliance manual and applicable codes for required sizing/design/ placement of combustion/ventilation air openings. You can use the following general guidelines, taken from NFPA 31, provided they meet all local requirements.

Louvers/screens

- Air opening sizes are always given in free area. This means after deduction for louver obstruction. If you can't find the louver reduction for the grilles used, assume free area is 20% of total for wood louvers, or 60% of total for metal louvers.
- Screens can be no finer than ¼-inch mesh, and must be accessible for cleaning.

Residential installations

Unconfined spaces (at least 7,000 cubic feet per GPH)

- An unconfined space means a room with at least 7,000 cubic feet volume for each GPH input (or 50 cubic feet per MBH) of all appliances in the room. Example: For each 1 GPH oil input, the room must have 7,000 cubic feet (875 square feet with an 8-foot ceiling height.)
- Open basements and crawl spaces are usually large enough, and will generally allow enough air infiltration so special provisions will seldom be required.
- If the building is tightly constructed, you will have to provide outside air openings into the building. The total free area of the openings must be

at least 1 square inch per 5,000 Btuh (28 square inches per GPH) of all appliances in the space.

- See Table 2 for summary.

Confined spaces (less than 7,000 cubic feet per GPH)

- Air taken from inside building only —
 - Provide two openings — one near floor, the other near ceiling. Provide free area of 140 square inches per GPH input. If building is tightly constructed, provide air opening(s) into building providing 30 square inches per GPH as well.
- Air taken from outside —
 - Direct through outside wall or vertical ducts: Provide two openings — one near floor, the other near ceiling. Provide free area of 35 square inches per GPH input.
 - Through horizontal ducts: Provide two openings — one near floor, the other near ceiling. Provide free area of 70 square inches per GPH input.
- Ventilation air from inside/combustion air from outside
 - Size openings to interior to provide 140 square inches free area per GPH input. Size outside air duct to provide 28 square inches free area per GPH.
- See Table 2 for summary.

Table 2 Minimum combustion/ventilation air openings

Source of air	Minimum free area of opening(s)	Total grill area, typical (sq. in.) for firing rates of:					
		1 GPH		2 GPH		3 GPH	
		Wood	Metai	Wood	Metai	Wood	Metai
Residential installations, unconfined spaces (7,000 cu. ft. volume per GPH)							
From inside building, typical construction	No special openings required if natural infiltration is sufficient.						
From inside building, tight construction	1 or more grilles 30 Sq. in./ GPH	150	50	300	100	450	150
Residential installations, confined spaces							
From inside building through interior walls	2 openings, each 140 Sq. in./ GPH	700	234	1400	467	2100	700
From outside building direct through outside wall	2 openings, each 35 Sq. In./ GPH	175	59	350	117	525	175
From outside building through vertical ducts	2 openings, each 35 Sq. In./ GPH	175	59	350	117	525	175
From outside building through horizontal ducts	2 openings, each 70 Sq. In./ GPH	350	117	700	234	1050	350
Ventilation through interior walls, with an opening to outside	2 Int. openings, each 140 Sq. In./ GPH	700	234	1400	467	2100	700
	1 Exterior opening 28 Sq. In./ GPH	140	47	280	94	420	140
Commercial installations							
From outside building direct through adjacent outside wall	One opening through outside wall, providing free area of at least 28 Square inches per GPH input						
Other conditions	Size openings per local codes/jurisdictions						

2. Prepare Site • Assemble Burner • Mount Burner *(continued)*

Combustion/ventilation air checklist

WARNING

The burner may operate successfully under momentary downdraft conditions, but sustained downdraft is unsafe. This can occur with an inadequate or incorrectly installed chimney/vent. It can also occur in rooms/buildings equipped with exhaust fans or unsealed return air ducts. Always check operation of the burner under all conditions to verify vent system operates correctly. You may have to interlock the burner with exhaust fans to shut burner off when fan operates; or provide make-up air to the appliance room sufficient to prevent any negative pressure in the space. Failure to correct downdraft or negative room pressure operation could result in severe personal injury, death or substantial property damage.

- Verify that openings are unobstructed.
- Verify that appliance space and air source spaces are free of:
 - Gasoline or other flammable liquids or vapors.
 - Combustible materials.
 - Air contaminants and chemicals, such as laundry products, paint, thinner, varnish, etc.
- Confirm with the building owner that the area will be kept free of these materials at all times and that air openings will be kept unobstructed.

Verify clearances

Verify that the burner/appliance will maintain all clearances from combustible construction and clearances for service/maintenance as required in the appliance manual and applicable codes.

Verify that the vent system components maintain all necessary clearances to combustible construction, including the correct design of thimbles and insulation where penetrating combustible walls.

Verify combustion chamber

Chamber dimensions and construction

- If retrofitting the burner to an appliance, install the burner in accordance with the appliance instruction manual, when available. If no specific application data is available from the appliance manufacturer, read the guidelines in Figure 1, page 6, to check whether the burner is likely to work acceptably in the application.

- Illustrations A to F in Figure 1 show different chamber configurations with and without refractory linings. The chamber dimensions listed in Figure 1 depend on whether the chamber is lined or water-backed.
- Do not attempt to fire the burner in a chamber with dimensions smaller than shown in Figure 1, page 6, unless the application has been specifically tested and listed by the appliance manufacturer and/or Carlin.
- Chambers with dimensions larger than shown in Figure 1, page 6, should not have much effect on combustion/performance.

General guidelines

- Clean all appliance flues and heating surfaces thoroughly, removing all soot and scale.
- Seal all joints and gaps using furnace cement to prevent excess air infiltration.

CAUTION

The 99FRD/EZ-66 wrapped-shield air tube must be used only in wet-base combustion chamber applications – unless specified by Carlin.

Using chamber linings and lightweight chambers

- When using refractory liners or lightweight chambers, use insulating-type refractory rated 2300°F minimum.
- You must install a target wall liner if flame length is close to the length of the chamber.
- Use a floor liner when possible. The floor liner will improve firing in most applications. Extend floor liner 3 to 4 inches up side wall.
- Target wall liners — Corbel the top of target wall liners 1½ to 2½ inches deep and extend at least 3 to 4 inches above the center of the flame.
- Use pre-formed chamber liners when available.
- For firing rates below 0.75 GPH, it is best to apply in a refractory-lined or stainless tube (designed for application) chamber. Lining the floor and target wall of the chamber with lightweight insulating refractory will accomplish the same.
- When conversion firing coal-fired units, install a combustion chamber in the ashpit area, or fill ashpit with sand up to 2 inches above the “mud ring” of a boiler (firing through the door). Install a lightweight refractory liner on the target wall as in Figure 1F, page 6. Make sure the minimum dimensions comply with those for Figure 1F.

2. Prepare Site • Assemble Burner • Mount Burner *(continued)*

Figure 1 99FRD, EZ-66 and 102CRD Minimum combustion chamber dimensions (all dimensions in inches)

Firing rate GPH	LD	LT	LW	W	DV	CD	CW	H	F
	Lined	Target liner	Unlined	Note 3	Note 5	Lined	Unlined		
99FRD/EZ-66									
0.50	7	Line floor and target wall or use refractory chamber		6	7	3	NR	8	NR
0.65	7.5		7	7.5	3.5	9			
0.75	8		7	8	3.5	9			
0.85		10-11	12	7	8.5	3.5	4	9	5
1.00	10	11-12	13	8	9	4	4.5	10	6
1.10	11	12-13	14	8	9.5	4	4.5	10	6
1.25									
1.35									
1.50									
1.65									
1.75									
2.00									
2.25									
2.50									
2.75									
3.00									
102CRD with 2% air cone									
	14	14	17	15	13	6.5	6.5	15	8
	15	15	18.5	15	13.5	6.5	6.5	15	8
	16	16	19.5	15.5	14.0	6.5	6.5	15.5	8
	17.5	17.5	21	15.5	15.5	6.5	6.5	15.5	8
	18.5	18.5	22.5	15.5	16.5	7	7	15.5	8.5
	20	20	24	16	17.5	7	7	16	8.5
	21	21	25	16	18.5	7	7	16	8.5
with 3" air cone									
	25	25	29	12	23	5	5	12	6.5
	26	26	30	13	24	5.5	5.5	13	7
	27	27	31	13.5	24	6	6	13.5	7.5
	28	28	32.5	14	25	6	6	14	7.5
4.00	29	29	34	14.5	26	7	7	14.5	8.5
4.25	30	30	35	15.5	27	7	7	15.5	8.5
4.50	31	31	36	17	28	7.5	7.5	17	9

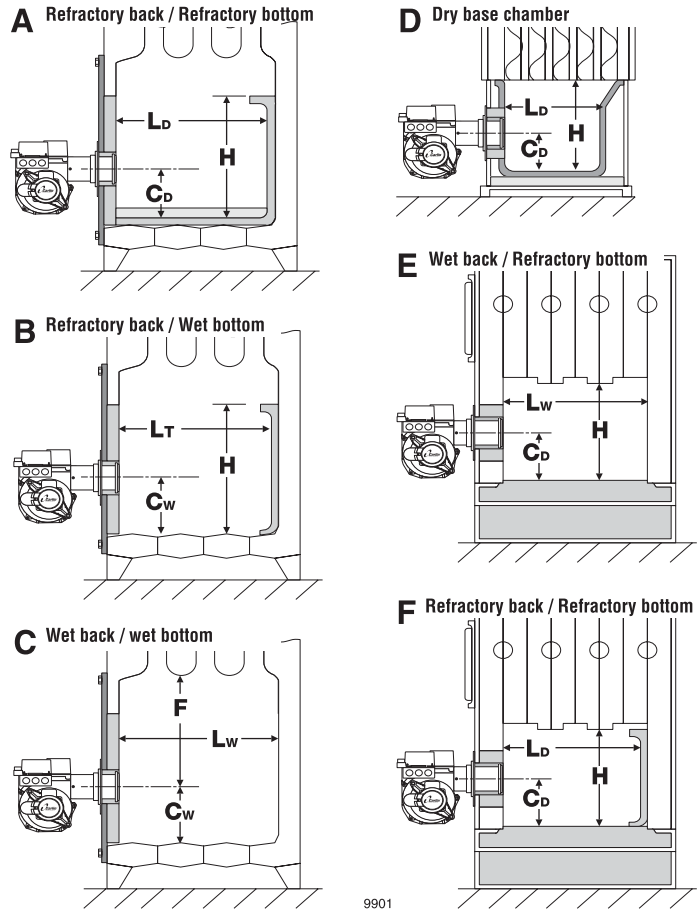

Chamber configurations

- A Chamber with water-backed floor and target wall, with refractory linings on floor and target wall.
- B Chamber with water-backed floor and target wall, with refractory lining on target wall only.
- C Chamber with water-backed floor and target wall, without refractory linings.
- D Refractory chamber, no water-backed surfaces (dry base design).
- E Chamber with refractory floor and water-backed target wall (*without* target refractory lining).
- F Chamber with refractory floor and water-backed target wall (*with* target refractory lining).

Notes for dimension table

- 1 Some tested appliances operate well with dimensions other than shown below.
2. Generally, applications should be acceptable with dimensions larger than listed.
3. Horizontal cylinder chambers should have a diameter at least as large as the minimum width listed. For steel cylinder chambers, increase this dimension by from 1 to 4 inches.
4. Wing walls are not recommended. Corbels can be beneficial to heat distribution in some applications.
5. DV is the minimum diameter for vertical cylindrical chambers (refractory or refractory-lined chambers only).

2. Prepare Site • Assemble Burner • Mount Burner *(continued)*

Inspect burner and components

- Check the air tube length. Verify the usable length of the tube UTL will be long enough (see "Mount burner in appliance").
- Visually inspect all burner components and wiring.
- Verify that wiring is intact and leads are securely connected.
- Verify that all burner components are in good condition.

WARNING

Do not install or operate the burner if any component is damaged or if burner does not comply with the specifications of Table 1, page 3, and other guidelines of this manual and the appliance manual.

Welded-flange burners

1. Verify the bolt pattern on the appliance chamber matches the flange pattern.
2. Verify the insertion depth (UTL) matches the depth of the appliance opening (so the end of the air tube is flush with, or slightly short of, the inside surface of the combustion chamber).

Assemble burner (when required)

Universal (adjustable) flange burners

1. Verify the flange mounting slots line up with the appliance bolts. See Figure 2.
2. Slip the adjustable flange onto the air tube.
3. Measure the distance from the inside of the combustion chamber to the outside of the appliance mounting plate.
4. Position the universal flange at this distance from the end of the air tube.
5. Tighten the locking screws finger tight.
6. Insert the air tube/flange assembly into the appliance opening and level the air tube with a spirit level. Adjust flange if needed.
7. The end of the air tube should be flush, or almost flush, with the inside of the combustion chamber wall.
8. Verify the air tube is level and inserted the correct depth. Adjust if necessary. Then tighten the flange locking screws securely.
9. Remove the flange/air tube assembly from the opening.

Pedestal mount burners

1. Check the diameter of the appliance opening. If larger than 4½ inches, rebuild the opening so the open is reduced to 4½ inches maximum.
2. Insert the air tube into the appliance opening as in Figure 3. Do not attach air tube to housing yet.
3. Slide the tube in until the end of the tube is flush with, or up to ¼ inch short of, the inside of the combustion chamber.

Figure 2 Universal flange mounting dimensions

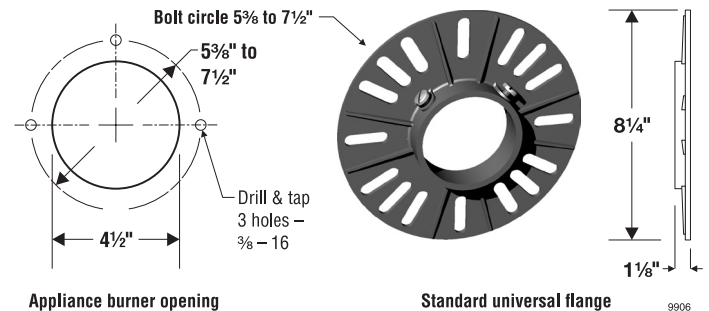
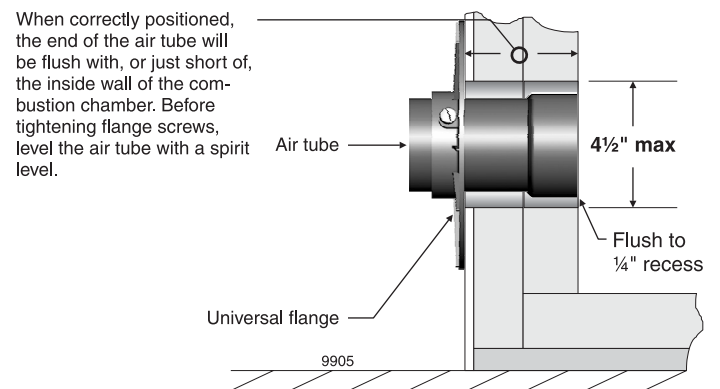

Figure 3 Mark insertion depth on air tube when using universal flange mounting



4. Level the air tube using a spirit level.
5. Mark the air tube position with a pen or pencil around the circumference of the tube.
6. Remove air tube from the opening.

NOTICE — 99FRD/EZ-66 burners firing above 2.25 GPH

1. 99FRD, EZ-66 burners are shipped with the blank air shutter (behind fuel unit) installed. This shutter is suitable only for firing rates up to 2.25 GPH.
2. For firing rates over 2.25 GPH, obtain an open type air shutter from your Carlin dealer. Remove the blank shutter and replace with the open shutter.
3. The optional open air shutter is suitable for firing rates from 1.50 to 3.00 GPH.
4. To change air shutters, remove the burner fuel unit. (The fuel unit holds the shutter in place.) Install the correct shutter and replace the fuel unit.

2. Prepare Site • Assemble Burner • Mount Burner *(continued)*

Attach air tube to housing

1. See Figure 4. Remove air tube locking screws on the front of the burner chassis.
2. Open ignitor cover plate by loosening the hold-down tabs and swinging them away.
3. Spread the housing slightly using a flat screwdriver between the two halves of the housing on top at the air tube collar.
4. Insert the air tube into the housing, make sure the tube is inserted completely, butting against the air tube collar ledge. If necessary, tap on the end of the air tube with a block of wood until properly seated.
5. When using 99FRD/EZ-66 wrapped-shield air tube or 102 CRD “B” style air tube, locate the drip hole in the air cone. Rotate the air tube so the drip hole is at the bottom before pressing into place.
6. Replace and tighten air tube locking screws.

Figure 4 Attaching air tube to burner chassis

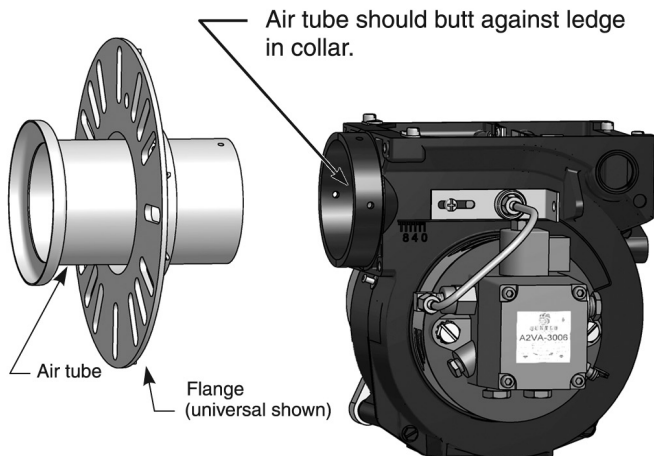

2. Insert burner into appliance.
3. Verify burner is seated level and straight. Adjust flange slightly if necessary.
4. Secure flange to appliance with hardware supplied with appliance.

Pedestal-mounted burner

1. Assemble pedestal to the bottom of the burner by tightening the two ¼-20 slotted cap screws against the front feet of the housing. See Figure 5. Install the four adjusting legs (3/8-16 x 3" hex-head cap screws).
2. Adjust the pedestal legs so the air tube is level and the center of the tube is at the same height as the center of the appliance opening.
3. Tighten the pedestal leg jam nuts to lock legs in place.
4. Insert the burner/air tube into the appliance opening until pen/pencil line is even with appliance front (so end of air tube is flush with, or slightly short of, the inside of the chamber).
5. Seal the space around the air tube with furnace cement or equivalent (Figure 6).

Figure 5 Attaching burner to pedestal (when used)

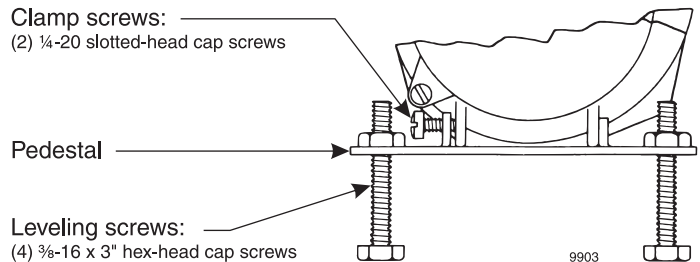

Mount burner in appliance

Welded flange-mounted burner

1. Place gasket over burner air tube and insert burner into appliance opening. Secure in place with hardware supplied with appliance.

WARNING

Universal flange or pedestal mount — these insertion methods are intended only for negative overfire pressure. For pressurized firing, you must obtain a burner with a welded flange, designed for use with the specific appliance. Failure to comply could result in severe personal injury, death or substantial property damage.

Universal flange-mounted burner

1. Place gasket over burner air tube.

Figure 6 Seal opening around burner air tube when pedestal mounting (burner shown with tube attached to housing and installed)

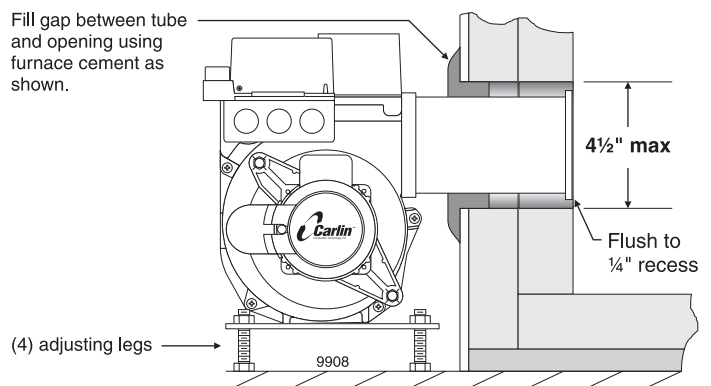

3. Prepare Burner

Removing/installing head assembly

WARNING Use care when handling burner components after the burner has been firing. Components can be hot and could cause severe personal injury.

You will need to remove the combustion head assembly for inspection of the assembly, replacement of the oil nozzle or adjustment of electrodes. To remove the assembly:

1. Loosen, and then rotate the two screw clamps securing the ignitor in place. Swing the ignitor plate open.
2. See Figure 7. Remove the blower shield by loosening the retaining screw on its front edge if needed for easier removal or insertion of the combustion head assembly.
3. Unscrew the oil line fitting and thumb nut at the burner housing.
4. Pull the threaded end of the oil tube into the blower housing.
5. See Figure 7. Rotate the combustion head assembly 180° so the electrodes are upside down. This places the electrode insulators out of the way for easy removal.
6. Remove the combustion head assembly by pulling the assembly up and out of the housing.
7. Handle the assembly with care to avoid bending/moving the electrodes, or damaging the electrode ceramic insulators.
8. Inspect the gasket on the bottom of the ignitor plate. The gasket prevents air from escaping from the housing. Replace the gasket if not in good condition.
9. Inspect the ignitor contact clips. Clean or replace if necessary to ensure reliable contact with the electrodes.

Figure 7 Removing/inserting combustion head assembly

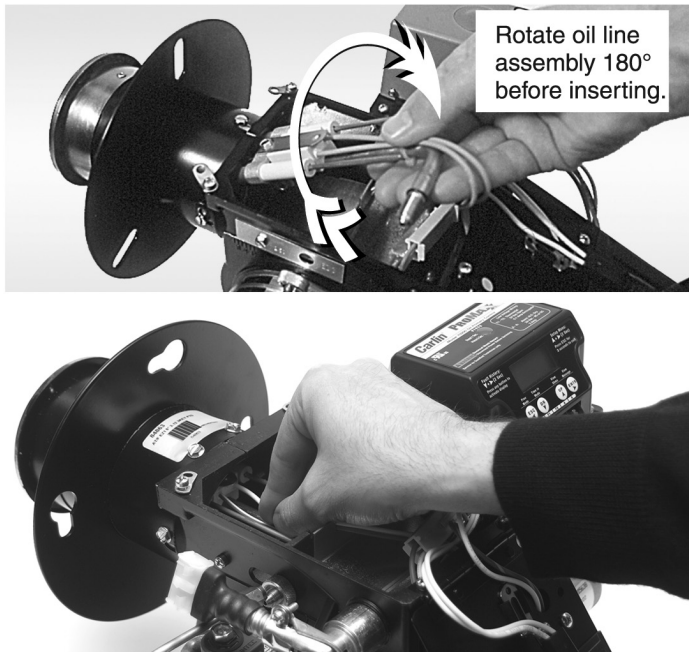

To replace the combustion head assembly, reverse the sequence.

- Remember to put the assembly in upside down, so the electrode insulators are out of the way. Remove, then replace, the blower shield if necessary for easier removal/insertion of the assembly.
- See Figure 8. For 99FRD or EZ-66 burners, you will have to lift the end of the assembly to guide it through the throttle at the end of the air tube. DO NOT FORCE.

CAUTION Use care when tightening the oil line fitting to oil tube extension. Tighten securely, but do not cross-thread or over-tighten.

Figure 8 Inserting combustion head assembly

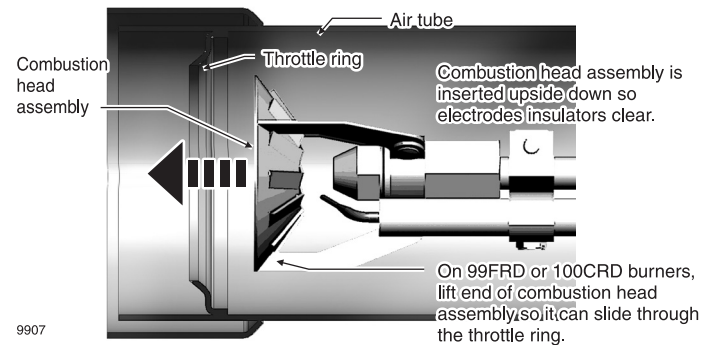

Install nozzle/check electrodes

1. Loosen the clamp screw on the retention ring assembly (see Figure 10, page 10). Slide the retention ring assembly off of the nozzle adapter. Then loosen electrodes to rotate out of the way.
2. Install and tighten the nozzle shown in Table 1, page 3, for retrofit applications. Install the nozzle given in the appliance manual when application information for the 99FRD, EZ-66 and 102CRD oil burner is given.
3. Hold the nozzle adapter securely when removing or replacing the nozzle (Figure 9). Take care not to damage the electrode insulators or to bend the electrodes in the process.

Figure 9 Carefully support the nozzle adapter when installing or removing nozzle

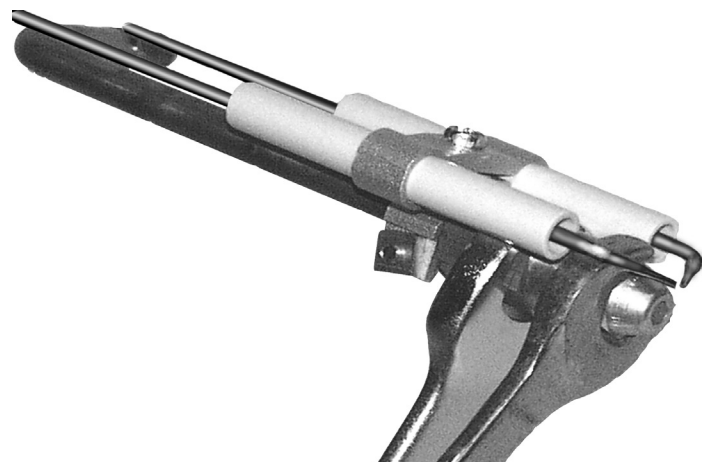

3. Prepare Burner *(continued)*

Figure 10 Combustion head/nozzle/electrode settings

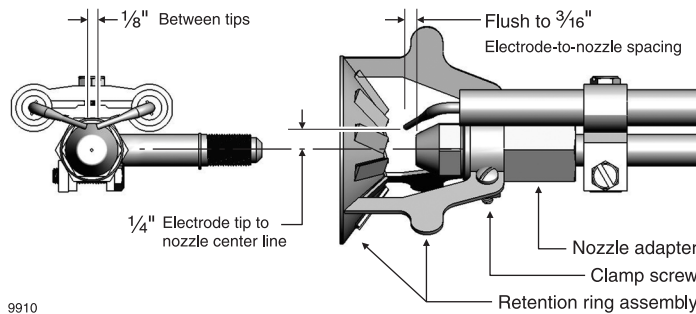

9910

WARNING Inspect the nozzle adapter before replacing the nozzle. If the threads have been damaged or show score marks, replace the nozzle line/adaptor assembly.

4. Replace the retention ring assembly by slipping one of the riveted arms through the gap between the electrode tips. Align this arm straight up, with the ring clamp firmly against the nozzle adapter shoulder (see Figure 10). Then tighten the clamping screw.
5. Reposition and check the electrode settings. Position the electrodes as shown in Figure 10. These settings are critical in ensuring a reliable ignition. Once the electrodes are set, check all clamps to be sure they are securely tightened.
6. Insert the combustion head/nozzle assembly in the burner.

Check zero position *(99FRD only)*

1. See Figures 11, 12 and 13. Loosen the oil line thumb nut and adjusting slide locking screw. Use a $\frac{5}{32}$ " Allen wrench to rotate the adjusting screw until the lead edge of the slide aligns to "0" on the scale. The retention ring should be flush, or nearly flush, with the edge of the throttling ring.
2. If the retention ring is not close to flush with the throttle ring, make sure the air tube is completely inserted into the housing collar and the retention ring clamp is firmly against the nozzle adapter shoulder.

Figure 11 Check zero position — 99FRD only

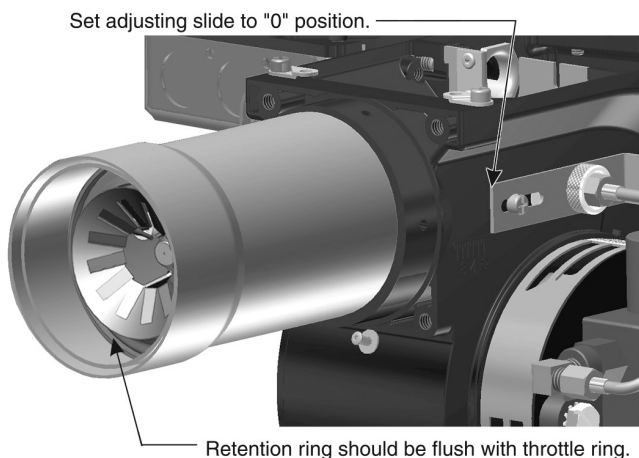
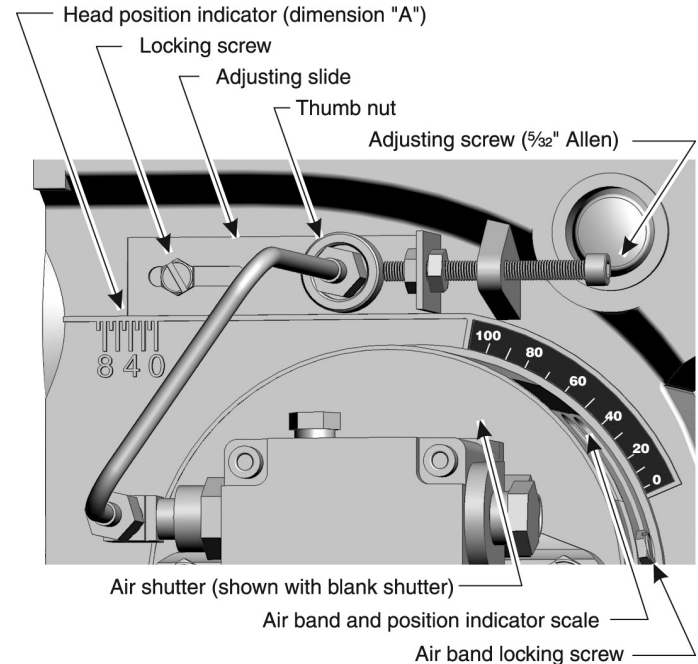

Figure 12 Combustion head and air band adjustments



Set initial burner air settings

Combustion head

1. The combustion head adjusting slide controls the spacing between the retention ring and throttle ring (or air cone), regulating how much air passes around the retention ring.
2. Loosen the oil line thumb nut and adjusting slide locking screw. Use a $\frac{5}{32}$ " Allen wrench to rotate the adjusting screw until the lead edge of the slide aligns to the number given in Table 3, page 11. Lock in place by first tightening the oil line thumbnut, then tightening the locking screw.

Air shutter

1. The air shutter is fixed for all 99FRD, EZ-66 and 102CRD burners. See page 7 for the correct air shutter type. (Some 102CRD burners may be equipped with 3-slot air shutters.)

Air band

1. The air band is marked in percent opening. Loosen the air band locking screw and move the air band until the pointer lines up with the percent opening given in Table 3, page 11.

Final adjustments

1. The burner is now adjusted to the approximate air settings for the firing rate chosen. When you check combustion with instruments during start-up or servicing, you may have to adjust the head slightly to achieve the desired efficiency. See "Adjust burner using test instruments," page 22. (Note that pressure overfire will reduce air flow, requiring more air opening.)

3. Prepare Burner *(continued)*

Figure 13 Combustion head/air tube combinations, typical

99FRD/EZ-66 Standard air tube

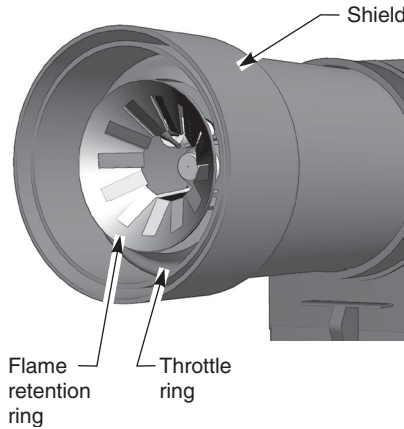

99FRD/EZ-66 Wrapped-shield air tube

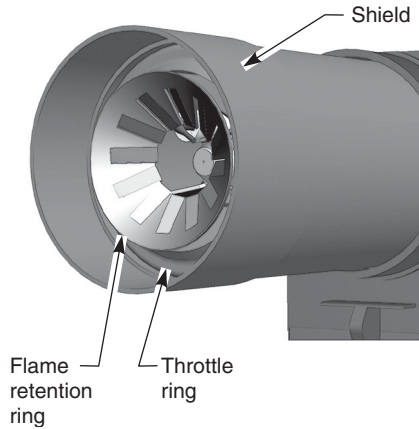

102CRD air tube

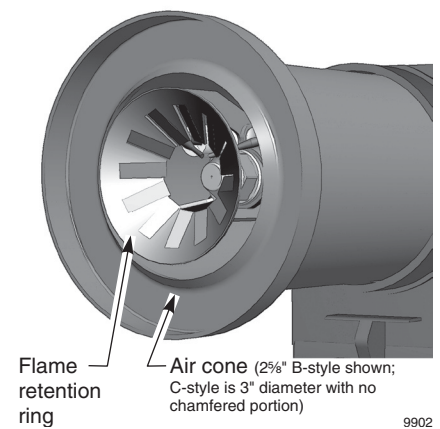

9902

Table 3 Approximate air band and combustion head settings

Firing rate	99FRD/EZ-66 (standard air tube)				99FRD/EZ-66 (wrapped-shield air tube)				Firing rate
	Blank air shutter		Open air shutter		Blank air shutter		Open air shutter		
	Air band	Head	Air band	Head	Air band	Head	Air band	Head	
GPH @ 100 PSI	% open	Dim. "A"	% open	Dim. "A"	% open	Dim. "A"	% open	Dim. "A"	GPH @ 100 PSI
0.50	15-20	0	—	—	15	0	—	—	0.50
0.60	15-20	0	—	—	15-20	0	—	—	0.60
0.65	15-20	0	—	—	20	0	—	—	0.65
0.75	20	0-1	—	—	25	1	—	—	0.75
0.85	20-25	0-1	—	—	30	1-2	—	—	0.85
1.00	30	1-2	—	—	40	2	—	—	1.00
1.10	35	1-2	—	—	40	2-3	—	—	1.10
1.20	45	1-2	—	—	45	3	—	—	1.20
1.25	50	1-2	—	—	50	3	—	—	1.25
1.35	55	2	—	—	55	3-4	—	—	1.35
1.50	70	2	15	2	60	4	0	4	1.50
1.65	75	2-3	20	2-3	65	5	5	4-5	1.65
1.75	80	3	25	3	70	5	10	5	1.75
2.00	100	4-5	70	4	100	6	45	6	2.00
2.25	100	6	100	5	100	8	65	7	2.25
2.50	—	—	100	6-7	—	—	100	9	2.50
2.75	—	—	100	8	—	—	100	11	2.75
3.00	—	—	100	10	—	—	—	—	3.00

	102CRD (2 5/8" air cone — "B"-style air tube)			102CRD (3" air cone — "C"-style air tube)			GPH @ 100 PSI
	Head	Air band	Air shutter	Head	Air band	Air shutter	
	Dimension "A"	% open	Type	Dimension "A"	% open	Type	
2.00	2	25	Open (4-slot)	—	—	—	2.00
2.25	4	100	Open (4-slot)	—	—	—	2.25
2.50	5	100	Open (4-slot)	—	—	—	2.50
2.75	7	100	Open (4-slot)	—	—	—	2.75
3.00	9	100	Open (4-slot)	0	50	Open (4-slot)	3.00
3.25	10	100	Open (4-slot)	1	65	Open (4-slot)	3.25
3.50	11	100	Open (4-slot)	2	80	Open (4-slot)	3.50
3.75	—	—	—	4	90	Open (4-slot)	3.75
4.00	—	—	—	6	100	Open (4-slot)	4.00
4.25	—	—	—	9	100	Open (4-slot)	4.25
4.50	—	—	—	11	100	Open (4-slot)	4.50

3. Prepare Burner *(continued)*

Inspect/install fuel supply

CAUTION Inspect the oil supply system. Ensure that the fuel lines are correctly sized and installed and that the fuel flow is unobstructed, the oil tank is clean and only # 1 or # 2 heating oil are supplied. Failure to supply a reliable oil flow could result in loss of heat and potential severe equipment damage.

General guidelines:

- When installing oil lines, use continuous runs of heavy-wall copper tubing if possible.
- Check fuel unit (oil pump) data sheet for recommended line sizing, lift limitations and maximum length.
- Check all connections and joints to ensure they are air-tight.
- Use flare fittings. Do NOT use compression fittings.
- Never use pipe sealing tape. Fragments can break off and plug fuel line components.
- Install a shut-off valve at the tank and one near the burner. (Use fusible handle design valves when possible or when required by codes.)
- Install a large capacity fuel filter (rated for 50 microns or less) near the burner.

Fuel unit bypass plug

WARNING The fuel unit is shipped with its bypass plug not installed, intended for a one-line oil system. Install the bypass plug only if connecting to a two-line oil system. Operating with the plug in place on a one-line system will damage the fuel unit and could lead to oil leakage and fire hazard.

WARNING If the fuel line or fuel supply is above burner, never exceed 3 PSIG pressure at the fuel unit inlet. Install a suitable OSV to reduce the pressure. Operating the fuel unit with higher inlet pressure could result in fuel unit seal damage, oil leakage and potential fire hazard.

Nozzle line heater

- Oil burners often operate in spaces where temperatures tend to be cool, typically 60°F or lower. Cool oil has higher viscosity, which can affect atomization, ignition, combustion and fuel consumption. The nozzle line heater avoids this problem by heating the nozzle line oil to between 120°F and 130°F, resulting in smoother ignition and improved combustion.

- The nozzle line heater needs power when the burner is in standby (no call for heat from the appliance). Make sure the nozzle line heater is powered directly from the 120 VAC HOT line, not through the appliance operating control circuit. The nozzle line heater wiring should be shown on the wiring diagram supplied with the appliance/burner unit.
- The nozzle line heater is supplied with an electrical disconnect harness, allowing removal of the combustion head assembly without disconnecting wires. Position the heater harness disconnect in the rear of the blower housing, above the blower access cover. The wire leads to the disconnect route through the side of the housing into the junction box.

NOTICE When first starting the burner, or after the service switch has been off for some time, the heater requires about 15 minutes to bring the oil to operating temperature.

One-line fuel system requirements

See Figure 14. The standard burner fuel unit is a single-stage, 3450-RPM oil pump. Apply this fuel unit only on one-line systems where the fuel supply is on the same level with, or higher than, the burner. This ensures oil flow by gravity. Also make sure the total lift does not exceed 8 feet (height difference from bottom of oil tank to fuel unit). For other conditions, you must provide a two-line fuel system. You may also have to change the fuel unit to a two-stage type.

Figure 14 One-line fuel system

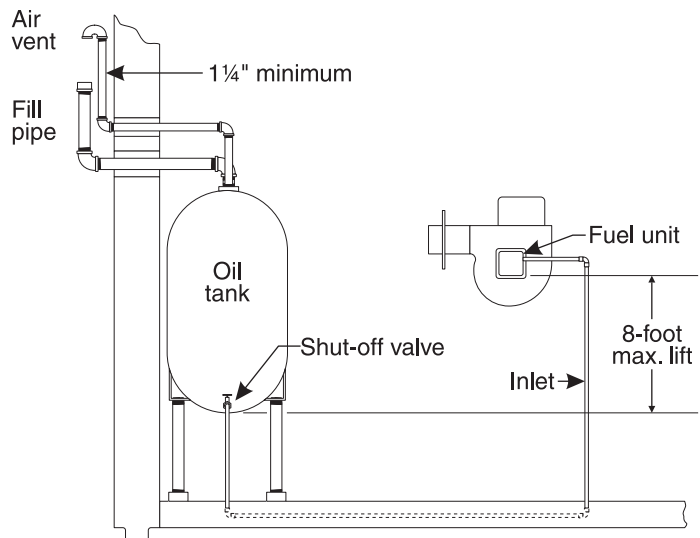

3. Prepare Burner *(continued)*

Two-line fuel system requirements

See Figure 15 and Table 4. Use Table 4 only for burners equipped with Suntec fuel units. For burners using other fuel units, read the fuel unit manufacturer's data sheet to determine maximum lengths and lifts.

The standard burner fuel unit is a single-stage, 3450-RPM oil pump. Use this fuel unit only on two-line oil systems that do not exceed the total tubing lengths allowed in Table 4 (for Suntec fuel units only). For longer systems (or where lift exceeds 10 feet), replace the one-stage fuel unit with a two-stage unit.

Always size fuel lines using an oil flow rate based on the fuel unit gearset capacity, not the burner firing rate. See fuel unit data sheet for information.

NOTICE Install the fuel unit bypass plug when connecting to a two-line system. The plug is shipped in a bag attached to the fuel unit, along with a fuel unit data sheet.

Table 4 Two-line fuel system maximum lengths for 3/8" and 1/2" OD copper tubing distribution. Use only for burners equipped with Suntec fuel units. See fuel unit data sheet for any other fuel unit.

Lift (feet)	Max. total length of tubing, feet (including both horizontal and vertical)			
	Single-stage fuel unit		Two-stage fuel unit	
	3/8" tubing	1/2" tubing	3/8" tubing	1/2" tubing
0	84	100	93	100
2	73	100	85	100
4	63	100	77	100
6	52	100	69	100
8	42	100	60	100
10	31	100	52	100
12	NOT recommended — use two-stage fuel unit		44	100
14			36	100
16			27	100
18			-	76

Figure 15 Two-line fuel system

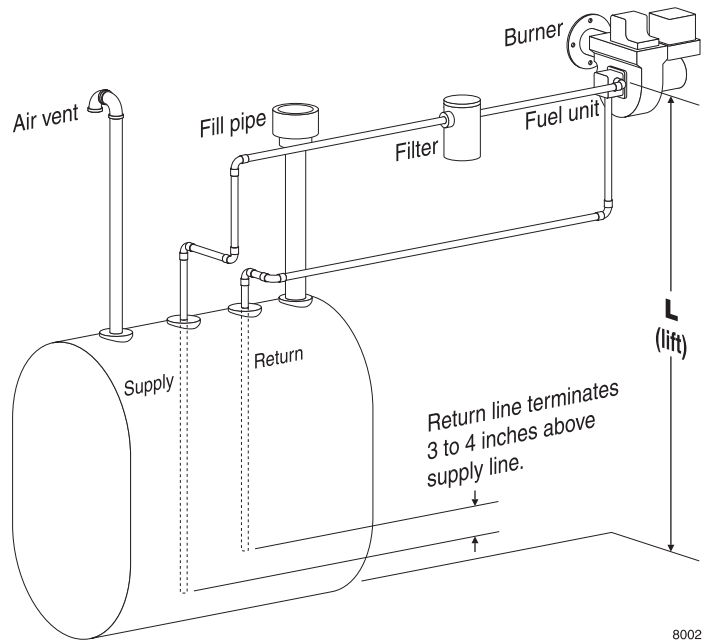

Perform checkout procedures

Verify before starting burner:

- WARNING** Should overheating or an emergency occur, immediately:
- Shut off oil supply line valve.
 - Under some circumstances power should remain on for water pumps or blowers. Determine proper response before attempting start-up.
 - If burner fails ignition on several attempts, use burner blower to purge appliance chamber before restart.

Checklist

- Burner/appliance installed per appliance instruction manual?
- Burner nozzle and head positioning bar verified against Table 1, page 3, or appliance manufacturer's instructions?
- Burner/appliance installed per all applicable codes?
- Installation site has adequate combustion/ventilation air openings and vent system?
- Fuel supply line in good condition and sized/designed correctly?
- Oil tank has oil and oil line valves are open.
- Wiring installed per burner/appliance instructions?
- Burner, appliance and all components inspected and in good condition?

4. Adjustment and Verification

Adjust burner using test instruments

1. Operate burner for 15 minutes before making final adjustments using test equipment.
2. Check for leaks in fuel piping.

WARNING Inspect fuel piping system for leaks. Repair any leaks to avoid fire hazard from oil leakage or combustion problems due to air infiltration into oil.

3. Inspect flame
 - Look at flame through appliance combustion chamber observation port. The flame should be well-defined and should not impinge on any appliance surface. (If you make air changes later, inspect the flame again.)

WARNING Do not attempt to confirm combustion simply by inspecting the flame visually. You must use combustion test instruments. Failure to properly verify/adjust combustion could allow unsafe operation of the burner, resulting in severe personal injury, death or substantial property damage.

1. Insert test probe into vent sample opening to sample flue products.
2. With the 99FRD, EZ-66 or 102CRD burner equipped with the correct oil nozzle, head setting and air band setting, the flue products will usually contain between 11½% and 12½% CO₂ (5.9% and 3.8% O₂) and zero (Bacharach) smoke.
3. Use combustion test equipment to verify that burner is properly set up for your installation, within the range listed in Table 3. Appliances with positive pressure in the chamber may require a wider air opening. See appliance instructions for details. Verify/adjust settings by testing with instruments.
 - a. Check smoke. It should be zero on the Bacharach scale.
 - b. Set the appliance flue damper or barometric draft regulator so the draft or pressure in the vent complies with the appliance manufacturer's instructions.

WARNING Heating units designed for natural draft operation are normally set for a slightly negative pressure, usually -0.01 to -0.02 inches w.c. draft at the combustion chamber test port. Appliances designed for forced draft (positive pressure in the chamber) must be air-tight to prevent exfiltration of harmful combustion products. Failure to properly set draft for the appliance could result in severe personal injury or death.

- c. Check percent of CO₂ (or O₂). Fine tune the burner, if necessary, by slightly adjusting the head position for more or less air.
- d. Recheck smoke (should be zero) and flue or chamber pressure/draft (adjust if necessary and retest).

WARNING All installations should be checked after one to two weeks of operation to ensure the appliance/burner units are operating correctly.

Firing against positive overfire pressure

1. Burner rating maximum inputs are based on operation with zero to slightly negative pressure overfire, typically 0.01 to 0.03 inches w.c.
2. When a burner is applied to an appliance that operates with a higher pressure overfire, the maximum firing rate decreases because the maximum available air flow from the burner blower decreases.
3. Read the graph below in Figure 16 to find the maximum burner firing rate at positive overfire pressures.

WARNING Do not apply a 99FRD, EZ-66 or 102CRD burner at a pressure higher than listed in Figure 16 unless the application has been factory pretested.

Figure 16 Maximum firing rate decreases as overfire pressure increases

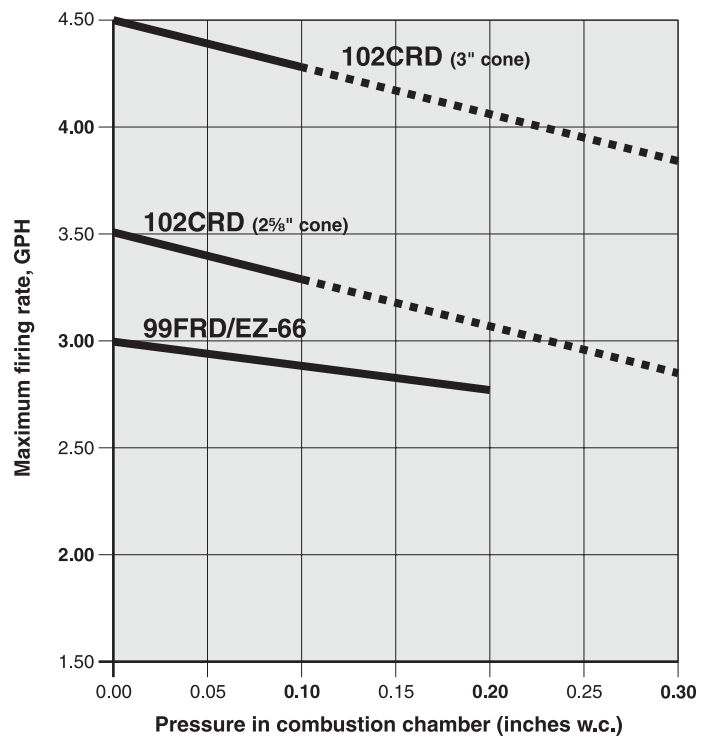

9916

99FRD/EZ-66

(Do not fire at overfire pressure greater than 0.20 inches w.c. without factory pretesting.)

102CRD

(Do not fire at overfire pressure greater than 0.10 inches w.c. without factory pretesting.)

4. Adjustment and Verification *(cont.)*

Verify burner/appliance operation

Check burner/appliance/controls operation

- Test operating and limit controls on appliance as specified in appliance instructions.
- Check operation of the primary control by forcing lockout to occur. For primary controls that enter latch-up after multiple lockouts, force latch-up to occur as well. Reset primary control per control data sheet instructions after each test.
- Start and stop the burner several times, allowing the primary control to sequence through normal operation. Verify correct operation of burner and primary control throughout.

Verify vent system operation

- Verify vent is operating correctly and flue products are properly exhausted from building. If the building contains any exhaust fans or conditions that could affect vent performance, check burner/appliance/vent operation with exhaust fans (or other conditions) operating.

Combustion/ventilation air

- Verify combustion/ventilation air openings are not/will not be obstructed.
- Verify air opening louvers are full open.
- If louvers are motor-operated, verify motor and end switch are interlocked with appliance/burner wiring to prevent operation of the burner if the air louvers are not fully opened.

Prepare burner for normal operation

- Cycle burner off with appliance controls.
- Turn off power to the appliance.
- Seal the appliance flue damper test opening.
- Verify all components and wires are in place and burner is ready for operation.
- Restore power to the appliance.

Train the user

- Train the user to operate the burner and appliance under normal conditions.
- Explain procedure to shut down burner/appliance when required.
- Review the back cover of this manual (and the appliance manual) with the user.
- Verify the user is aware of all procedures specified in the manuals.
- Verify user will not store or use combustible liquids or materials or contaminants in the vicinity of the burner/appliance.

5. Annual Start-up and Service

Annual start-up & service

WARNING

This burner must be started and serviced at least annually by a qualified service technician. Failure to properly maintain and service the burner could result in severe personal injury, death or substantial property damage.

- Discuss burner/appliance operation with user to determine any problems that may have occurred during the previous season and to verify user is aware of proper operation and care of the burner/appliance.
 - Review proper operation of the appliance/burner unit with the user.
 - Turn off power to appliance.
 - Remove combustion head assembly to clean and adjust if necessary. (See procedure on page 9.)
 - If the inside surface of the air tube and/or retention ring need to be cleaned, clean them with a vacuum cleaner with brush attachment while the combustion head assembly is out of the burner.
 - Replace the oil nozzle with the correct size specified in Table 1, page 3.
 - Inspect and adjust the ignition electrodes and insulators per instructions on page 9 of this manual. Replace if proper spacing cannot be achieved or if components are damaged.
 - Close the housing cover plate and secure in place.
 - Inspect the fuel line oil filter. Replace if necessary.
- NOTICE** Oil line filters — Use a non-bypassing filter to prevent nozzle plugging caused by poor oil filtration. Non-bypassing filters prevent small foreign particles from bypassing the filter, a common problem with fiber element type filters. Another problem of some filters is the fiber from filter element tears can break away and plug the nozzle or fuel unit.
- Perform the complete checkout procedures of pages 13 to 23, including system inspection and checks.
 - Inform the user of any problems found.

6. Repair Parts For parts not shown or listed, contact factory and/or check separate documentation supplied with appliance/burner unit.

ITEM	PART NO.	DESCRIPTION	99FRD	100CRD	102CRD
1	98022S	1/6HP PSC Motor, 48 M Frame		•	•
2	82768S	Electrode set (2), – 5"	•	•	•
	82776S	Electrode set (2), – 7"	•	•	•
	82784S	Electrode set (2), – 9"	•	•	•
	82792S	Electrode set (2), – 11"	•	•	•
3	20180S	99FRD/100CRD 5" Air Tube/Combustion Head Assy	•	•	
	20230S	99FRD/100CRD 7" Air Tube/Combustion Head Assy	•	•	
	20313S	99FRD/100CRD 9" Air Tube/Combustion Head Assy	•	•	
	19919S	99FRD/100CRD 11" Air Tube/Combustion Head Assy	•	•	
	21790S	102CRD 5" B Air Tube/Combustion Head Assy			•
	21857S	102CRD 7" B Air Tube/Combustion Head Assy			•
	21881S	102CRD 9" B Air Tube/Combustion Head Assy			•
	21691S	102CRD 11" B Air Tube/Combustion Head Assy			•
	21980S	102CRD 5" C Air Tube/Combustion Head Assy			•
	21998S	102CRD 7" C Air Tube/Combustion Head Assy			•
	22004S	102CRD 9" C Air Tube/Combustion Head Assy			•
21915S	102CRD 11" C Air Tube/Combustion Head Assy			•	
4	41000S	110V Ignitor	•	•	•
	41000SOCAS	110V Ignitor on Baseplate	•	•	•
5	SVC10FFS	Oil Valve	•	•	•
	98289S	Oil Valve Kit with fittings	•	•	•
6	22996S	Fuel Unit A2VA-7116	•	•	
	98750S	Fuel Unit A2VA-3006	•	•	
	23234S	Fuel Unit A2YA-7916			•
7	34397S	Oil line kit (incl. all oil lines)	•	•	•
8	75564S	Fuel Unit Coupling	•	•	•
9	98100S	99FRD/100CRD/102CRD Air Band Shutter Single Kit	•	•	
	98101S	99FRD/100CRD/102CRD Air Band Shutter Dual Kit	•	•	•
10	5489001S	Nozzle Line adjusting slide	•		
11	51805S	Combustion Head Assy 5"	•	•	
	51854S	Combustion Head Assy 7"	•	•	
	51896S	Combustion Head Assy 9"	•	•	
	51599S	Combustion Head Assy 11"	•	•	
	52316S	Combustion Head Assy 5"			•
	52373S	Combustion Head Assy 7"			•
	52472S	Combustion Head Assy 9"			•
52183S	Combustion Head Assy 11"			•	
12	50624S	C-Ring & Thumb nut kit	•	•	•
13	50821S	Gasket kit (10 gaskets)	•	•	•
14	14407SES	Cad Cell Kit	•	•	•
15	41DTK01S	Universal Ignitor Terminal Kit (not shown)	•	•	•
16	28605S	Blower wheel / fan 99FRD	•		
	28530S	Blower wheel / fan 100CRD		•	
	28506S	Blower wheel / fan 102CRD			•

6. Repair Parts *(continued)*

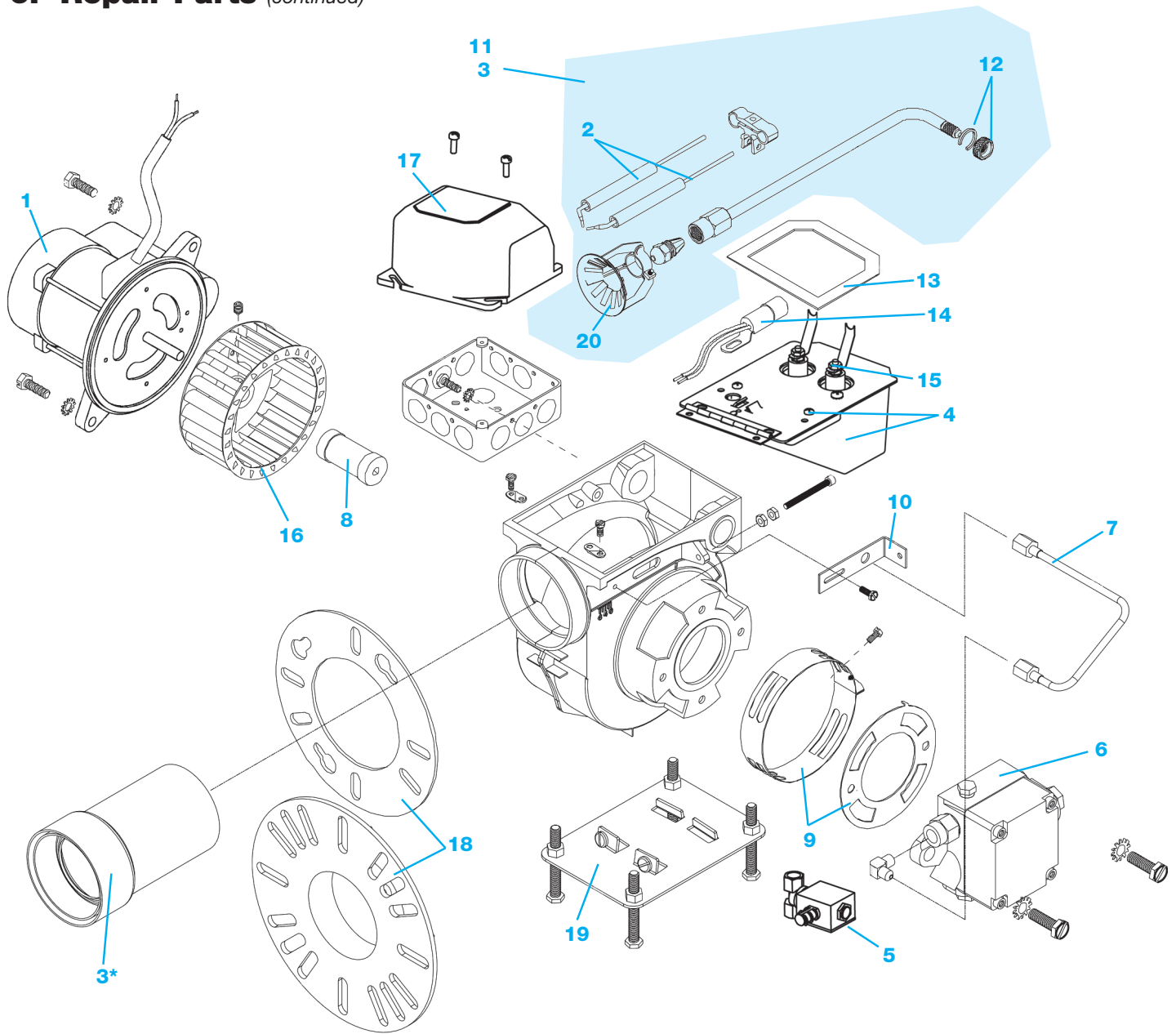

*3 includes selected air tube and combustion head assembly

ITEM	PART NO.	DESCRIPTION	99FRD	100CRD	102CRD
17	70200S	Universal Primary w/ Display 70200	•	•	•
	48245S	Model 48245 Primary w/ Smart Ignition	•	•	•
	4020002S	Model 40200 Primary 30/15/30	•	•	•
	5020002S	Model 50200 Primary 30/15/30	•	•	•
	6020002S	Model 60200 Primary 15/15/15	•	•	•
18	23150S	Mounting Flange & Gasket	•	•	•
19	23317S	Pedestal W/Hardware	•	•	•
20	54981S	Retention Ring Assy 99/100	•	•	
	55061S	Retention Ring Assy 102CRD			•

7. Maintenance Procedures

Maintenance/service procedures

WARNING Turn off power to appliance when servicing burner. Failure to comply could result in severe personal injury, death or substantial property damage.

Cleaning blower wheel

- The blower wheel accumulates dust and debris from normal operation. You will need to clean the wheel blades periodically to prevent reduction in airflow.
 - Inspect the blower wheel by removing the blower wheel access cover. See Figure 17.
 - To remove the cover, open the ignitor plate and loosen the blower wheel access cover screw about three turns.
 - Inspect the blower wheel to see if it needs to be cleaned. Dirt and lint on the wheel reduce air flow, and must be removed if the burner is to operate correctly.
- To clean blades, remove the two bolts securing the motor to blower housing.
 - Slide the motor out and rotate to remove and access blower wheel.
 - Use a brush and vacuum to clean each blade and the blower housing interior.
 - Replace motor/wheel in blower housing and secure with the two bolts.
 - Push wire slack back into junction box.

Figure 17 Remove blower access cover to inspect blower wheel

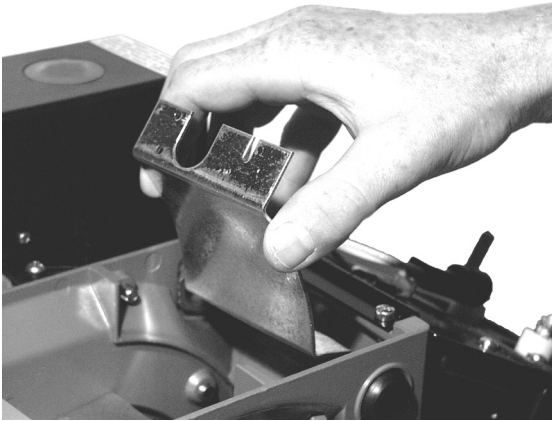

Replacing blower motor or wheel

- If either the blower wheel or motor must be replaced, remove the two bolts securing the motor to housing.
- Disconnect the motor wires in the burner junction box.
- Loosen the Allen screw securing the blower to the motor shaft and remove the wheel.
- When assembling the replacement assembly, slide the wheel onto the motor shaft and use feeler gauges to set space between the blower wheel and the motor face. This space must be:
99FRD/EZ-66 – 3/64" 102CRD – 7/16"
- Replace the motor/wheel assembly in the housing, wire the motor leads and secure the motor with the two bolts.

Motor maintenance

- The Carlin PSC motor is constructed with permanently-lubricated bearings, and requires no oiling. Should you replace the original motor with another type of motor, occasional oiling may be required, depending on motor design and manufacturer's recommendations.
- Any time you replace a component or disassemble any part of the burner for service/maintenance, perform a complete operational test after reassembly to verify the burner operates correctly. Failure to verify operation could result in severe personal injury, death or substantial property damage.

Checking ignitor

WARNING Never test an ignitor by placing a screwdriver (or other metallic object) across the high voltage clips. Check 40700 & 40900 ignitors only by observing spark at appliance ignition electrodes, with fuel supply OFF. Using any other method could cause ignitor damage and severe personal injury.

- Checking 41000 ignitors only:
 - Disconnect electrical power to burner.
 - Remove hold down clips or screws. Lift ignitor mounting plate to the full-open position. Set high voltage clips to a 1/2" to 3/4" gap.
 - Carefully energize ignitor and check for spark arcing at the high voltage terminals. If spark jumps the gap, ignitor is good.

Ceramic fiber materials

WARNING The appliance may contain ceramic fiber and/or fiberglass materials. Ceramic fiber materials, such as chamber liners, may contain carcinogenic particles (chrysothalites) after exposure to heat. Airborne particles from fiberglass or ceramic fiber components have been listed as potentially carcinogenic by the State of California. Take the following precautions when removing, replacing and handling these items.

Avoid breathing dust and avoid contact with skin or eyes. Wear long-sleeved, loose-fitting clothing, gloves and eye protection. Use a NIOSH N95 certified respirator. This respirator meets requirements for protection from chrysothalites. Actual job requirements or NIOSH regulations may require other or additional protection. For information, refer to the NIOSH website, <http://www.cdc.gov/niosh/homepage.html>.

Ceramic fiber removal: To prevent airborne dust, thoroughly wet ceramic fiber with water before handling. Place ceramic fiber materials in a plastic bag and seal to dispose.

Avoid blowing, tearing, sawing or spraying fiberglass or ceramic fiber materials. If such operations are necessary, wear extra protection to prevent breathing dust.

Wash work clothes separately from other laundry. Rinse clothes washer thoroughly afterwards to prevent contamination of other clothing.

NIOSH First aid procedures:

Eye exposure — irrigate immediately

Breathing — fresh air.

Carlin®

Combustion Technology, Inc.



WARNING The burner must be cleaned, tested and adjusted annually by a qualified oil burner service technician.

WARNING **Should overheating occur:**

- (1) shut off the oil supply to the burner.
- (2) **DO NOT** shut off the control switch to the circulator or blower.
- (3) contact your oil dealer or service technician and the fire department (if needed).

99FRD, EZ-66 and 102CRD Oil Burner

User care and maintenance

WARNING Refer only to the information on this page, intended for your use. The remainder of this manual is intended only for your service technician. Failure to comply could result in severe personal injury, death or substantial property damage.

For other than routine maintenance, contact a qualified service company. Perform the following as needed.

- Keep the area around the burner clear and free from combustible vapors and liquids.
- Do not obstruct the flow of combustion and ventilating air.
- Most motors currently used on residential type burners use permanently-lubricated bearings, and do not require field lubrication. Read the label on the motor to determine oiling needs, if any. Do not over-lubricate. This can cause as much trouble as not lubricating at all.

WARNING Never attempt to use gasoline as a fuel for this burner, as it is more combustible and could result in a serious explosion. Never attempt to burn refuse or use any fuel other than # 1 or # 2 heating oil (ASTM D396).