



# PHANTOM Series

High Efficiency Gas-Fired Hot Water  
Direct Vent Condensing Boilers

## INSTALLATION AND OPERATING INSTRUCTIONS

These instructions must be affixed on or adjacent to the boiler and retained for future reference.

### Models:

- PHNTM080
- PHNTM100
- PHNTM120
- PHNTM150
- PHNTM180



**WARNING:** Improper installation, adjustment, alteration, service or maintenance can cause property damage, injury, or loss of life. For assistance or additional information, consult a qualified installer, service agency or the gas supplier. This boiler requires a special venting system. Read these instructions carefully before installing.



Manufacturer of Hydronic Heating Products  
P.O. Box 14818 3633 I. Street  
Philadelphia, PA 19134  
[www.crownboiler.com](http://www.crownboiler.com)



---

## IMPORTANT INFORMATION - READ CAREFULLY

---

The following terms are used throughout this manual to bring attention to the presence of hazards of various risk levels, or to important information concerning product life.



### DANGER

Indicates an imminently hazardous situation which, if not avoided, will result in death, serious injury or substantial property damage.



### CAUTION

Indicates a potentially hazardous situation which, if not avoided, may result in moderate or minor injury or property damage.



### WARNING

Indicates a potentially hazardous situation which, if not avoided, could result in death, serious injury or substantial property damage.

### NOTICE

Indicates special instructions on installation, operation, or maintenance which are important but not related to personal injury hazards.



## WARNINGS FOR THE HOMEOWNER

FOLLOW ALL INSTRUCTIONS and warnings printed in this manual, the owner's manual and posted on the boiler.

MAINTAIN THE BOILER. To keep your boiler safe and efficient, have a service technician maintain this boiler as specified in Part XIII of the manual.

IF YOU ARE NOT QUALIFIED to install or service boilers, do not install or service this one.

THE BOILER MAY LEAK WATER at the end of its useful life. Be sure to protect walls, carpets, and valuables from water that could leak from the boiler.

PROTECT YOUR HOME IN FREEZING WEATHER. A power outage, safety lockout, or component failure will prevent your boiler from lighting. In winter, your pipes may freeze and cause extensive property damage. Do not leave the heating system unattended during cold weather unless alarms or other safeguards are in place to prevent such damage

DO NOT BLOCK AIR FLOW into or around the boiler. Insufficient air may cause the boiler to produce carbon monoxide or start a fire.

KEEP FLAMMABLE LIQUIDS AWAY from the boiler, including paint, solvents, and gasoline. The boiler may ignite the vapors from the liquids causing explosion or fire.

KEEP CHILDREN AND PETS away from hot surfaces of the boiler, boiler piping, vent piping and vent terminals.

CARBON MONOXIDE (CO) is an odorless, deadly gas that may be introduced into your home by any malfunctioning fuel-burning product or vent system failure. Consider installing CO alarms near bedrooms in all levels of the building to warn you and your family of potential CO exposure.



## **DANGER**

**Explosion Hazard. DO NOT store or use gasoline or other flammable vapors or liquids in the vicinity of this or any other appliance.**

**If you smell gas vapors, DO NOT try to operate any appliance - DO NOT touch any electrical switch or use any phone in the building. Immediately, call the gas supplier from a remotely located phone. Follow the gas supplier's instructions or if the supplier is unavailable, contact the fire department.**



## **WARNING**

- **Asphyxiation Hazard. This boiler requires regular maintenance and service to operate safely. Follow the instructions contained in this manual.**
- **Improper installation, adjustment, alteration, service or maintenance can cause property damage, personal injury or loss of life. Read and understand the entire manual before attempting installation, start-up operation, or service. Installation and service must be performed only by an experienced, skilled, and knowledgeable installer or service agency.**
- **This boiler must be properly vented.**
- **This boiler needs fresh air for safe operation and must be installed so there are provisions for adequate combustion and ventilation air.**
- **Asphyxiation Hazard. The interior of the venting system must be inspected and cleaned before the start of the heating season and should be inspected periodically throughout the heating season for any obstructions. A clean and unobstructed venting system is necessary to allow noxious fumes that could cause injury or loss of life to vent safely and will contribute toward maintaining the boiler's efficiency.**
- **Installation is not complete unless a safety relief valve is installed into the tapping located on left side of appliance or the supply piping. - See the Water Piping and Trim Section of this manual for details.**
- **This boiler is supplied with safety devices which may cause the boiler to shut down and not re-start without service. If damage due to frozen pipes is a possibility, the heating system should not be left unattended in cold weather; or appropriate safeguards and alarms should be installed on the heating system to prevent damage if the boiler is inoperative.**
- **Burn Hazard. This boiler contains very hot water under high pressure. Do not unscrew any pipe fittings nor attempt to disconnect any components of this boiler without positively assuring the water is cool and has no pressure. Always wear protective clothing and equipment when installing, starting up or servicing this boiler to prevent scald injuries. Do not rely on the pressure and temperature gauges to determine the temperature and pressure of the boiler. This boiler contains components which become very hot when the boiler is operating. Do not touch any components unless they are cool.**
- **Respiratory Hazard. Boiler materials of construction, products of combustion and the fuel contain alumina, silica, heavy metals, carbon monoxide, nitrogen oxides, aldehydes and/or other toxic or harmful substances which can cause death or serious injury and which are known to the state of California to cause cancer, birth defects and other reproductive harm. Always use proper safety clothing, respirators and equipment when servicing or working nearby the appliance.**
- **Failure to follow all instructions in the proper order can cause personal injury or death. Read all instructions, including all those contained in component manufacturers manuals which are provided with the boiler before installing, starting up, operating, maintaining or servicing.**
- **All cover plates, enclosures and guards must be in place at all times.**



## Table of Contents

I.	Product Description	4
II.	Specifications	4
III.	Before Installing	5
IV.	Locating The Boiler	6
V.	Mounting The Boiler	8
VI.	Air For Ventilation	11
VII.	Venting	12
	A. Vent System Design	12
	B. Design Requirements Unique to Horizontal Twin Pipe Venting Systems	18
	C. Design Requirements Unique to Vertical Venting Systems	24
	D. Design Requirements Unique to Split Vent Systems	32
	E. Assembly of CPVC/PVC Vent Systems	39
	F. Assembly of DuraVent PolyPro Vent Systems	46
	G. Assembly of Selkirk Polyflue Vent Systems	51
	H. Assembly of Centrotherm InnoFlue Vent Systems	55
	I. Condensate Trap and Drain	59
	J. Removing An Existing Boiler From Common Chimney	60
VIII.	Gas Piping	62
IX.	System Piping	64
	A. General System Piping Precaution	64
	B. Near Boiler Piping Design	65
	C. Standard Piping Installation Requirements	73
	D. Piping For Special Situations	75
X.	Wiring	76
XI.	Start-up and Checkout	84
XII.	Operation	91
XIII.	Service and Maintenance	106
XIV.	Troubleshooting	113
XV.	Parts	121
	Appendix A: LP Gas Conversion Instructions	136
	Appendix B: Special Requirements For Side-Wall Vented Appliances In The Commonwealth of Massachusetts	142

## I Product Description

This boiler is a stainless steel gas fired condensing boiler designed for use in forced hot water heating systems requiring supply water temperatures of 180°F or less. It is designed for installation on a wall. This boiler may be vented vertically or horizontally with combustion air supplied from outdoors. It is not designed for use in gravity hot water systems or systems containing significant amounts of dissolved oxygen.

## II Specifications

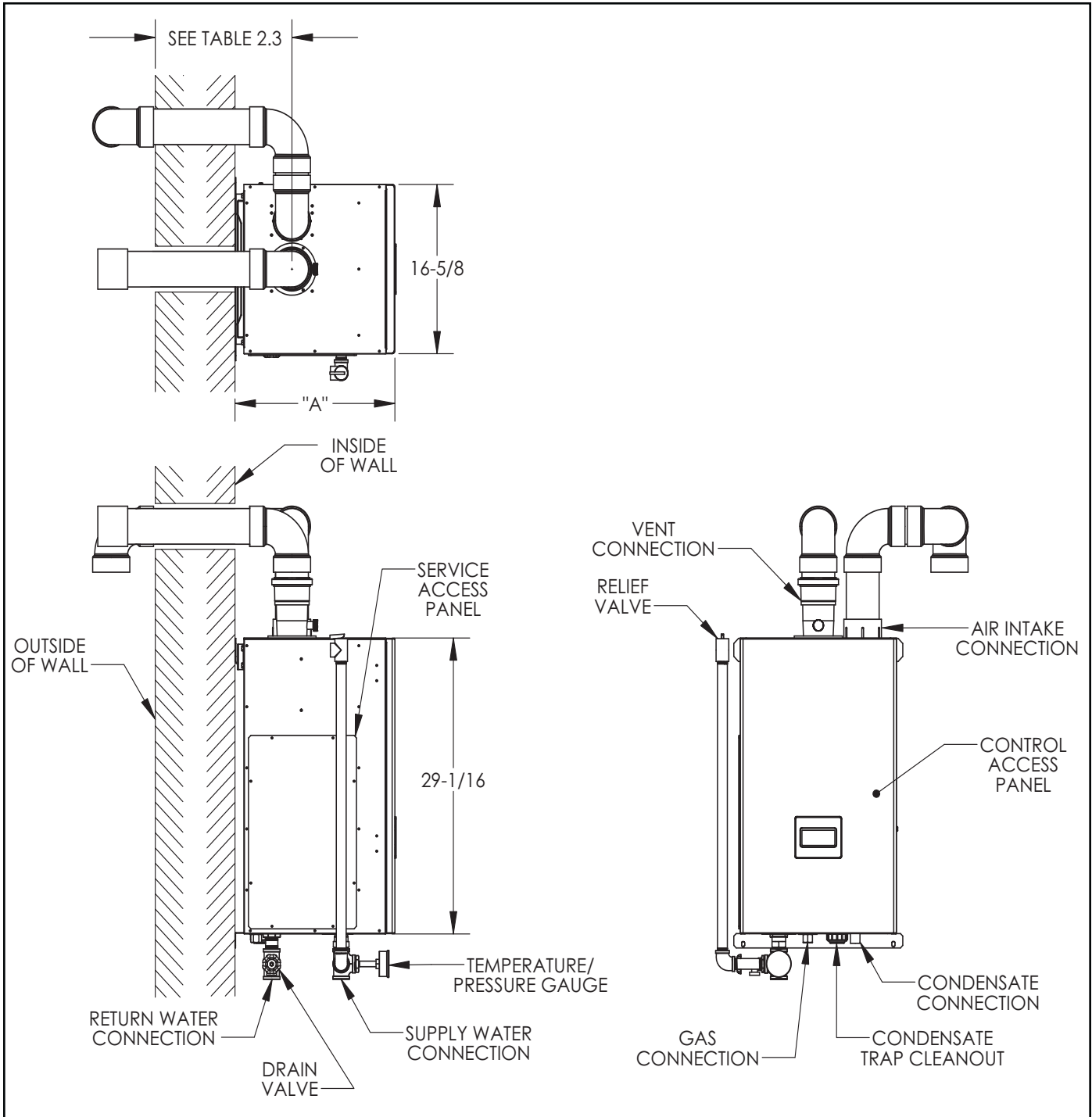

FIGURE 2.1: GENERAL CONFIGURATION

Table 2.2: Specifications

MODEL*	MAXIMUM INPUT (MBH)	MINIMUM INPUT (MBH)	D.O.E. HEATING CAPACITY (MBH)	AHRI NET RATING* (MBH)	WATER VOLUME (Gal.)	DIM "A"	SUPPLY & RETURN CONNECTION SIZE (NPT)	GAS CONNECTION SIZE (NPT)	APPROX. NET WEIGHT (lb)
PHNTM080	80	16	74	64	0.36	17"	1"	1/2"	100
PHNTM100	100	20	92	80	0.44	17"	1"	1/2"	102
PHNTM120	120	24	111	97	0.53	17"	1"	1/2"	105
PHNTM150	150	30	141	123	0.79	21"	1"	1/2"	119
PHNTM180	180	36	167	145	0.79	21"	1"	1/2"	119

\* The Net AHRI Water Ratings shown are based on a piping and pickup allowance of 1.15. The manufacturer should be consulted before selecting a boiler for installations having unusual piping and pickup requirements, such as intermittent system operation, extensive piping systems, etc.

Table 2.3: Vent Lengths

MODEL	NOMINAL VENT/INTAKE SIZE (in)	MIN VENT LENGTH (in)	MAX VENT LENGTH	APPROX. DERATE AT MAX VENT (%)
080	2	12	60ft	9
080	3	12	135ft	2
100	2	12	60ft	15
100	3	12	135ft	3
120	3	12	135ft	7
150	3	52	135ft	7
180	3	52	135ft	9

See Part VII (Venting) for additional requirements and details.

### III Before Installing

- 1) Safe, reliable operation of this boiler depends upon installation by a professional heating contractor in strict accordance with this manual and the requirements of the authority having jurisdiction.
  - In the absence of an authority having jurisdiction, installation must be in accordance with this manual and the National Fuel Gas Code, ANSI Z223.1. In Canada, installation must be in accordance with the B149.1 Installation Code.
  - Where required by the authority having jurisdiction, this installation must conform to the *Standard for Controls and Safety Devices for Automatically Fired Boilers* (ANSI/ASME CSD-1).
- 2) Read Section VII to verify that the maximum combustion air and exhaust pipe lengths will not be exceeded in the planned installation. Also verify that the vent terminal can be located in accordance with Section VII.
- 3) Make sure that the boiler is correctly sized:
  - For heating systems employing convection radiation (baseboard or radiators), use an industry accepted sizing method such as the *I=B=R* Guide RHH published by the Air-Conditioning, Heating and Refrigeration Institute (AHRI).
  - For new radiant heating systems, refer to the radiant tubing manufacturer's boiler sizing guidelines.
  - For systems which include an indirect water heater, make sure the boiler has the output called for by the indirect water heater manufacturer's instructions.

- 4) All boilers are shipped from the factory configured for use with natural gas. They may be converted for use with LP gas (“propane”) using a combustion analyzer in accordance with the instructions in Appendix A.



## **DANGER**

- **Do not attempt to operate this boiler on LP gas without converting it in accordance with the instructions shown in Appendix A.**
- **Do not attempt to convert this boiler to LP gas without the use of a combustion analyzer.**
- **Failure to follow the conversion instructions in Appendix A will result in operation of the boiler at unsafe Carbon Monoxide (CO) levels and may result in personal injury or loss of life. Improper conversion may also result in unreliable operation, resulting in property damage.**

- 5) Not all models are suitable for installation at altitudes above 2000ft. See Appendix A for additional information.

## **NOTICE**

**This product must be installed by a licensed plumber or gas fitter when installed within the Commonwealth of Massachusetts. See Appendix B for additional important information about installing this product within the Commonwealth of Massachusetts.**

## **IV Locating the Boiler**

- 1) Observe the minimum clearances shown in Figure 4.1. These clearances apply to combustible construction as well as non-combustible walls, floors, ceilings and doors.
- 2) Note the recommended service clearances in Figure 4.1. These service clearances are recommended, but may be reduced to the combustible clearances provided:
  - a. Access to the front of the boiler is provided through a door.
  - b. Access is provided to the condensate trap located beneath the boiler.

Note that servicing the boiler will become increasingly difficult as these service clearances are reduced.

- 3) Observe the following clearances from piping to combustible construction:

Non-concentric vent (exhaust): ¼”

Air intake piping: 0”

Hot water piping: ¼”

- 4) The relief valve and gauge must be installed in the location shown in Figure 2.1 and must be in the same space as the boiler.
- 5) The boiler should be located so as to minimize the length of the vent system.
- 6) The combustion air piping must terminate where outdoor air is available for combustion and away from areas that will contaminate combustion air. Avoid areas near chemical products containing chlorine, chloride based salts, chloro/fluorocarbons, paint removers, cleaning solvents and detergents.

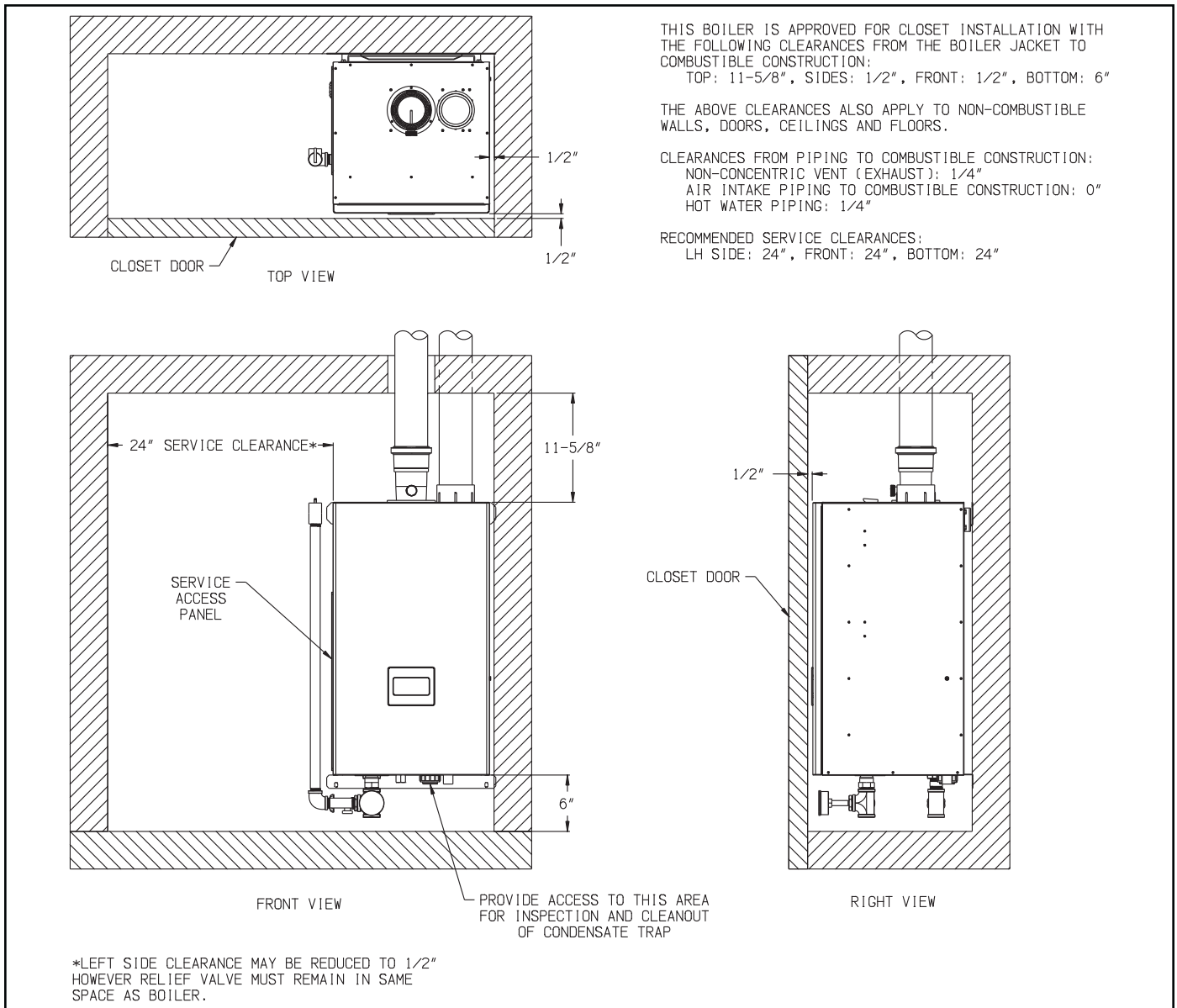

Figure 4.1: Minimum Clearances To Combustible Construction

## V Mounting The Boiler

### A. Wall Mounting



#### CAUTION

**This boiler weighs as much as 119 pounds:**

- **Two people are required to safely lift this boiler onto the wall mounting hook.**
- **Make sure that wall mounting hook is anchored to a structure capable of supporting the weight of the boiler and attached piping when filled with water. Jurisdictions in areas subject to earthquakes may have special requirements for supporting this boiler. These local requirements take precedence over the requirements shown below.**

- 1) If the boiler is installed on a framed wall, minimum acceptable framing is 2 x 4 studs on 16" centers. The boiler mounting holes are on 16" centers for installation between two studs at the standard spacing. In cases where the boiler cannot be centered between the studs, or where the studs are spaced closer than 16" apart, the boiler may be anchored to 3/4" plywood or horizontal 2 x 4s anchored to the studs.
- 2) 5/16" x 2" lag screws and washers are provided for mounting this boiler. These lag screws are intended for mounting the boiler directly onto studs covered with 1/2" sheathing. When the boiler is attached to other types of construction, such as masonry, use fasteners capable of supporting the weight of the boiler and attached piping in accordance with good construction practice and applicable local codes.
- 3) Make sure that the surface to which the boiler is mounted is plumb.
- 4) Before mounting the boiler, make sure that wall selected does not have any framing or other construction that will interfere with the vent pipe penetration.
- 5) Once a suitable location has been selected for the boiler, and any needed modifications have been made to the wall, use Figure 5.1 to locate holes "A" and "B". Make sure that the horizontal centerline of these holes is level. Holes "C" and "D" may also be drilled at this time or after the boiler is hung on the wall. If the 5/16" x 2" lag screws are used, drill 3/16" pilot holes.
- 6) The wall mounting hook is used to secure the boiler to the shipping pallet. Remove this hook from the pallet and secure to the wall using the 5/16" x 2" lag screws and washers, or other suitable anchors as appropriate (Figure 5.2). Make sure the hook is level.
- 7) Hang the boiler on the wall hook as shown in Figure 5.2.
- 8) If not already done in Step (5) locate and drill holes "C" and "D" using the obround slots in the bottom mounting flange. Secure the bottom flange to the wall using the 5/16" x 2" lag screws, or other fasteners as appropriate (Figure 5.2).
- 9) Verify that the front of the boiler is plumb. If it is not, install washers at holes "C" and "D" between the bottom mounting flange and the wall to adjust.

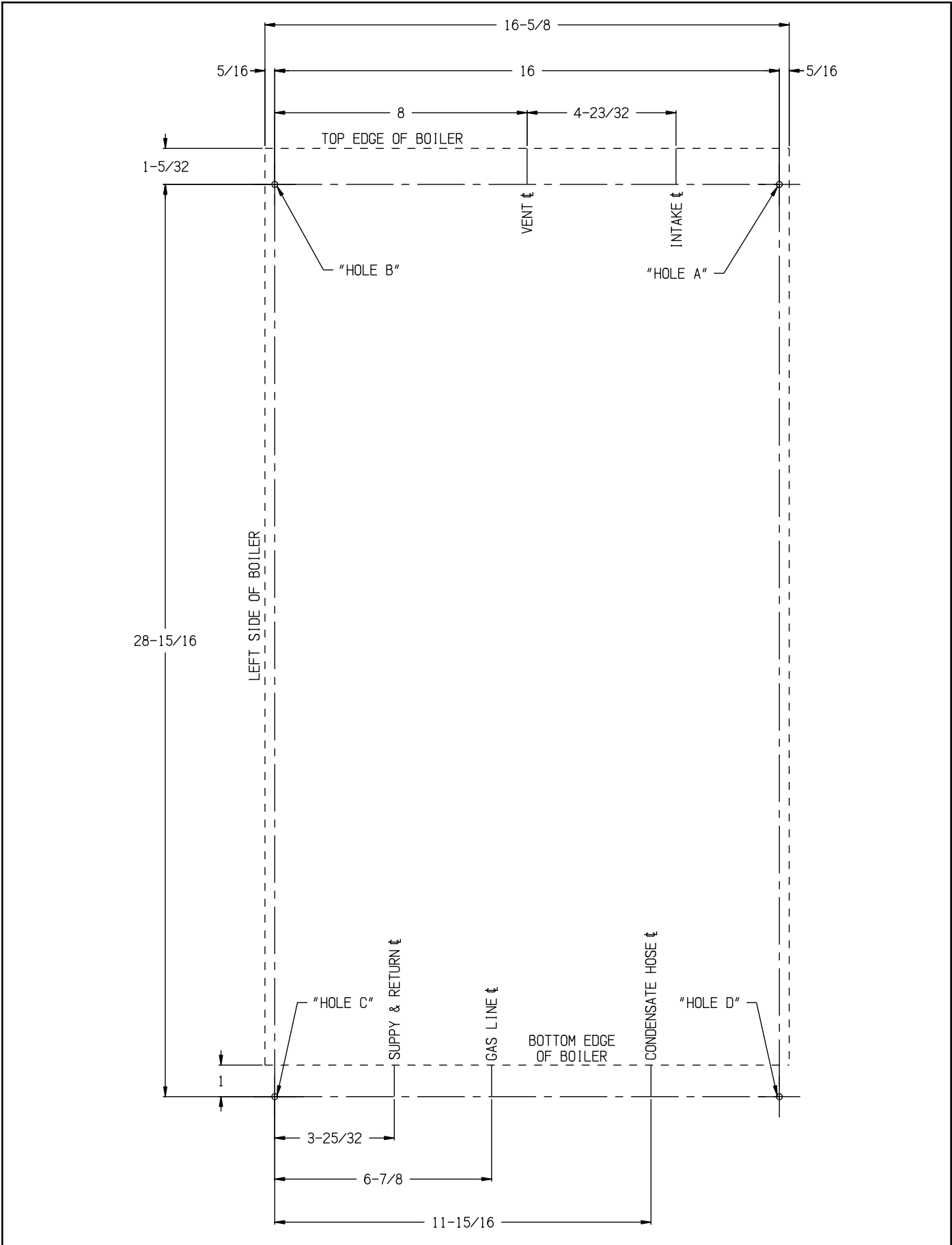

Figure 5.1 Wall Layout/Mounting Hole Location

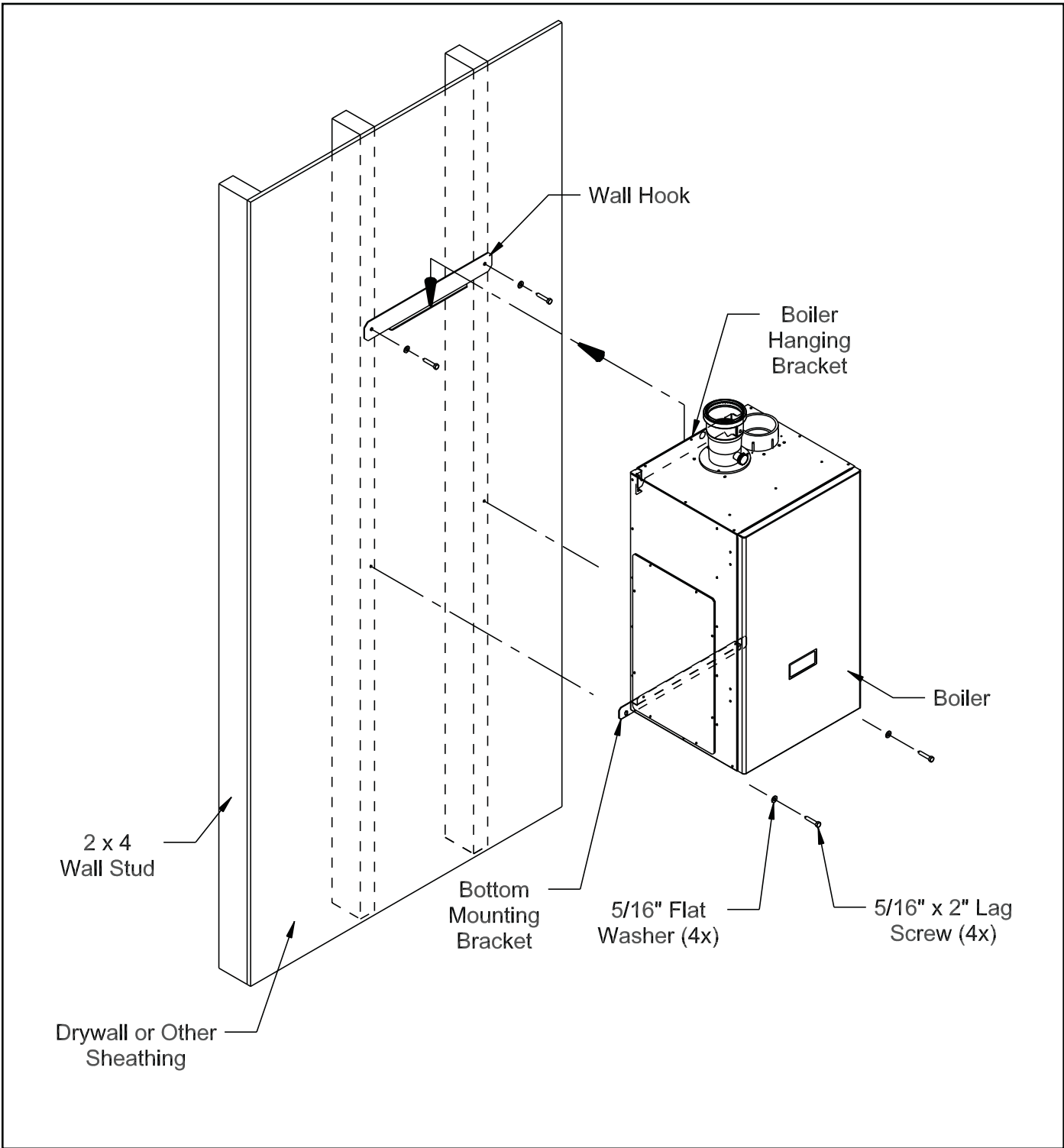

Figure 5.2 Boiler Mounting Bracket Installation / Boiler Wall Mounting



## VI Air for Ventilation



### **WARNING**

**Outdoor combustion air must be piped to the air intake. Never pipe combustion air from areas containing contaminants such as swimming pools and laundry room exhaust vents. Contaminated combustion air will damage the boiler and may cause property damage, personal injury or loss of life.**

Air for combustion must always be obtained directly from outdoors. See Section VII for intake piping. Adequate air for ventilation will be present if the clearances specified in this manual are maintained. If this boiler is installed in a room with other appliances, provide adequate air for combustion and/or ventilation air in accordance with the manufacturer's installation manual or applicable code.

## VII Venting



### WARNING

- **Asphyxiation Hazard.** Failure to vent this boiler in accordance with these instructions could cause products of combustion to enter the building resulting in severe property damage, personal injury or death.
- **Do not interchange vent systems or materials unless otherwise specified.**
- **The use of thermal insulation covering vent pipe and fittings is prohibited.**
- **Do not use a barometric damper, draft hood or vent damper with this boiler.**
- **When using the CPVC/PVC vent option, the use of CPVC is required when venting in vertical or horizontal chase ways.**
- **Any CPVC vent materials supplied with this boiler do not comply with B149.1.S1-07 and are not approved for use in Canadian jurisdictions that require vent systems be listed to ULC S636-2008. In these jurisdictions, vent this boiler using a listed ULC S636 Class IIB venting system.**
- **Do not locate vent termination where exposed to prevailing winds. Moisture and ice may form on surface around vent termination. To prevent deterioration, surface must be in good repair (sealed, painted, etc.).**
- **Do not locate air intake vent termination where chlorines, chlorofluorocarbons (CFC's), petroleum distillates, detergents, volatile vapors or other chemicals are present. Severe boiler corrosion and failure will result.**
- **The use of cellular core PVC (ASTM F891), cellular core CPVC or Radel (polyphenolsulfone) is prohibited.**
- **Do not locate vent termination under a deck.**
- **Do not reduce specified diameters of vent and combustion air piping.**
- **When installing vent pipe through chimney, as a chase, no other appliance can be vented into the chimney.**
- **Do not allow low spots in the vent where condensate may pool.**

### A. General Vent System Design

There are five basic ways to vent this boiler:

- **Horizontal (“Side Wall”) Twin Pipe Venting (Figure 7.0a)** - Vent system exits the building through an outside wall. Combustion air and flue gas are routed between the boiler and the terminal(s) using separate pipes for at least part of the way. A summary of Horizontal Twin Pipe venting options is shown in Table 7.5.
- **Vertical Twin Pipe Venting (Figure 7.0b)** - Vent system exits the building through a roof. Combustion air and flue gas are routed between the boiler and the terminal(s) using separate pipes for at least part of the way. A summary of Vertical Twin Pipe venting options is shown in Table 7.13
- **Split Venting (Figure 7.0c)** - Exhaust system exits the building through a roof, and combustion air is drawn from a terminal mounted on the side wall. A summary of split venting options is shown in Table 7.21
- **Horizontal (“Side Wall”) Concentric Venting (Figure 7.0d)** – The entire vent system is concentric from the boiler to the termination on the wall. The venting components used in this system are available through Crown distributors. Installation instructions for this system are covered in a separate vent supplement (Crown PN 980137).
- **Vertical Concentric Venting (Figure 7.0e)** – The entire vent system is concentric from the boiler to the termination on the roof. The venting components used in this system are available through Crown distributors. Installation instructions for this system are covered in a separate vent supplement (Crown PN 980137).

FIGURE 7.0 BASIC VENT OPTIONS

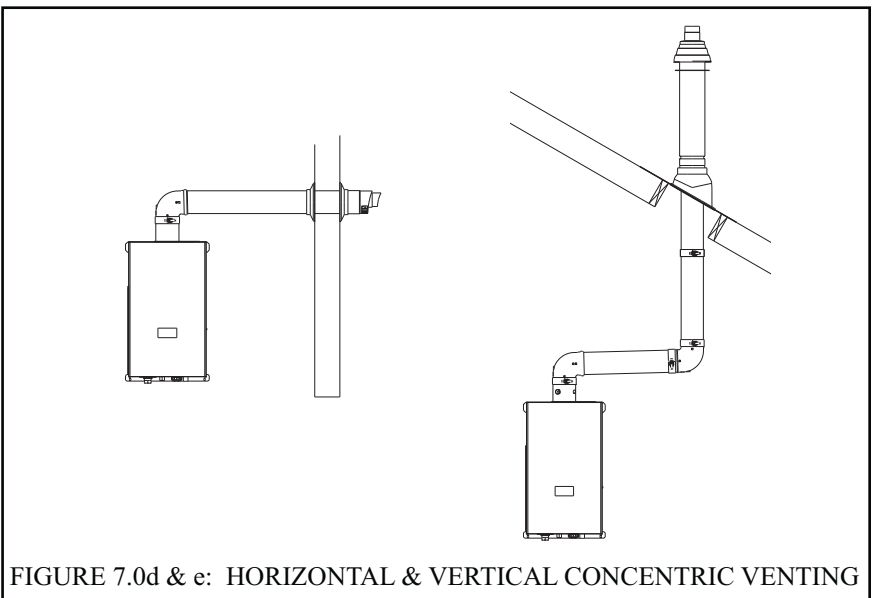
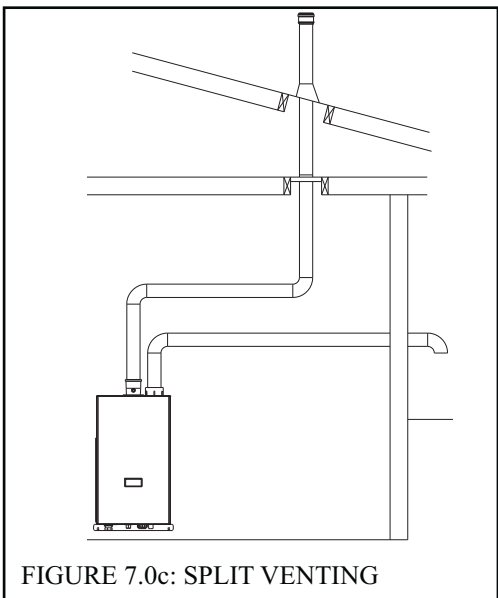
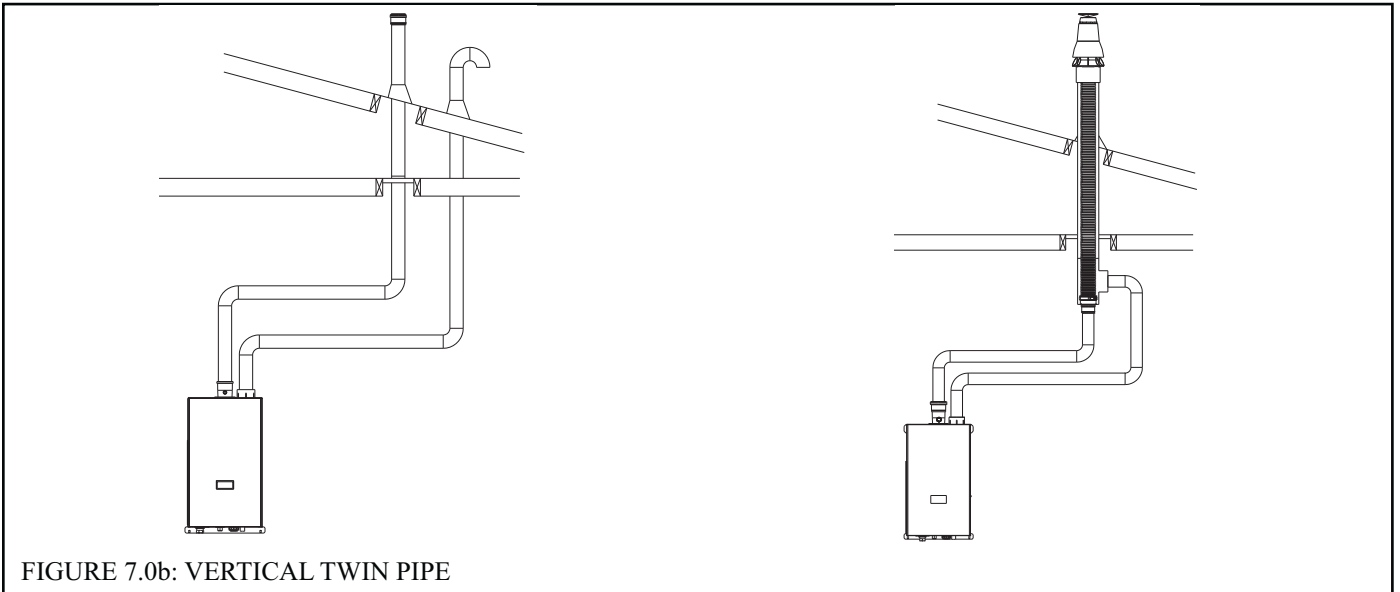
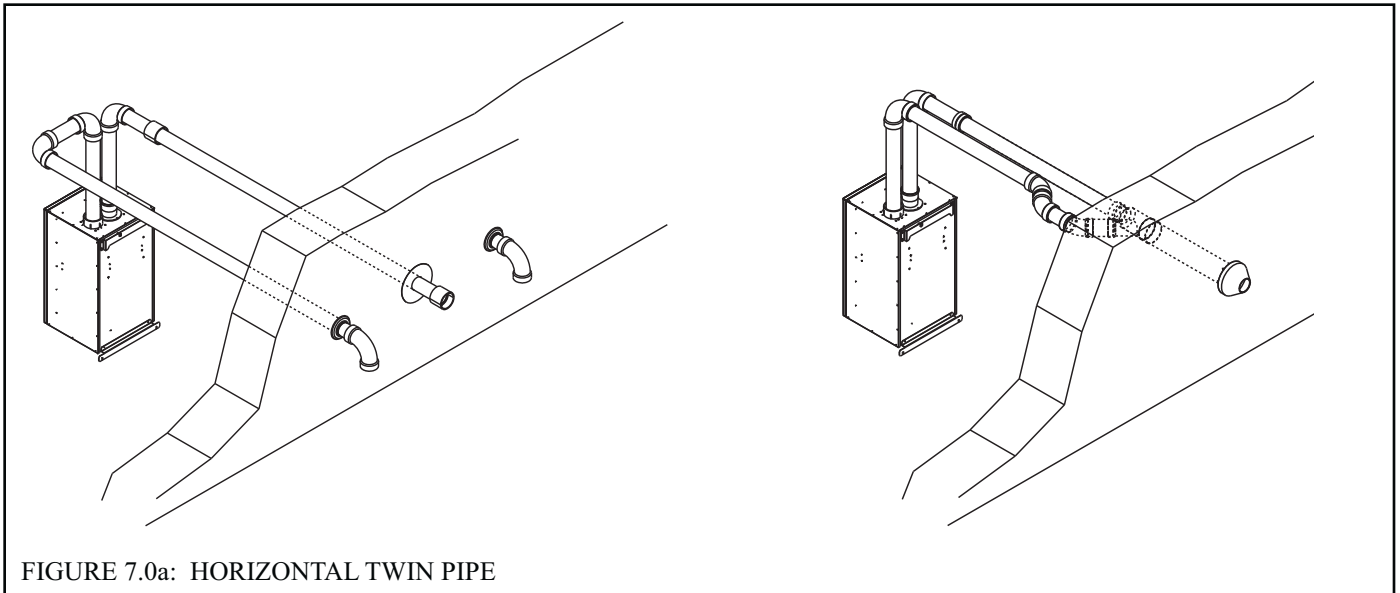

All of these systems are considered “direct vent” because the air for combustion is drawn directly from the outdoors into the boiler. One of the vent option columns in the tables referenced above must match the planned vent and air intake system exactly.

Design details applying to all vent systems are shown in this section. Observe all design requirements in this section, as well as those unique to the type of system being installed:

- B – Design Requirements Unique to Horizontal Twin Pipe Vent Systems
- C - Design Requirements Unique to Vertical Twin Pipe Vent systems
- D- Design Requirements Unique to Split Vent Systems

1. Approved Vent Systems and Materials – The following materials and vent systems may be used to vent this boiler:

- CPVC – Use only CPVC listed to ASTM F441. In Canada, this pipe must also be listed to ULC S636.
- PVC – PVC may be used only as permitted in this manual. All PVC must be listed to ASTM D2665. At least 30” of CPVC pipe, and at least one CPVC elbow, must be installed between the boiler’s vent connection and the PVC pipe. Use of foam core PVC is not permitted for venting. PVC vent pipe may not be used to vent this boiler in Canada.
- DuraVent PolyPro - ULC S636 listed polypropylene special gas vent system.
- Selkirk Polyflue - ULC S636 listed polypropylene special gas vent system.
- Centrotherm InnoFlue SW - ULC S636 listed polypropylene special gas vent system.

Use PVC and/or CPVC for the air intake system. PVC may be used for all air intake piping between the intake terminal and the boiler.

When CPVC and/or PVC pipe is used, it must be joined using primer and cement that is listed for use with the pipe material being joined (PVC, CPVC, or CPVC to PVC).

2. Vent Components Supplied with this Boiler – This boiler is supplied with some of the components needed for 3” CPVC/PVC venting (Vent Option 2). A list of these components is supplied in Table 7.26. Components not supplied may be procured locally. The CPVC Pipe and elbow supplied with this boiler are not listed to ULC S636 and may not be used in Canada.

3. Maximum Vent and Air Intake Lengths - The maximum length of the vent air intake piping depends upon the vent option selected and the boiler size. See Tables 7.5, 7.13 or 7.21 for the maximum vent lengths. These maximum lengths apply to both the vent and intake piping (e.g. Option 1 may have up to 60ft of intake and 60ft of vent piping). For all vent systems, the lengths shown in Tables 7.5, 7.13 and 7.21 are in addition to the first 90° elbow. If more elbows are desired, the maximum allowable vent length must be reduced by the amount shown in Table 7.1 for each additional elbow used. Termination fittings are never counted.

The elbows supplied with the boiler are “standard radius” elbows. It is recommended that all field supplied PVC or CPVC elbows be “1/4 Bend” (Sanitary 90° El) or “Long Sweep 1/4 Bend” type elbows (Figure 7.2). In this manual “sanitary” and “long sweep” elbows are treated as having the same equivalent length.

*Example:*

*A 3” twin pipe horizontal CPVC/PVC vent system is planned for a horizontally vented 120MBH model which has the following components in the vent system:*

- 1 ft CPVC Straight Pipe
- 90 CPVC Elbow (short bend)
- 1-1/2 ft CPVC Straight Pipe
- Coupling
- 10 ft PVC Straight Pipe
- 90 PVC Elbow (Sanitary Elbow Design)
- 15 ft PVC Straight Pipe
- PVC Coupling Terminal

*The Vent Option #2 column in Table 7.5 describes a horizontal direct vent system using 3” CPVC and PVC pipe. From this column, we see that the boiler may have a vent length of up to 135ft. The first CPVC 90 degree elbow is not considered. From Table 7.1, we see that the equivalent length of the 90 PVC elbow is 4ft and that the equivalent length of the coupling is 0ft. The total equivalent length of the planned venting system is therefore:*

*1ft (Straight CPVC) + 0ft (first short bend CPVC 90 Elbow) + 1.5ft (Straight CPVC) + 0ft (Coupling) + 10ft (Straight PVC) + 4ft (PVC 90 Sanitary Elbow) + 15ft (Straight PVC) + 0ft (Coupling Terminal) = 31.5ft.*

*Since Table 7.5 shows a maximum allowable vent length of 135ft, the planned vent system length is acceptable*

The flex venting used on some of the Vertical Twin Pipe and Split Vent Options also reduces the maximum allowable vent length. See Sections VII-C or VII-D for details.

## NOTICE

**Do not exceed maximum vent/combustion air system length. Refer to Tables 7.1, 7.13 and 7.21 in this section for maximum vent/combustion air system length.**

**Use only vent and combustion air terminals and terminal locations shown in Tables 7.1, 7.13 and 7.21 and related Figures.**

4. Minimum Vent and Air Intake Lengths - Observe the minimum vent lengths shown in Tables 7.1, 7.13 and 7.21.
5. Clearances to Combustibles - Maintain the following clearances from the vent system to combustible construction:
  - Vent - 1/4" (also observe clearances through both combustible and non-combustible walls - see 9 below)
  - Air Intake - 0"
  - Concentric Portion of Concentric Terminals - 0"
6. Pitch of Horizontal Vent Piping - Pitch all horizontal vent piping so that any condensate which forms in the piping will run towards the boiler.
  - Pitch CPVC/PVC vent piping 1/4" per foot.
  - Pitch polypropylene vent piping 5/8" per foot.

Les chaudières de catégories I, II et IV doivent présenter des tronçons horizontaux dont la pente montante est d'au moins 5/8 po par pied (52 mm/m) entre la chaudière et l'évent.

TABLE 7.1: VENT/ AIR INTAKE FITTING EQUIVALENT LENGTH

CPVC/PVC FITTING	EQUIVALENT LENGTH (ft)	POLYPRO, POLYFLUE OR INNOFLUE VENT FITTING	EQUIVALENT LENGTH (ft)
2" 90 ELBOW ("SANITARY BEND")	2.6	2" 90 ELBOW	4.5
3" 90 ELBOW ("SANITARY BEND")	4.0	3" 90 ELBOW	8.7
2" 90 ELBOW ("SHORT BEND")	6.0	2" 45 ELBOW	2.5
3" 90 ELBOW ("SHORT BEND")	10.0	3" 45 ELBOW	4.6
2" 45 ELBOW	1.5		
3" 45 ELBOW	2.0		
2" COUPLING	0.0		
3" COUPLING	0.0		

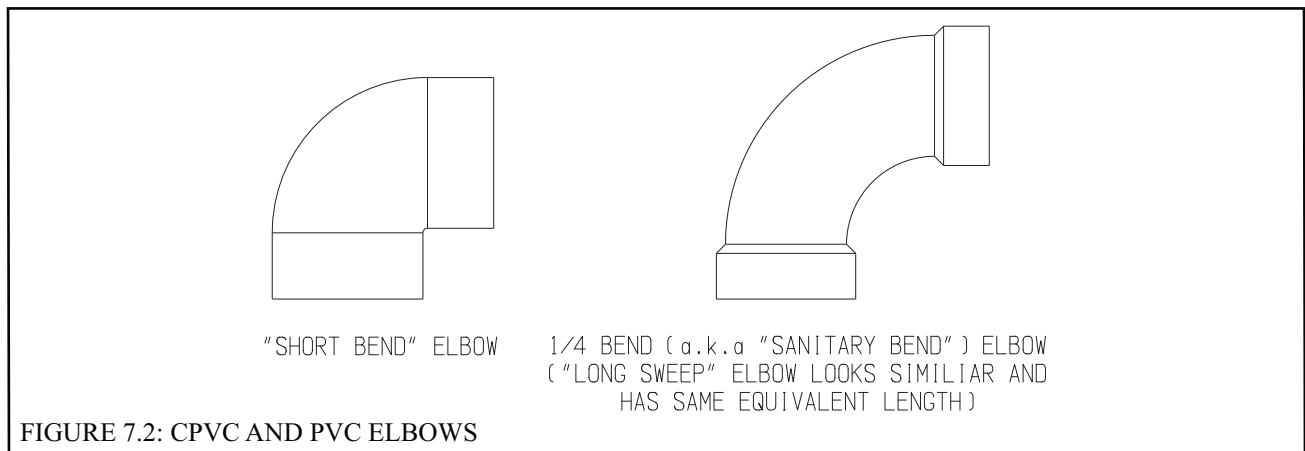

7. Supporting Pipe - Vertical and horizontal sections of pipe must be properly supported. Maximum support spacing is as follows:

- Support CPVC/PVC horizontally and vertically every 4 feet.
- Support DuraVent Polypro horizontally near the female end of each straight section of pipe and vertically every 10 feet.
- Support Centrotherm InnoFlue horizontally every 39 inches with additional supports at elbows and vertically every 78”.
- Support 2” Selkirk Polyflue horizontally every 30”. Support 3” Polyflue horizontally every 39”. Support vertical runs of both 2” and 3” Polyflue every 16 ft.

Les instructions d’installation du système d’évacuation doivent préciser que les sections horizontales doivent être supportées pour prévenir le fléchissement. Les méthodes et les intervalles de support doivent être spécifiés. Les instructions doivent aussi indiquer les renseignements suivants:

- les chaudières de catégories II et IV doivent être installées de façon à empêcher l’accumulation de condensat: et
- si nécessaire, les chaudières de catégories II et IV doivent être pourvues de dispositifs d’évacuation du condensat.

8. Allowing for Thermal Expansion -

- For CPVC/PVC pipe design the vent system to allow 3/8” of thermal expansion for every 10ft of CPVC/PVC pipe. The boiler will always act as an anchor to one end of the vent system. If at all possible, select and install hangers and wall thimbles so that the vent system can expand towards the terminal. When a straight run of pipe exceeds 20ft and must be restrained at both ends, an offset or expansion loop must be provided (Figures 7.3a, 7.3b). When a straight horizontal run of pipe exceeds 20ft and is restrained at one end with an elbow at the other, avoid putting a hanger or guide less than “Y” inches from the elbow in the adjoining straight section (Figure 7.3c). Thermal expansion fittings are not permitted.
- When properly assembled expansion of Polypro, Polyflue and InnoFlue vent systems is accommodated at the joints. See Part VII-F, G & H of this manual for details.

9. Running PVC Vent Pipe Inside Enclosures and Through Walls - PVC vent pipe must be installed in a manner that permits adequate air circulation around the outside of the pipe:

- Do not enclose PVC venting - Use CPVC in enclosed spaces, even if PVC is installed upstream.
  - PVC venting may not be used to penetrate combustible or non-combustible walls unless all of the following conditions are met:
    - a. The wall penetration is at least 66 inches from the boiler as measured along the vent.
    - b. The wall is 12” thick or less
    - c. An airspace of at least that shown in Figure 7.4 is maintained around the OD of the vent.
- If any of these conditions cannot be met, use CPVC for the wall penetration.

10. Vent Manufacturer’s Instructions – The vent system manufacturer may have additional vent system design requirements. Read and follow the vent manufacturer’s instructions in addition to those shown here. Where a conflict arises between the two sets of instructions, the more restrictive requirements shall govern.

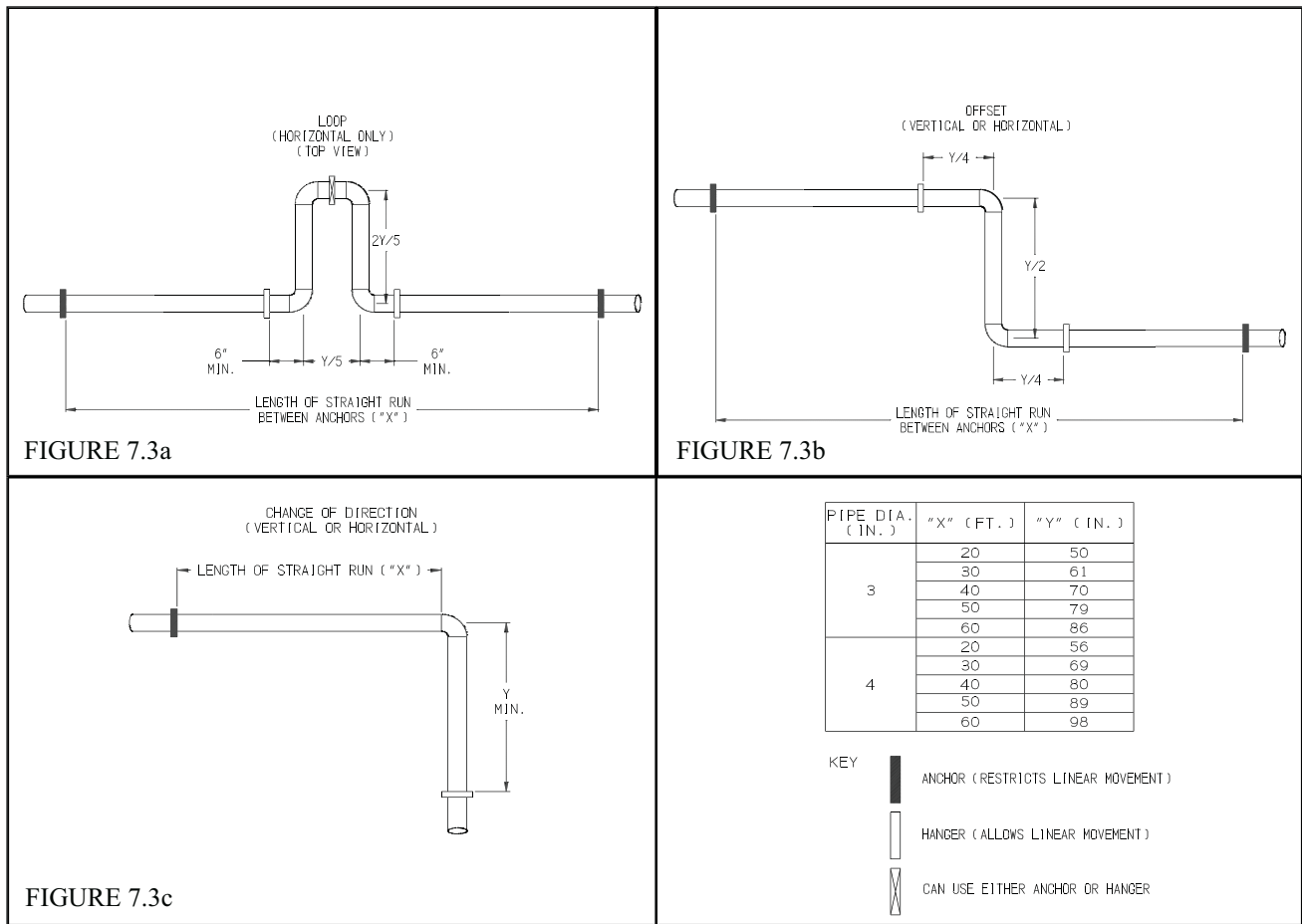

**FIGURE 7.3: EXPANSION LOOPS FOR CPVC/PVC PIPE**

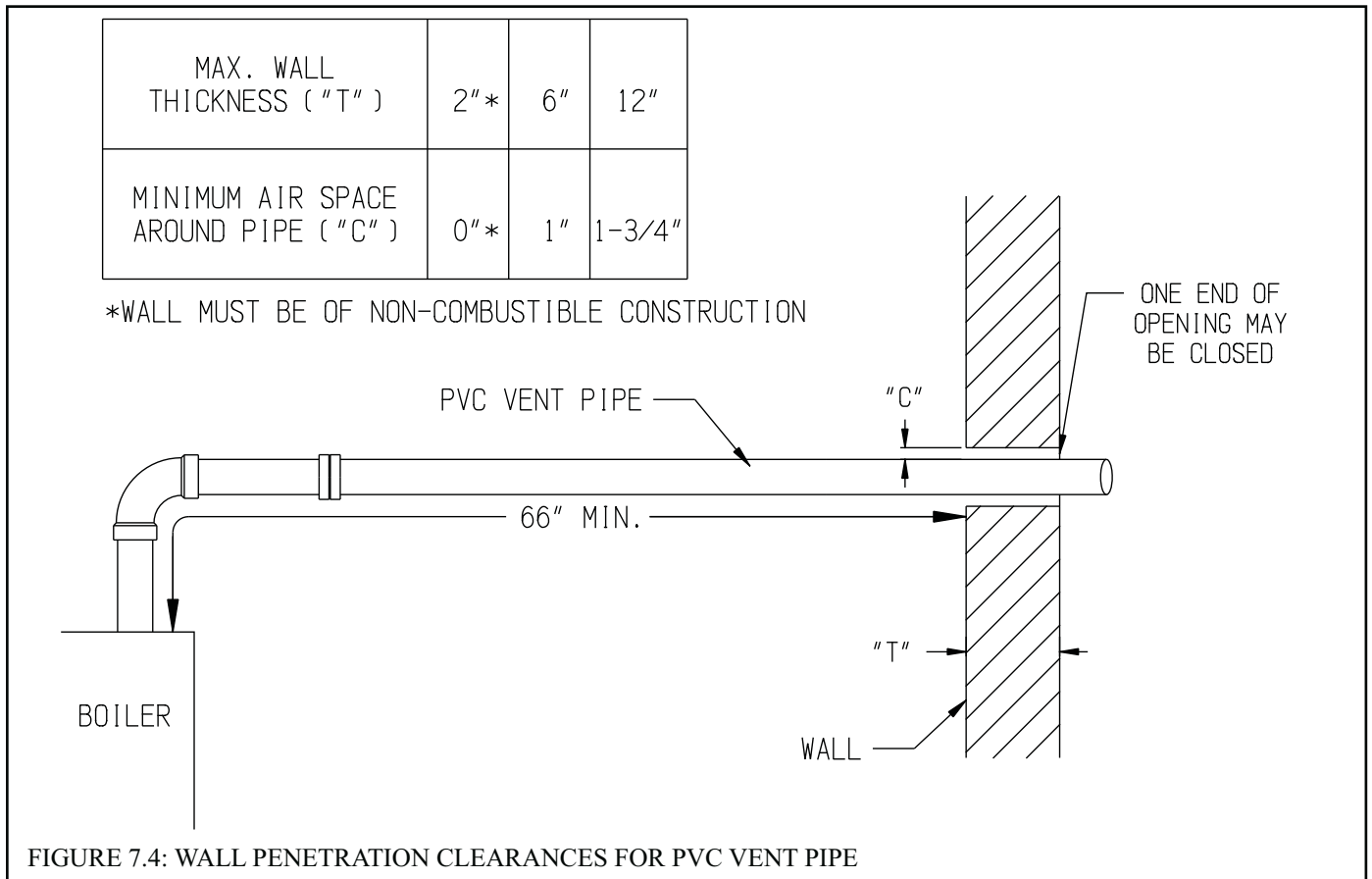

## B. Design Requirements Unique to Horizontal Twin Pipe Venting Systems

Table 7.5 summarizes all horizontal twin pipe vent options. Illustrations of horizontal twin pipe vent systems are shown in Figures 7.6 – 7.10. In addition to the requirements in Part VII-A, observe the following design requirements:

### 1. Permitted Terminals for Horizontal Venting:

**Terminal Option A: Fittings (Acceptable for Vent Options 1-8)** – Vent terminates in a plain end (coupling for PVC, bell end for Polypro, Polyflue and plain end pipe for InnoFlue). Intake terminates in a PVC 90 sweep elbow pointing down. Outer edge of both terminals must be within 10” of the wall surface (Figures 7.6, 7.9). The section of DuraVent Polypro, Centrotherm InnoFlue or Selkirk Polyflue exposed to the outdoors must be UV resistant.

Use of rodent screens is generally recommended for both terminations. Two rodent screens suitable for 3” PVC terminals are supplied with the boiler and are installed as shown in Figure 7.28. If 2” CPVC is used, these screens can be cut to fit into the smaller fittings. Rodent screens (“bird guards”) for PolyPro, InnoFlue and Polyflue are as follows:

Size/Vent System	Rodent Screen (“Bird Guard”)
2” Polypro	DuraVent # 2PPS-BG
3” Polypro	DuraVent # 3PPS-BG
2” Polyflue	Selkirk # 2PF-HVST
3” Polyflue	Selkirk # 3PV-HVST
2” InnoFlue	Centrotherm # IASPP02
3” InnoFlue	Centrotherm # IASPP03

If necessary to achieve required clearance above grade, CPVC or CPVC/PVC vent systems may be terminated using fittings on snorkels as shown in Figure 7.12. When this is done, the equivalent length of all pipe on the exterior of the building, except for the terminal fittings themselves, must be counted when calculating the equivalent length. The maximum vertical run of the snorkel is 7 feet. Brace both the vent and inlet piping if required. Polypro, InnoFlue and Polyflue may not be snorkeled.

**Terminal Option B: Ipex Low Profile Terminal (Acceptable for Vent Options 1,2)** – This terminal is shown in Figure 7.7. If the terminal is oriented vertically (alternate orientation shown in Fig 7.7) the exhaust opening must be on the top as shown. See Part VII-E of this manual and the Ipex instructions provided with the terminal, for installation details.

**Terminal Option C: Diversitech “Low Profile” Terminal (Acceptable for Vent Options 1,2)** – This terminal is shown in Figure 7.7. If the terminal is oriented vertically (alternate orientation shown in Fig 7.7) the exhaust opening must be on the top as shown. See Part VII-E of this manual and the Diversitech instructions provided with the terminal, for installation details.

**Terminal Option D: Ipex FGV Concentric Terminal (Acceptable for Vent Options 1,2)** - This terminal is shown in Figure 7.8 and may be used with CPVC/PVC vent systems. This terminal is available in various lengths and in both PVC and CPVC. Terminals acceptable for use with these vent options are as follows:

Ipex PN	FGV Concentric Terminal Description
196005	2 x 16” PVC
196105	2 x 28” PVC
196125	2 x 40” PVC
196006	3 x 20” PVC
196106	3 x 32” PVC
196116	3 x 44” PVC
197107	3 x 32” CPVC
197117	3 x 44” CPVC

See Part VII-E of this manual and the Ipex instructions provided with the terminal, for installation details.

**Terminal Option E: Diversitech Concentric Terminal (Acceptable for Vent Options 1,2)** - This terminal is shown in Figure 7.8 and may be used with CPVC/PVC vent systems. See Part VII-E of this manual and the Diversitech instructions provided with the terminal, for installation details.

**Terminal Option F: DuraVent PolyPro Concentric Terminal (Acceptable for Vent Options 3,4)** - This terminal is shown in Figure 7.10 and may be used with DuraVent 2” or 3” PolyPro vent systems. See Part VII-F of this manual and the DuraVent instructions provided with the terminal, for installation details.



Table 7.5: Summary of Horizontal Twin Pipe Venting Options

<b>Vent Option</b>		<b>1</b>	<b>2</b>	<b>3</b>	<b>4</b>	<b>5</b>	<b>6</b>	<b>7</b>	<b>8</b>
Illustrated in Figure		7.6, 7.7, 7.8	7.6, 7.7, 7.8	7.9, 7.10	7.9, 7.10	7.9	7.9	7.9	7.9
Pipe Penetration through Structure	Vent	Wall	Wall	Wall	Wall	Wall	Wall	Wall	Wall
	Intake	Wall	Wall	Wall	Wall	Wall	Wall	Wall	Wall
Material	Vent	CPVC/ PVC (Note 2)	CPVC/ PVC (Note 2)	DuraVent PolyPro (Rigid)	DuraVent PolyPro (Rigid)	Selkirk Polyflue	Selkirk Polyflue	Centro- therm InnoFlue SW	Centro- therm InnoFlue SW
	Intake	PVC	PVC	PVC	PVC	PVC	PVC	PVC	PVC
Nominal Diameter	Vent	2"	3"	2"	3"	2"	3"	2"	3"
	Intake	2"	3"	2"	3"	2"	3"	2"	3"
Min Equivalent Vent Length:									
Models	080	12"	12"	12"	12"	12"	12"	12"	12"
	100	12"	12"	12"	12"	12"	12"	12"	12"
	120	Not Permitted	12"	Not Permitted	12"	Not Permitted	12"	Not Permitted	12"
	150		52"		52"		52"		
	180		52"		52"		52"		
Max Equivalent Vent Length (Note 1):									
Models	080	60ft	135ft	60ft	135ft	60ft	135ft	60ft	135ft
	100	60ft	135ft	60ft	135ft	60ft	135ft	60ft	135ft
	120	Not Permitted	135ft	Not Permitted	135ft	Not Permitted	135ft	Not Permitted	135ft
	150		135ft		135ft		135ft		
	180		135ft		135ft		135ft		
<b>Terminal Option A</b> (Fittings)	Vent	Coupling w Screen (Note 3)	Coupling w Screen (Note 3)	2PPS-12B or 2PPS-36B w Screen	3PPS-12B or 3PPS-36B w Screen	2PF-10UV or 2PF-39UV w Screen	3PF-10UV or 3PF-39UV w Screen	ISEP02 or ISEP0239 w Screen	ISEP03 or ISEP0339 w Screen
	Intake	Elbow w Screen (Note 3)	Elbow w Screen (Note 3)	Elbow w Screen	Elbow w Screen	Elbow w Screen	Elbow w Screen	Elbow w Screen	Elbow w Screen
<b>Terminal Option B</b> (Iplex Low Profile)		Iplex # 196984	Iplex #196985	Not Permitted	Not Permitted	Not Permitted	Not Permitted	Not Permitted	Not Permitted
<b>Terminal Option C</b> (Diversitech HVENT)		HVENT-2	HVENT-3	Not Permitted	Not Permitted	Not Permitted	Not Permitted	Not Permitted	Not Permitted
<b>Terminal Option D</b> (Iplex FGV Concentric)		Iplex 196105	Iplex 196006	Not Permitted	Not Permitted	Not Permitted	Not Permitted	Not Permitted	Not Permitted
<b>Terminal Option E</b> (Diversitech CVENT)		CVENT-2	CVENT-3	Not Permitted	Not Permitted	Not Permitted	Not Permitted	Not Permitted	Not Permitted
<b>Terminal Option F</b> (DuraVent Horizontal Concentric)		Not Permitted	Not Permitted	2PPS-HK	3PPS-HK	Not Permitted	Not Permitted	Not Permitted	Not Permitted

Notes:

- 1) Max vent lengths shown also apply to the intake. For example, Vent Option #1 may have up to 60ft of vent pipe and also up to 60 ft of intake pipe.
- 2) First 30" of vent and vent Elbow connected to boiler must be CPVC. Downstream vent pipe can be PVC except as noted in text.
- 3) PVC Terminal coupling and inlet elbow may be offset on snorkels as shown in Figure 7.12.

2. Horizontal Vent and Air Intake Terminal Location - Observe the following limitations on the vent terminal location (also see Figure 7.11). When locating a concentric terminal, observe the limitations outlined below for “vent terminals”.

- Vent terminal must be at least 1 foot from any door, window, or gravity inlet into the building.
- When Terminal Option A (fittings) are used, maintain the correct clearance and orientation between the intake and exhaust terminals. The recommended horizontal spacing between inlet and exhaust terminals is 36”, however this spacing may be reduced to 12” (center-to-center) if necessary. The elevation of the exhaust terminal must be at, or above, that of the intake terminal. The 12” minimum horizontal spacing must be maintained regardless of the vertical separation between the intake and exhaust terminals. Both terminals must be located on the same wall.
- The bottom of all terminals must be at least 12” above the normal snow line. In no case should they be less than 12” above grade level.
- The bottom of the vent terminal must be at least 7 feet above a public walkway.
- Do not install the vent terminal directly over windows or doors.
- The bottom of the vent terminal must be at least 3 feet above any forced air inlet located within 10 feet.
- USA Only: A clearance of at least 4 feet horizontally must be maintained between the vent terminal and gas meters, electric meters, regulators, and relief equipment. Do not install vent terminal over this equipment. In Canada, refer to B149.1 Installation Code for clearance to meters, regulators and relief equipment.
- Do not locate the vent terminal under decks or similar structures.
- Top of terminal must be at least 60” below ventilated eaves, soffits and other overhangs. In no case may the overhang depth exceed 36”. Where permitted by the authority having jurisdiction and local experience, the terminal may be located closer to unventilated soffits. The minimum vertical separation depends upon the depth of the soffit. See Figure 7.10c for details.
- Vent terminal must be at least 6 feet from an inside corner.
- Under certain conditions, water in the flue gas may condense, and possibly freeze, on objects around the vent terminal including on the structure itself. If these objects are subject to damage by flue gas condensate, they should be moved or protected.
- Install the vent and air intake terminals on a wall away from the prevailing wind. Reliable operation of this boiler cannot be guaranteed if these terminals are subjected to winds in excess of 40 mph.
- Air intake terminal must not terminate in areas that might contain combustion air contaminants, such as near swimming pools. See WARNING on page 12.

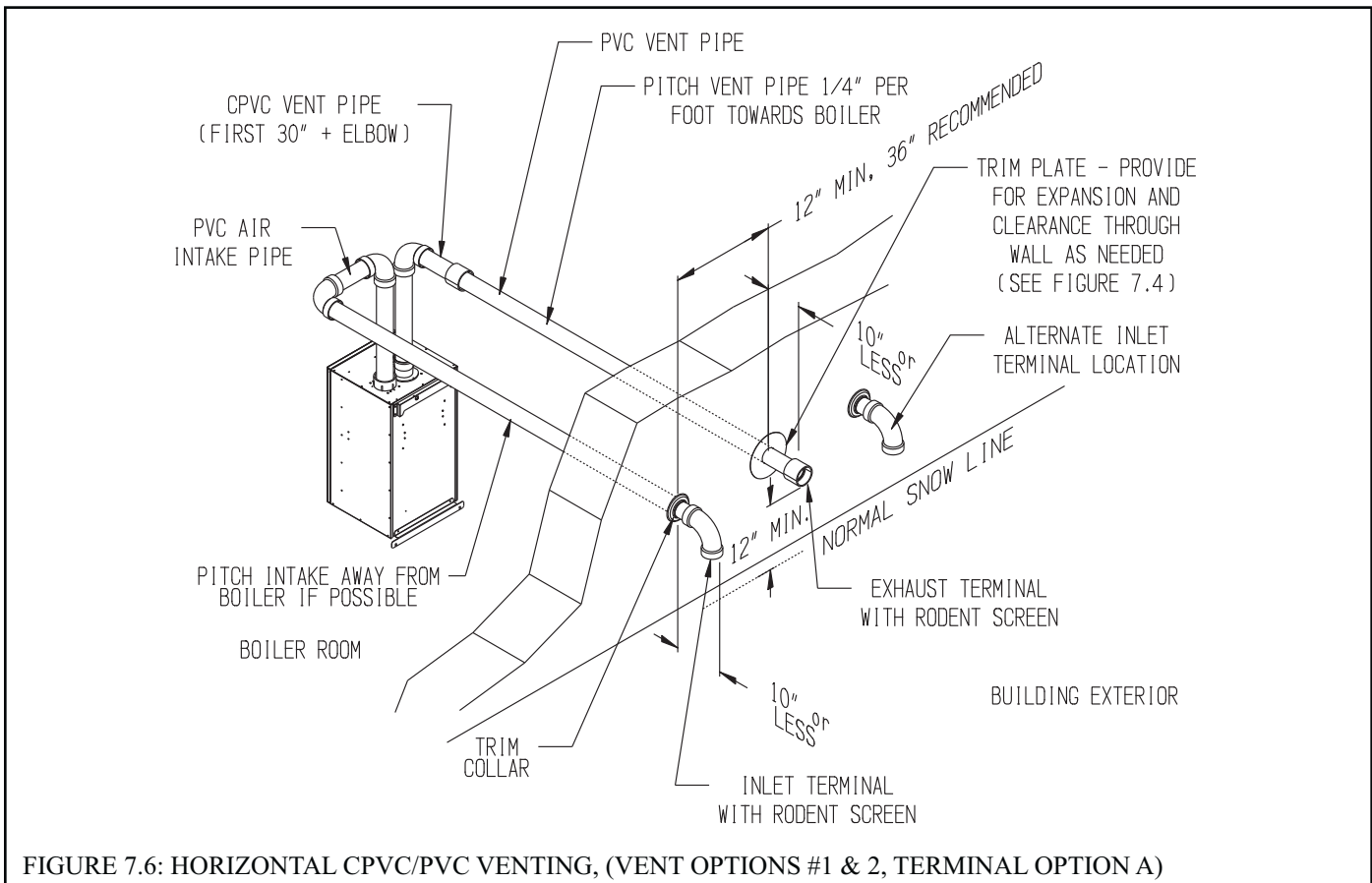

FIGURE 7.6: HORIZONTAL CPVC/PVC VENTING, (VENT OPTIONS #1 & 2, TERMINAL OPTION A)

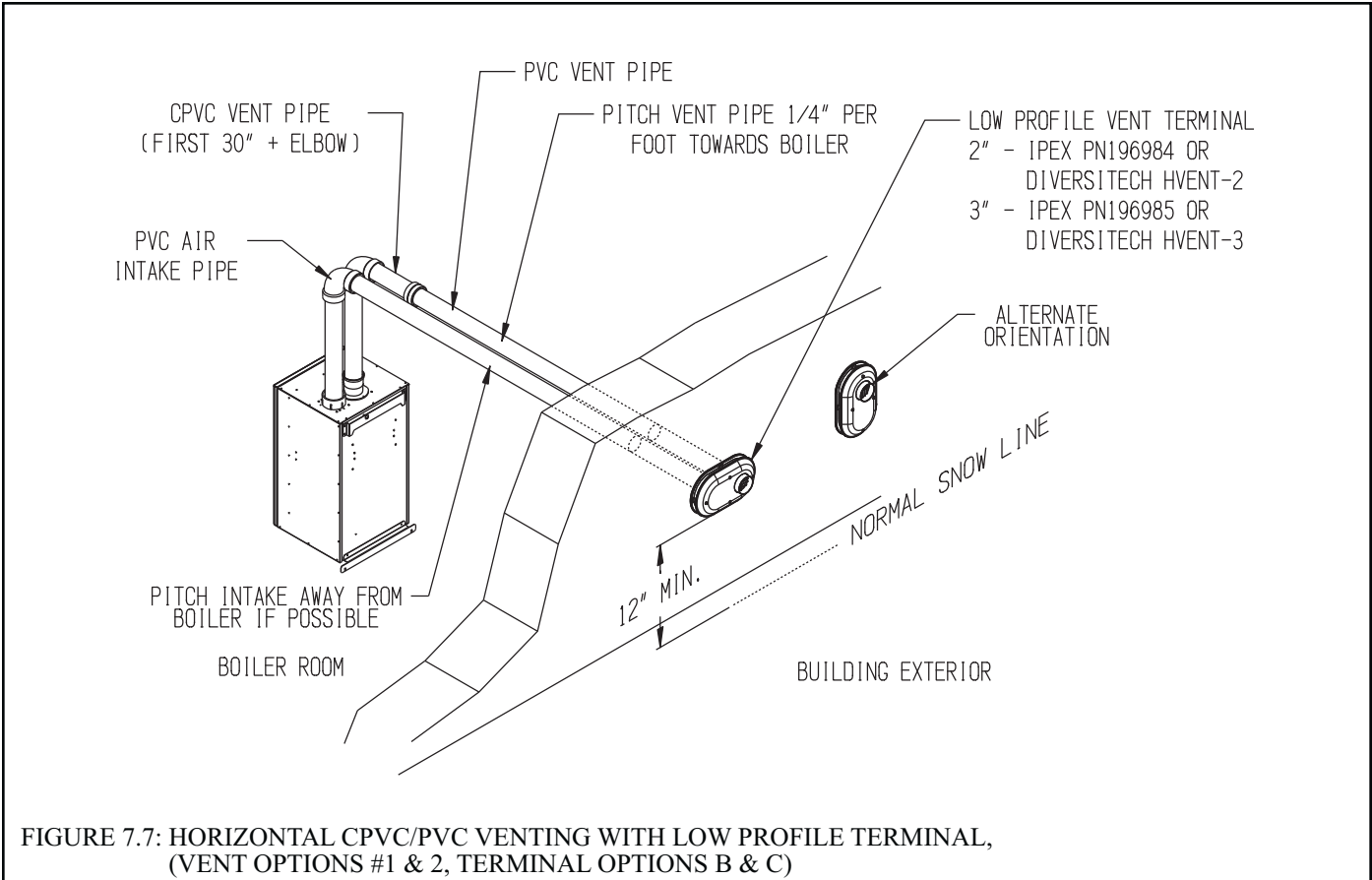

FIGURE 7.7: HORIZONTAL CPVC/PVC VENTING WITH LOW PROFILE TERMINAL, (VENT OPTIONS #1 & 2, TERMINAL OPTIONS B & C)

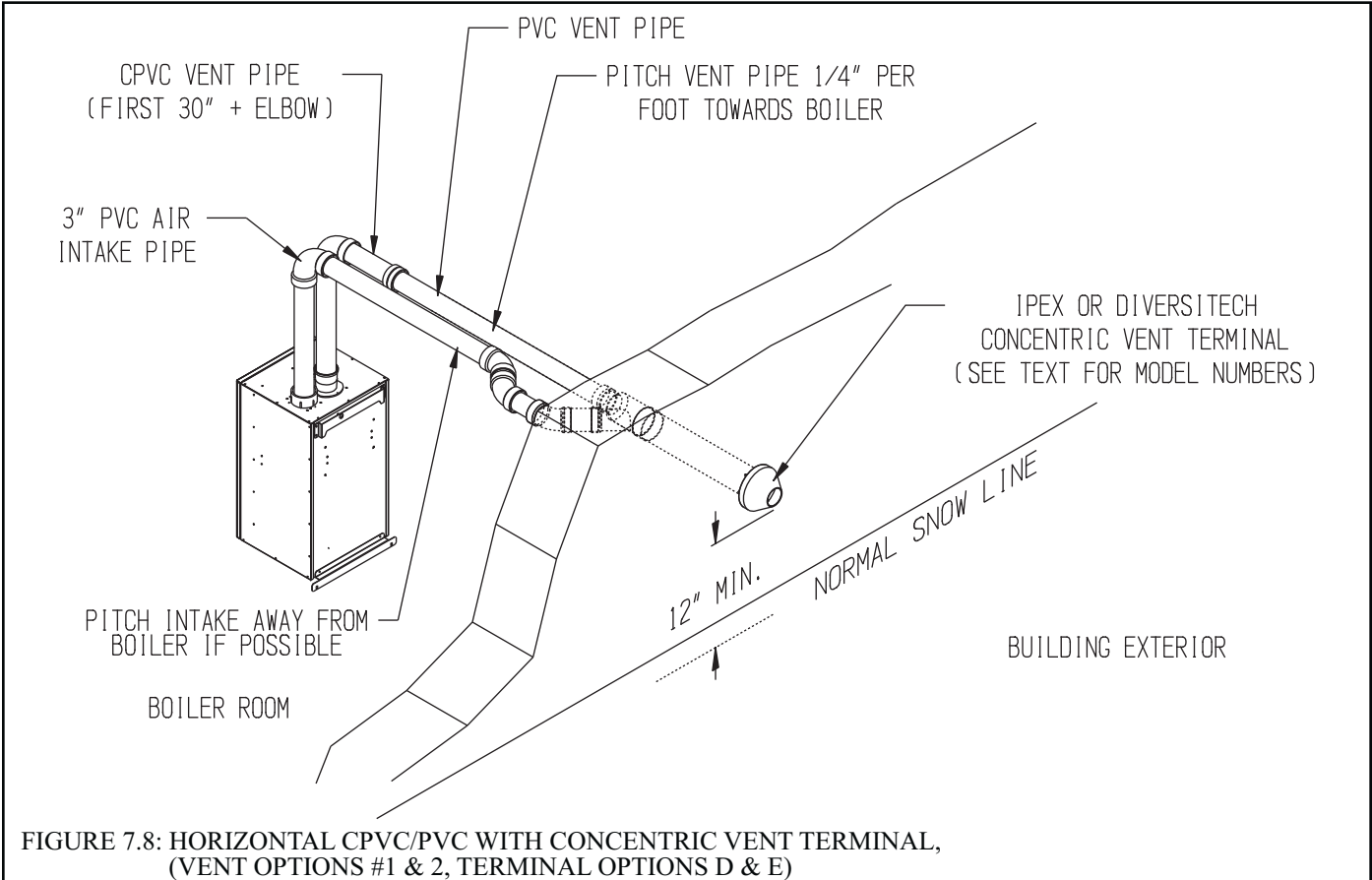

FIGURE 7.8: HORIZONTAL CPVC/PVC WITH CONCENTRIC VENT TERMINAL, (VENT OPTIONS #1 & 2, TERMINAL OPTIONS D & E)

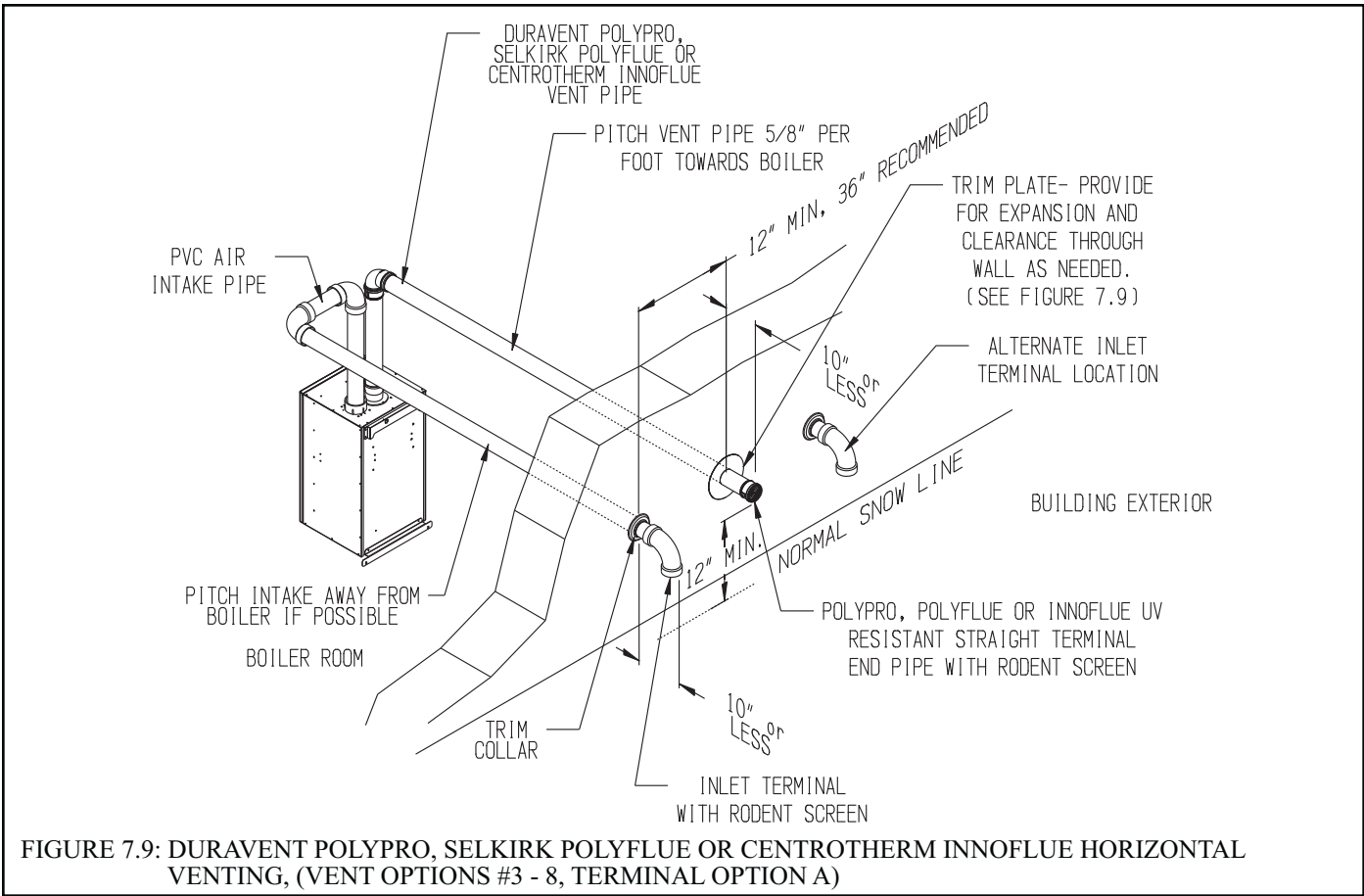

FIGURE 7.9: DURAVENT POLYPRO, SELKIRK POLYFLUE OR CENTROTHERM INNOFLUE HORIZONTAL VENTING, (VENT OPTIONS #3 - 8, TERMINAL OPTION A)

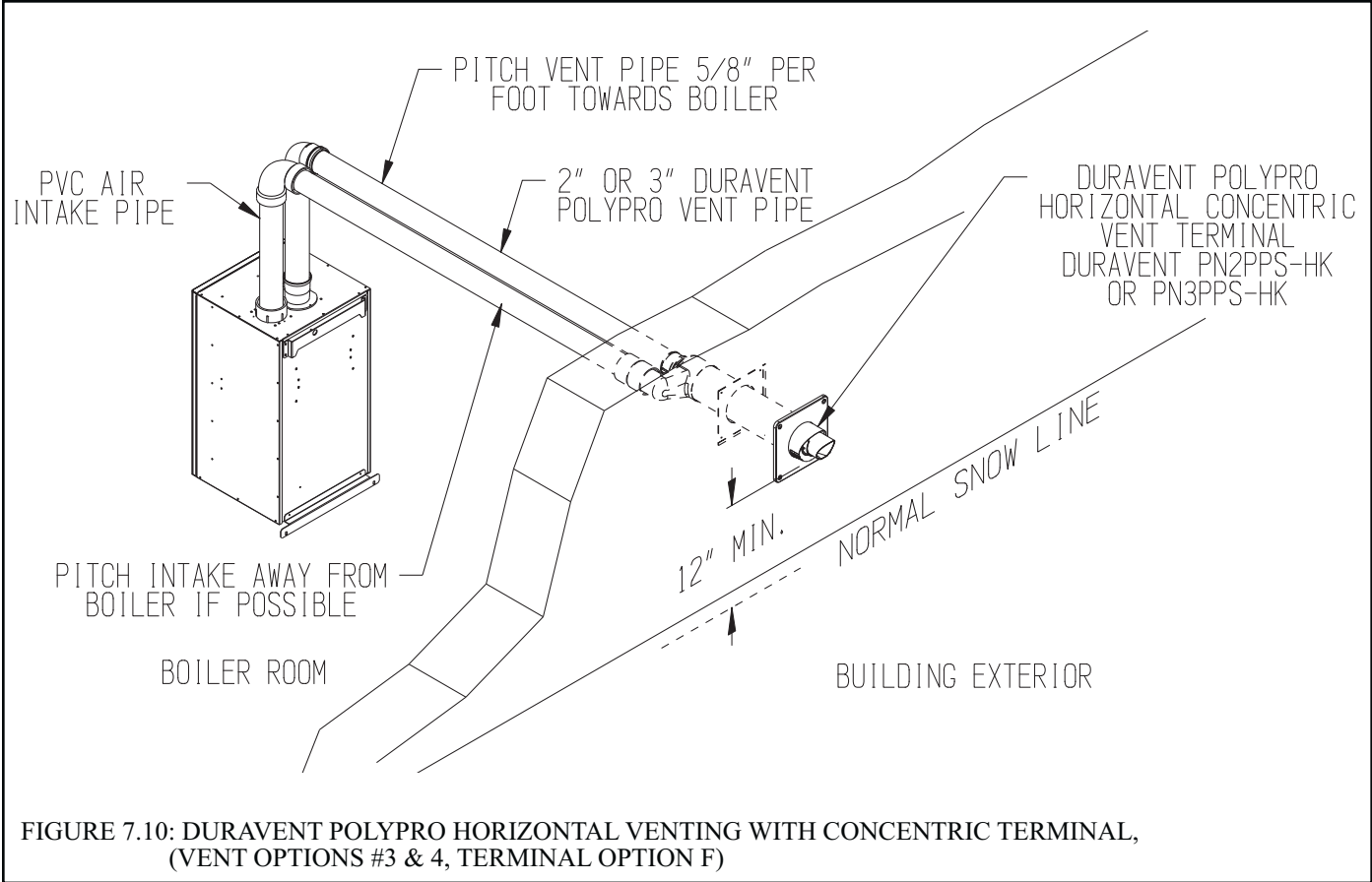
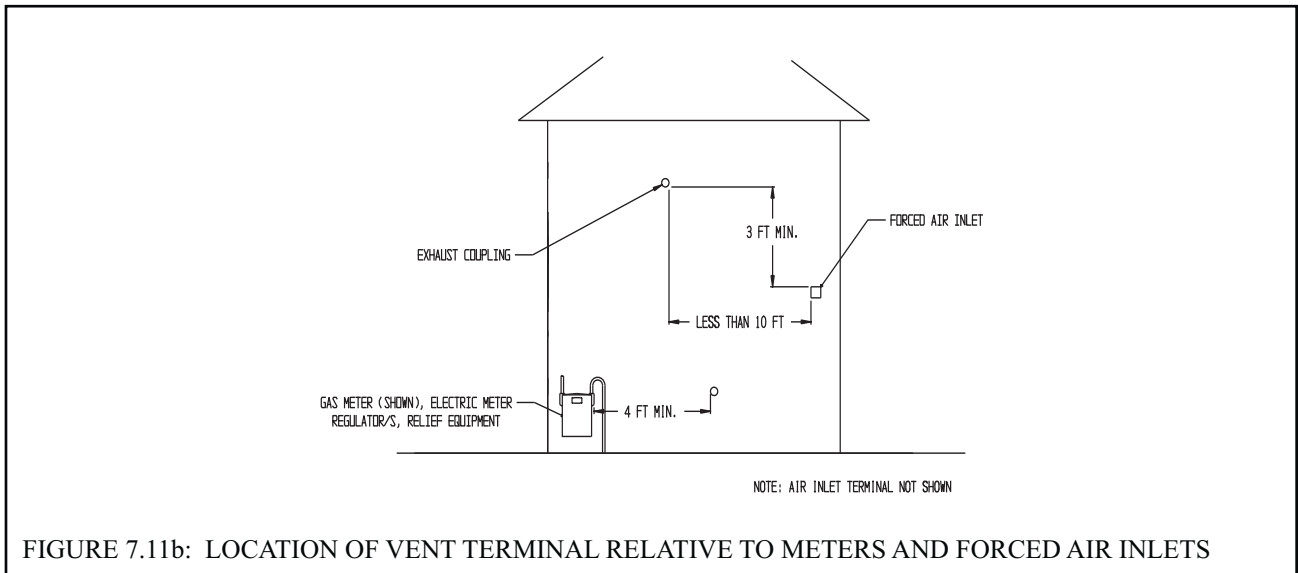
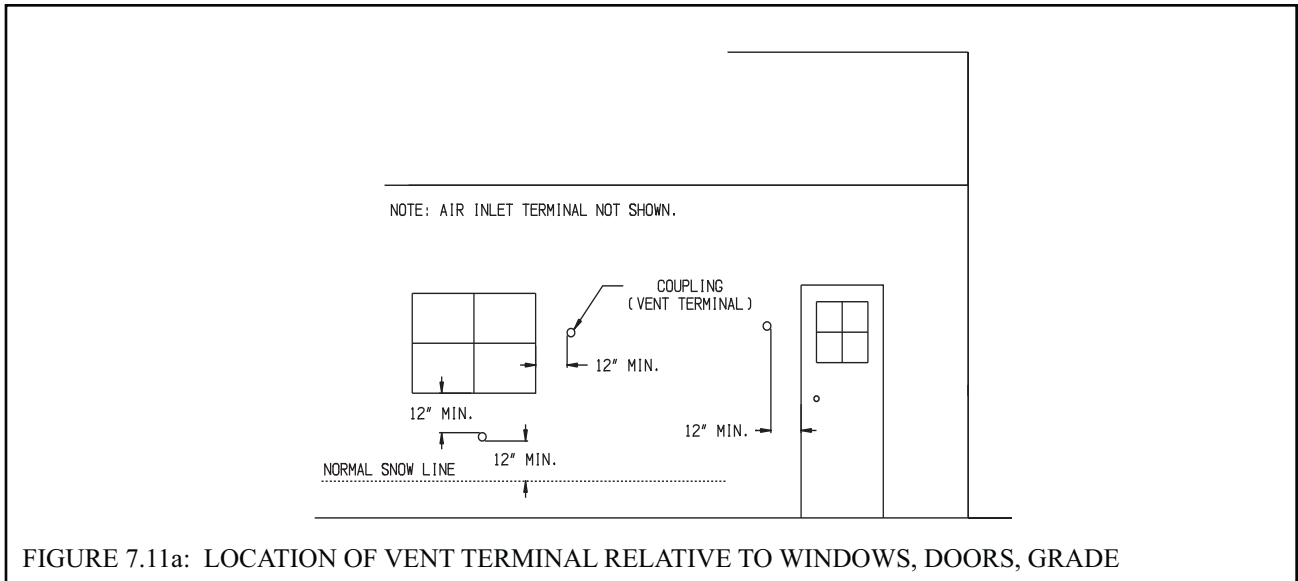

FIGURE 7.10: DURAVENT POLYPRO HORIZONTAL VENTING WITH CONCENTRIC TERMINAL, (VENT OPTIONS #3 & 4, TERMINAL OPTION F)



	Max. "X" (in.)	Min. "Y" (in.)
Ventilated Soffit	36	60
Unventilated Soffit or Other Overhang.	12	12
	18	24
	24	36
	30	48
	36	60

"X" May never exceed 36"

Example: For an unventilated 18" deep soffit, terminal must be at least 24" below soffit.

FIGURE 7.11c: POSITIONING VENT TERMINAL UNDER OVERHANGS

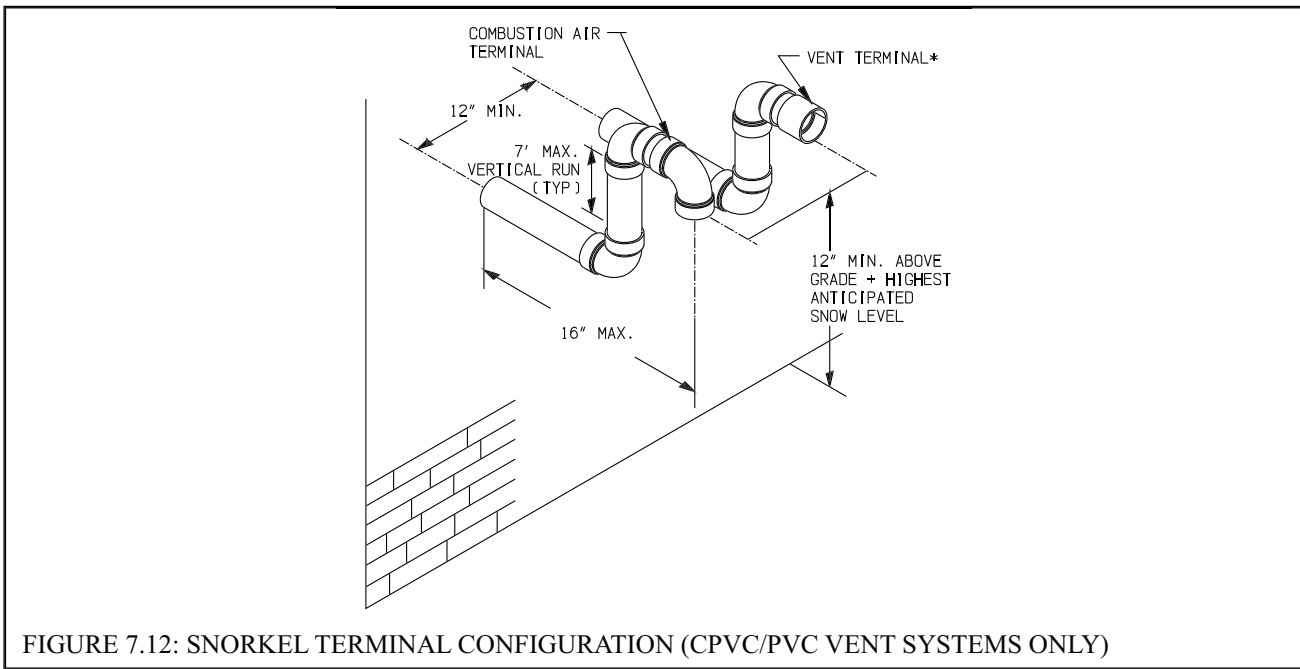

FIGURE 7.12: SNORKEL TERMINAL CONFIGURATION (CPVC/PVC VENT SYSTEMS ONLY)

### C. Design Requirements Unique to Vertical Venting Systems

Table 7.13a summarizes all vertical twin pipe vent options. Table 7.13.b summarizes vent options in which an abandoned B-vent chimney is used both as a chase for the vent pipe and as a conduit for combustion air.

In addition to the requirements in Part VII-A, observe the following design requirements:

#### 1. Permitted Terminals for Vertical Venting

**Terminal Option H: Fittings (Acceptable for Vent Options 10-17)** – Vent terminates in a plain end (coupling for PVC, bell end for Polypro, Polyflue and plain end pipe for InnoFlue). Intake terminates in a PVC 180 elbow pointing down (two sweep 90’s may be substituted). Observe the clearances from the roof, and normal snow line on the roof, shown in Figures 7.15 and 7.17. The section of Polypro, Polyflue or InnoFlue exposed to the outdoors must be UV resistant.

Use of rodent screens is generally recommended for both terminations. Two rodent screens suitable for 3” PVC terminals are supplied with the boiler and are installed as shown in Figure 7.29. If 2” CPVC is used, these screens can be cut to fit into the smaller fittings. Rodent screens (“bird guards”) for PolyPro, Polyflue and InnoFlue are as follows:

Size/Vent System	Rodent Screen (“Bird Guard”)
2” Polypro	DuraVent # 2PPS-BG
3” Polypro	DuraVent # 3PPS-BG
2” Polyflue	Selkirk # 2PF-HVST
3” Polyflue	Selkirk # 3PV-HVST
2” InnoFlue	Centrotherm # IASPP02
3” InnoFlue	Centrotherm # IASPP03

**Terminal Option I: Ipex FGV Concentric Terminal (Acceptable for Vent Options 10 & 11)** - This terminal is shown in Figure 7.16 and may be used with CPVC/PVC vent systems. Use a compatible roof flashing and storm collar in accordance with the Ipex instructions for this terminal. This terminal is available in various lengths and in both PVC and CPVC. Terminals acceptable for use with these vent options are as follows:

Ipex PN	FGV Concentric Terminal Description
196005	2 x 16” PVC
196105	2 x 28” PVC
196125	2 x 40” PVC
196006	3 x 20” PVC
196106	3 x 32” PVC
196116	3 x 44” PVC
197107	3 x 32” CPVC
197117	3 x 44” CPVC

See Part VII-E of this manual and the Ipex instructions provided with the terminal, for installation details.

Table 7.13a: Summary of Vertical Twin Pipe Venting Options

<b>Option</b>		<b>10</b>	<b>11</b>	<b>12</b>	<b>13</b>	<b>14</b>	<b>15</b>	<b>16</b>	<b>17</b>
Illustrated in Figure		7.15, 7.17	7.15, 7.17	7.17, 7.18	7.17, 7.18	7.17	7.17	7.17	7.17
Pipe Penetration through Structure	Vent	Roof	Roof	Roof	Roof	Roof	Roof	Roof	Roof
	Intake	Roof	Roof	Roof	Roof	Roof	Roof	Roof	Roof
Material	Vent	CPVC/ PVC (Note 2)	CPVC/ PVC (Note 2)	DuraVent PolyPro (Rigid)	DuraVent PolyPro (Rigid)	Selkirk Polyflue	Selkirk Polyflue	Centro- therm InnoFlue SW	Centro- therm InnoFlue SW
	Intake	PVC	PVC	PVC	PVC	PVC	PVC	PVC	PVC
Nominal Diameter	Vent	2"	3"	2"	3"	2"	3"	2"	3"
	Intake	2"	3"	2"	3"	2"	3"	2"	3"
Min Equivalent Vent Length:									
Models	080	12"	12"	12"	12"	12"	12"	12"	12"
	100	12"	12"	12"	12"	12"	12"	12"	12"
	120	Not Permitted	12"	Not Permitted	12"	Not Permitted	12"	Not Permitted	12"
	150		52"		52"		52"		
	180		52"		52"		52"		
Max Equivalent Vent Length (Note 1):									
Models	080	60ft	135ft	60ft	135ft	60ft	135ft	60ft	135ft
	100	60ft	135ft	60ft	135ft	60ft	135ft	60ft	135ft
	120	Not Permitted	135ft	Not Permitted	135ft	Not Permitted	135ft	Not Permitted	135ft
	150		135ft		135ft				
	180		135ft		135ft				
<b>Terminal Option H</b> (Fittings)	Vent	Coupling w Screen	Coupling w Screen	2PPS-12B or 2PPS-36B w Screen	3PPS-12B or 3PPS-36B w Screen	2PF-10UV or 2PF-39UV w Screen	3PF-10UV or 3PF-39UV w Screen	ISEP02 or ISEP0239 w Screen	ISEP03 or ISEP0339 w Screen
	Intake	180 Elbow w Screen	180 Elbow w Screen	180 Elbow w Screen	180 Elbow w Screen	180 Elbow w Screen	180 Elbow w Screen	180 Elbow w Screen	180 Elbow w Screen
<b>Terminal Option I</b> (Iplex FGV Concentric)		Iplex 196105 (Note 3)	Iplex 196006 (Note 3)	Not Permitted	Not Permitted	Not Permitted	Not Permitted	Not Permitted	Not Permitted
<b>Terminal Option J</b> (Diversitech CVENT Concentric)		CVENT-2	CVENT-3	Not Permitted	Not Permitted	Not Permitted	Not Permitted	Not Permitted	Not Permitted
<b>Terminal Option K</b> (DuraVent Vertical Concentric)		Not Permitted	Not Permitted	2PPS-VK	3PPS-VK	Not Permitted	Not Permitted	Not Permitted	Not Permitted

Notes:

- 1) Max vent lengths shown also apply to the intake. For example, Vent Option #1 may have up to 60ft of vent pipe and also up to 60 ft of intake pipe.
- 2) First 30" of vent and vent Elbow connected to boiler must be CPVC. Downstream vent pipe can be PVC except as noted in text.
- 3) Iplex FGV Concentric Terminal available in various lengths and also CPVC (see text).

**All vertical terminals require compatible roof flashing and storm collars.**

Table 7.13b: Summary of Vertical “B-Vent Air Chase” Vent Options  
(B-Vent Chase MUST Be Sealed)

Option		18	19	20	21
Illustrated in Figure		7.19	7.19	7.20	7.20
Pipe Penetration Through Structure	Vent	Roof	Roof	Roof	Roof
	Intake	Roof	Roof	Roof	Roof
Material	Vent	DuraVent PolyPro (Rigid/Flex)	DuraVent PolyPro (Rigid/Flex)	Centrotherm InnoFlue SW/Flex	Centrotherm InnoFlue SW/Flex
	Intake	B Vent/PVC	B Vent/PVC	B Vent/PVC	B Vent/PVC
Nominal Diameter	Vent	2”	3”	2”	3”
	Intake	2” or 3”	3”	2” or 3”	3”
Min B Vent ID		5”	6”	5”	6”
Min Equivalent Vent Length:					
Models	080	36”	36”	36”	36”
	100	36”	36”	36”	36”
	120		36”		36”
	150		52”		52”
	180		52”		52”
Max Equivalent Vent Length (Note 1):					
Models	080	60ft	135ft	60ft	135ft
	100	60ft	135ft	60ft	135ft
	120		135ft		135ft
	150		135ft		135ft
	180		135ft		135ft
Vent Manufacturer’s PN for Flex Termination/Components Required		2PPS-VFT 2PPS-BV* 2PPS-FLEX**	3PPS-VFT 3PPS-BV* 3PPS-FLEX**	IFBK02**** IAWP02B	IFBK03**** IAWP03B

\* Specify size of B vent (e.g. 2PPS-BV6 is for use with 6” B vent)

\*\* Specify length in feet.

\*\*\*\* Specify Flex length and B-vent diameter (e.g. IFBK022505 includes 25ft of flex and used with 5” B vent)

Note 1: Max vent lengths shown also apply to the intake. Flex vent reduces the maximum allowable vent length. See equivalent lengths for flex vent shown in Table 7.14 and sizing example on page 27.

### NOTICE

**Vertical venting and combustion air roof penetrations (where applicable) require the use of roof flashing and storm collar, which are not supplied with the boiler, to prevent moisture from entering the structure.**



Terminal Option J: Diversitech Concentric Terminal (Acceptable for Vent Options 10 & 11) - This terminal is shown in Figure 7.16 and may be used with CPVC/PVC vent systems. See Part VII-E of this manual and the Diversitech instructions provided with the terminal, for installation details.

Terminal Option K: DuraVent PolyPro Concentric Terminal (Acceptable for Vent Options 12, 13) - This terminal is shown in Figure 7.18 and may be used with DuraVent 2" or 3" PolyPro vent systems. Use a compatible DuraVent roof flashing and storm collar in accordance with the DuraVent instructions for this terminal. See Part VII-F of this manual and the DuraVent instructions provided with the terminal, for installation details.

2. Vertical Vent and Air Intake Location – Observe the following clearances from roof mounted terminals:
  - Bottom of air intake opening must be at least 12" above the normal snow line anticipated on the roof.
  - Exhaust opening must be at least 2ft above any portion of the roof or structure located within horizontally within 10ft.
  - For terminal option H, maintain at least 12" of vertical separation between the exhaust and intake opening as shown in Figure 7.15 and 7.17.
3. Requirements for B-Vent Air Chase Options – Observe the following additional requirements when using an abandoned B-vent chimney as an air chase as described in Options #18-21. Also refer to Figures 7.19 & 7.20.
  - B vent must be clean and in good condition.
  - Use of flex polypropylene outside of B-vent chimney is not permitted.
  - All joints and seams in the B-vent must be sealed with RTV. If these seams are not accessible, vent options 18-21 cannot be used while complying with the National Fuel Gas Code (as an alternative, the B-vent chimney can be used as a chase for the vent pipe while combustion air is piped from an outside wall - see Part VII-D for additional details).
  - All venting is polypropylene supplied by the vent manufacturer shown in Table 7.13b. The portion of this venting within the B-vent is flexible.
  - All flex pipe must be installed vertically. Up to two offsets (four bends) may be made in the vertical run of flex pipe. Bends used to make these offsets may not exceed 45 degrees.
  - Because the flex pipe is corrugated, it has a higher pressure drop than the rigid pipe used elsewhere in the vent system. Equivalent lengths for flex venting are shown in Table 7.14. Reduce the maximum allowable vent length shown in Table 7.13b by this equivalent length for each foot of flex pipe used, as well as for each elbow in addition to the first. The termination is not counted. If offsets (described above) are present, the equivalent length of the bends in these offsets can also be ignored.

*Example: A 100MBH model is to be installed as using Vent Option 18 as shown in Figure 7.19. The following components are used:*

*Vent:*

*2" DuraVent Poly-Pro (Rigid) – 4ft*

*2" DuraVent Poly-Pro Flex – 20ft*

*Poly-Pro elbows – 2*

*DuraVent 2PPS-VFT Terminal (exhaust side)*

*Intake:*

*2" PVC – 6ft*

*2" PVC Sweep 90 – 3*

*Turn in B vent Tee*

*Straight B-vent (5" or larger) containing flex vent – 20ft*

*DuraVent 2PPS-VFT Terminal (intake side)*

*Vent Equivalent length – First elbow is ignored. The terminal is also ignored. From Table 7.14, the equivalent length of 2" DuraVent Poly-Pro Flex is 2.0ft. From Table 7.1 the equivalent length of the second 90 elbow is 4.5ft. The equivalent length of the vent system is therefore:*

$$4 + 4.5 + (20 \times 2.0) = 48.5\text{ft.}$$

*Since Vent Option 18 shows a max vent length of 60ft, the planned vent length of OK.*

*Intake Equivalent length - First elbow and the turn in the B vent tee are ignored, leaving two sweep 90 elbows that must be counted. From Table 7.1, the equivalent length of each of these elbows is 2.6ft. From Table 7.14 the equivalent length of the B vent containing flex is 1.0ft. Equivalent length of the intake system is therefore:*

$$(2 \times 2.6) + 6 + (20 \times 1.0) = 31.2\text{ft.}$$

*Since this is less than 60ft, the planned intake length is OK.*

Table 7.14: Equivalent Length of Flex Pipe

	Equivalent Length (ft)
Flex Vent (1 ft):	
2" DuraVent PolyPro Flex	2.0 ft
2" Centrotherm Innoflue Flex	2.0 ft
2" Selkirk Polyflue	2.0 ft
3" DuraVent PolyPro Flex	2.0 ft
3" Centrotherm Innoflue Flex	2.3 ft
3" Selkirk Polyflue	2.3 ft
B-Vent Air Chase (1ft):	
2" Flex Vent in 5" (or larger) B-Vent	1.0 ft
3" Flex Vent in 6" (or larger) B-Vent	1.0 ft

Note: Up to four 45 degree bends may be made in flex pipe or air chase. These bends are not counted when figuring equivalent length.

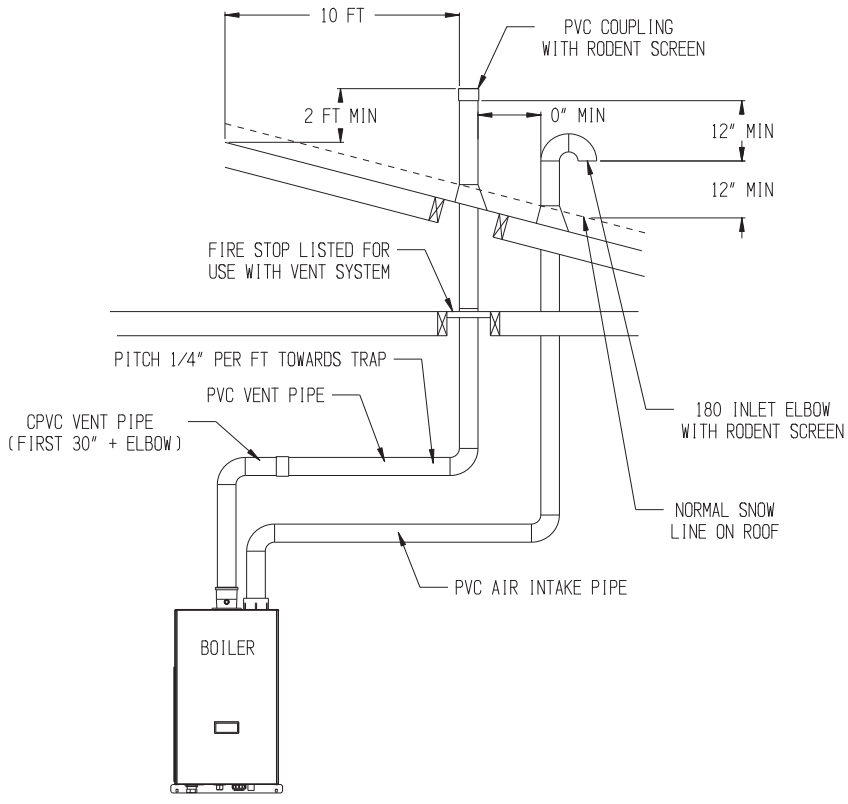

FIGURE 7.15: VERTICAL CPVC/PVC VENTING, (VENT OPTIONS 10 & 11, TERMINAL OPTION H)

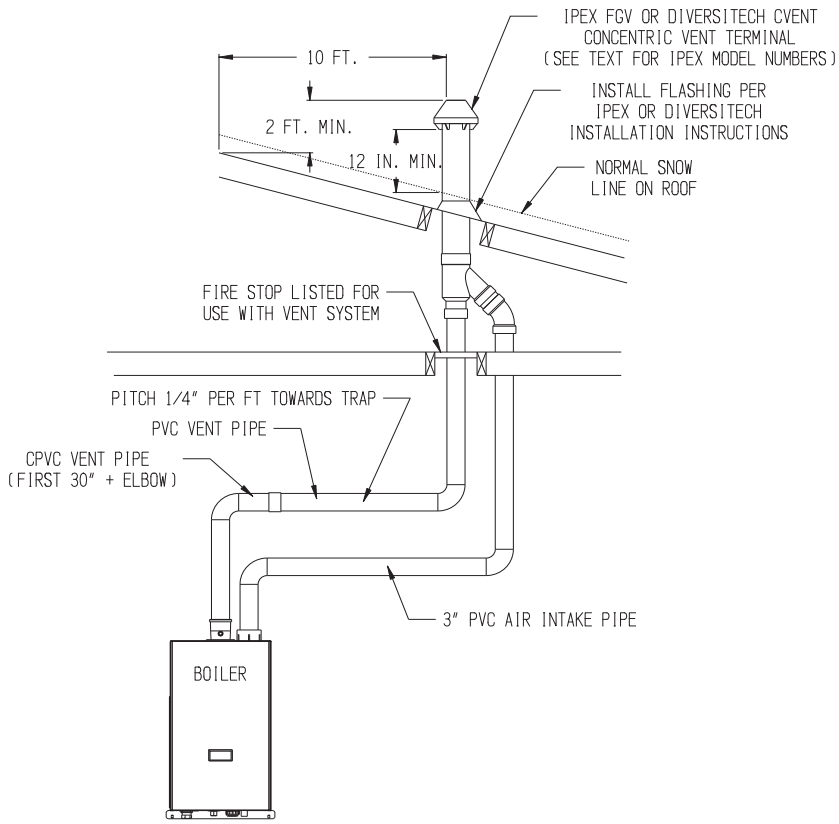

FIGURE 7.16: VERTICAL CPVC/PVC VENTING WITH IPEX CONCENTRIC VENT TERMINAL, (VENT OPTIONS #10 & 11, TERMINAL OPTIONS I, J)

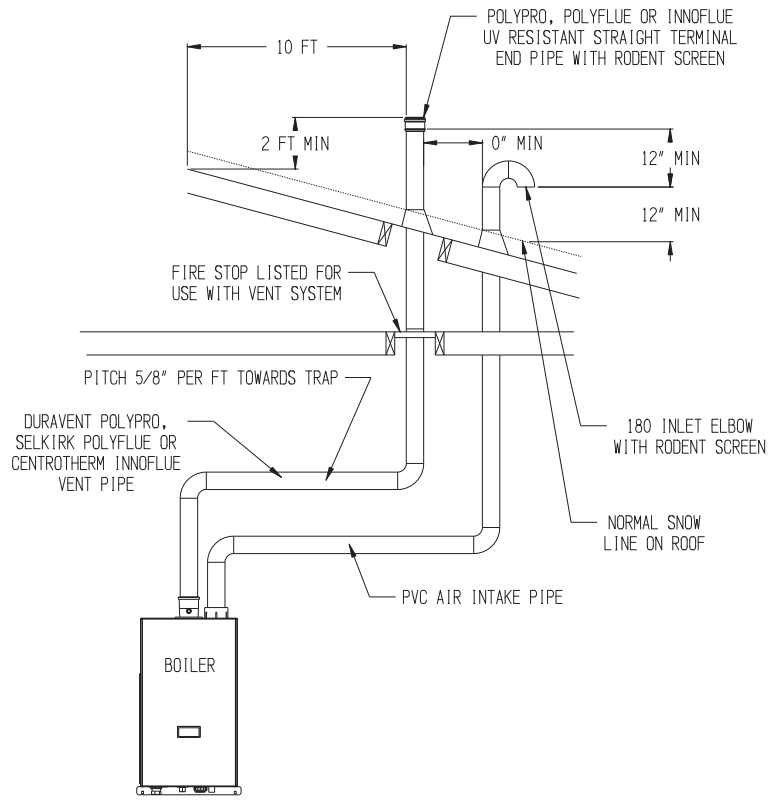

FIGURE 7.17: DURAVENT POLYPRO, SELKIRK POLYFLUE OR CENTROTERM INNOFLUE VERTICAL SINGLE WALL PP VENTING, (VENT OPTIONS #12-17, TERMINAL OPTION A)

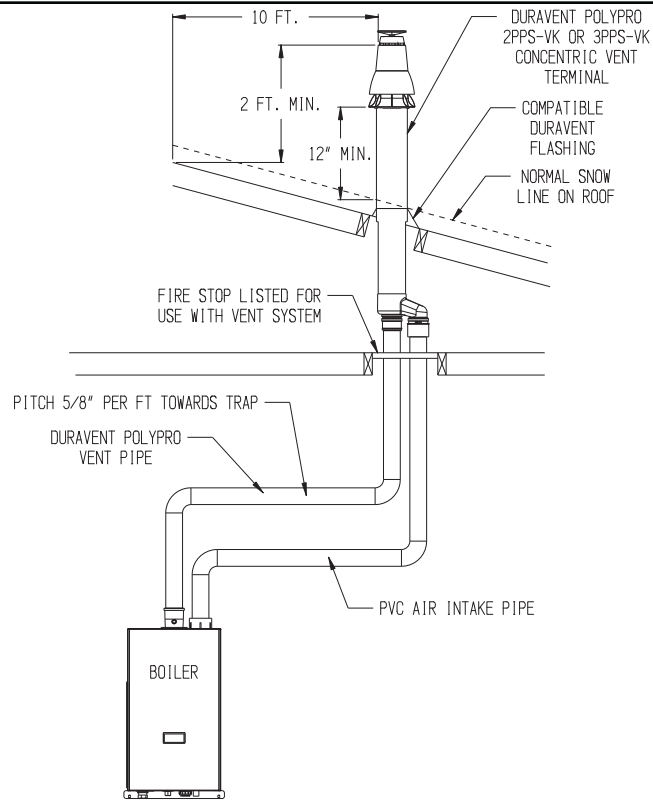

FIGURE 7.18: DURAVENT POLYPRO VERTICAL VENTING WITH CONCENTRIC TERMINAL, (VENT OPTIONS #12 & 13, TERMINAL OPTION K)

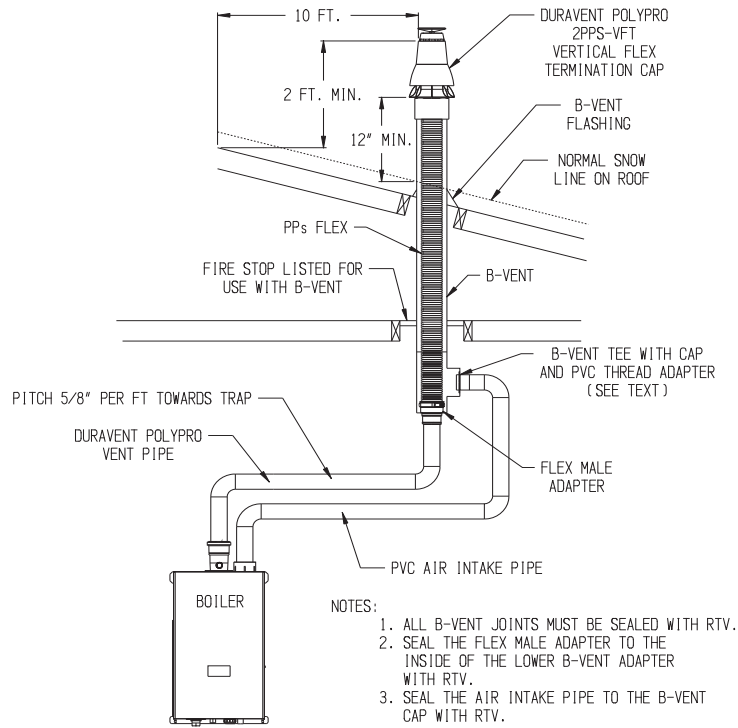

FIGURE 7.19: DURAVENT POLYPRO B-VENT AIR CHASE SYSTEM (VENT OPTIONS #18 & 19)

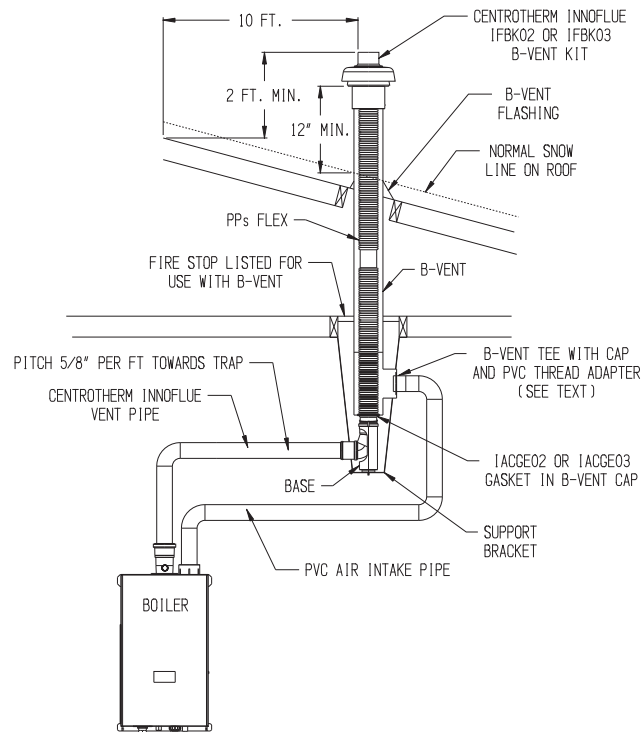

FIGURE 7.20: CENTROTHERM INOFLUE B-VENT AIR CHASE SYSTEM (VENT OPTIONS #20 & 21)

## D. Design Requirements Unique to Split Vent Systems

Table 7.21 summarizes all split vent options. Illustrations of split vent systems are shown in Figures 7.22, 7.23, and 7.24. In addition to the requirements in Part VII-A, observe the following design requirements:

### 1. Permitted Terminals for Split Venting:

**Rigid Vent Systems (Vent Options 25-32)** – Vent terminates in a plain end (coupling for PVC, bell end for Polypro, Polyflue, and plain end pipe for InnoFlue). Intake terminates in a PVC 90 sweep elbow pointing down. The section of Polypro, Polyflue or InnoFlue exposed to the outdoors must be UV resistant.

Use of a rodent screen is generally recommended for the vent termination. A rodent screen suitable for 3” PVC terminals is supplied with the boiler and is installed under the termination coupling as shown in Figure 7.28. If 2” CPVC is used, this screen can be cut to fit into the smaller fitting. Rodent screens (“bird guards”) for PolyPro, Polyflue and InnoFlue are as follows:

Size/Vent System	Rodent Screen (“Bird Guard”)
2” Polypro	DuraVent # 2PPS-BG
3” Polypro	DuraVent # 3PPS-BG
2” Polyflue	Selkirk #2PF-HVST
3” Polyflue	Selkirk #2PF-HVST
2” InnoFlue	Centrotherm # IASPP02
3” InnoFlue	Centrotherm # IASPP03

**Flex Vent Terminals (Options 33-38)** – The flex vent kits shown for options 33-38 include vent terminals that must be installed in accordance with the vent manufacturer’s instructions. Different terminals are used for Masonry and B-vent chimney chases.

**Air Intake Terminals (Vent Options 25-38)** - All split venting options shown in Tables 7.21 terminate in a PVC 90 sweep elbow pointing down. Use of a rodent screen is generally recommended for the intake termination. A rodent screen suitable for 3” PVC terminals is supplied with the boiler and is installed under the intake termination elbow coupling as shown in Figure 7.28. If 2” CPVC is used, this screen can be cut to fit into the smaller fitting.

### 2. Vent Terminal Location – Observe the following clearances from roof mounted vent terminals (also see Figures 7.22, 7.23, or 7.24):

- Bottom of terminal must be at least 12” above the normal snow line anticipated on the roof.
- Exhaust opening must be at least 2ft above any portion of the roof or structure located within horizontally within 10ft.

### 3. Horizontal Air Intake Terminal Location - Observe the following limitations on the intake terminal location (also see Figures 7.22, 7.23, or 7.24):

- The bottom of all terminals must be at least 12” above the normal snow line. In no case should they be less than 12” above grade level.
- If possible, install the intake terminal on a wall away from the prevailing wind. Reliable operation of this boiler cannot be guaranteed if the intake terminal is subjected to winds in excess of 40 mph.
- Air intake terminal must not terminate in areas that might contain combustion air contaminants, such as near swimming pools. See WARNING on page 12.

### 4. Use of abandoned chimneys as a vent chase (Options 33-38) – Vent options 33-38 permit flexible polypropylene venting to be routed to the roof using an abandoned masonry or B- vent chimney. In these applications combustion air is drawn horizontally from a wall terminal. See Figure 7.23 or 7.24. When using one of these vent options, observe the following requirements:

- When a masonry chimney containing multiple flues is used as a chase, ALL flues must be abandoned (Figure 7.26).
- Masonry or B vent chimney used as a chase must be structurally sound.
- Use of flex polypropylene outside of a masonry or B-vent chimney is not permitted unless allowed by the vent manufacturer and permitted by local codes.
- All venting is polypropylene supplied by the vent manufacturer shown in Table 7.21. The portion of this venting within the masonry or B-vent chimney is flexible.
- All flex pipe must be installed vertically. Up to two offsets (four bends) may be made in the vertical run of flex pipe. Bends used to make these offsets may not exceed 45 degrees (Figure 7.25).
- Because the flex pipe is corrugated, it has a higher pressure drop than the rigid pipe used elsewhere in the vent system. Equivalent lengths for flex venting are shown in Table 7.14. Reduce the maximum allowable vent length shown in Table 7.21 by this equivalent length for each foot of flex pipe used, as well as for each elbow in addition to the first. The first elbow and termination are not counted. If offsets (described above) are present, the equivalent length of the bends in these offsets can also be ignored.

*Example: A 100MBH model is to be installed as using Vent Option 34 in a masonry chimney as shown in Figure 7.23. The following components are used:*

*Vent:*

*3" DuraVent Poly-Pro (Rigid) – 4ft*

*3" DuraVent Poly-Pro Flex – 30ft*

*Poly-Pro elbows – 2 (one at base of chimney and one above boiler)*

*DuraVent 3PPS-FK Terminal*

*Intake:*

*3" PVC – 6ft*

*3" PVC Sweep 90 – 2 (one above the boiler and one as an intake terminal)*

*Vent Equivalent length – First elbow is ignored. The terminal is also ignored. From Table 7.14, the equivalent length of 3" DuraVent Poly-Pro Flex is 2.0ft. From Table 7.1 the equivalent length of the second 90 elbow is 8.7ft. The equivalent length of the vent system is therefore:*

$$4 + 8.7 + (30 \times 2.0) = 72.7\text{ft.}$$

*Since Vent Option 34 shows a max vent length of 135ft, the planned vent length of OK.*

*Intake Equivalent length - First elbow and termination elbow are ignored, leaving just the straight pipe. Equivalent length of the intake system is therefore 6ft. Since this is less than 135ft, the planned intake length is OK.*



## **WARNING**

- **Flex Vent Options may only be used in unused chimneys**
- **When a Masonry chimney is used as a chase, ALL flues in that chimney must be unused.**

**Failure to observe the above requirements could cause flue gas to enter the building, resulting in severe property damage, personal injury, or loss of life.**

Table 7.21: Summary of Split Vent System Options

Option #		25	26	27	28	29	30
Illustrated in Figure		7.22	7.22	7.22	7.22	7.22	7.22
Pipe Penetration Through Structure	Vent	Roof	Roof	Roof	Roof	Roof	Roof
	Intake	Wall	Wall	Wall	Wall	Wall	Wall
Material	Vent	CPVC/PVC (Note 2)	CPVC/PVC (Note 2)	DuraVent PolyPro (Ridgid)	DuraVent PolyPro (Ridgid)	Selkirk Polyflue	Selkirk Polyflue
	Intake	PVC	PVC	PVC	PVC	PVC	PVC
Nominal Diameter	Vent	2"	3"	2"	3"	2"	3"
	Intake	2" or 3"	3"	2" or 3"	3"	2" or 3"	3"
Min Equivalent Vent Length:							
Models	080	48"	48"	48"	48"	48"	48"
	100	48"	48"	48"	48"	48"	48"
	120		48"		48"		48"
	150		52"		52"		52"
	180		52"		52"		52"
Max Equivalent Vent Length (Note 1):							
Models	080	60ft	135ft	60ft	135ft	60ft	135ft
	100	60ft	135ft	60ft	135ft	60ft	135ft
	120		135ft		135ft		135ft
	150		135ft		135ft		135ft
	180		135ft		135ft		135ft
Rigid Vent Terminals	Vent	Coupling w Screen	Coupling w Screen	2PPS-12B or 2PPS-36B w Screen	3PPS-12B or 3PPS-36B w Screen	2PF-10UV or 2PF-39UV w Screen	3PF-10UV or 3PF-39UV w Screen
	Intake	90 Elbow w Screen	90 Elbow w Screen	90 Elbow w Screen	90 Elbow w Screen	90 Elbow w Screen	90 Elbow w Screen
Flex Termination & Components (Masonry Chimney Chase) (Note 3)	Vent						
	Intake						
Flex Termination & Components (B-Vent Chimney Chase)	Vent						
	Intake						

\* Specify size of B vent (e.g. 2PPS-BV6 is for use with 6" B vent)

\*\* Specify length in feet.

\*\*\*\* Specify Flex length and B vent diameter (e.g. IFBK022505 includes 25ft of flex and used with 5" B vent)

Note 1: Max vent lengths shown also apply to the intake. Flex vent reduces the maximum allowable vent length.

See equivalent lengths for flex vent shown in Table 7.14 and sizing example on page 27.

Note 2: First 30" plus first exhaust elbow are CPVC.

Note 3: If masonry chimney contains flues in addition to that being used for chase, **ALL** must be unused.

Note 4: See Polyflue installation manual for gaskets, spacers and other required vent components.

**All vertical terminals require compatible roof flashing and storm collars.**



Table 7.21: Summary of Split Vent System Options (cont.)

31	32	33	34	35	36	37	38
7.22	7.22	7.23, 7.24	7.23, 7.24	7.23, 7.24	7.23, 7.24	7.23, 7.24	7.23, 7.24
Roof	Roof	Roof	Roof	Roof	Roof	Roof	Roof
Wall	Wall	Wall	Wall	Wall	Wall	Wall	Wall
Centrotherm InnoFlue SW	Centrotherm InnoFlue SW	DuraVent PolyPro (Rigid/Flex)	DuraVent PolyPro (Rigid/Flex)	Selkirk Polyflue (Rigid/Flex)	Selkirk Polyflue (Rigid/Flex)	Centrotherm Innoflue (Rigid/Flex)	Centrotherm Innoflue (Rigid/Flex)
PVC	PVC	PVC	PVC	PVC	PVC	PVC	PVC
2"	3"	2"	3"	2"	3"	2"	3"
2" or 3"	3"	2" or 3"	3"	2" or 3"	3"	2" or 3"	3"
Min Equivalent Vent Length:							
48"	48"	48"	48"	48"	48"	48"	48"
48"	48"	48"	48"	48"	48"	48"	48"
	48"		48"		48"		48"
	52"		52"		52"		52"
	52"		52"		52"		52"
Max Equivalent Vent Length (Note 1):							
60ft	135ft	60ft	135ft	60ft	135ft	60ft	135ft
60ft	135ft	60ft	135ft	60ft	135ft	60ft	135ft
	135ft		135ft		135ft		135ft
	135ft		135ft		135ft		135ft
	135ft		135ft		135ft		135ft
ISEP02 or ISEP0239 w Screen	ISEP03 or ISEP0339 w Screen						
90 Elbow w Screen	90 Elbow w Screen						
		2PPS-FK 2PPS-FLEX**	3PPS-FK 3PPS-FLEX**	2PF-FLEX-KIT 2PF-FLEX	3PF-FLEX-KIT 3PF-FLEX	IFCK02**	IFCK03**
		90 Elbow w Screen	90 Elbow w Screen	90 Elbow w Screen	90 Elbow w Screen	90 Elbow w Screen	90 Elbow w Screen
		2PPS-VFT 2PPS-BF* 2PPS-FLEX**	3PPS-VFT 3PPS-BF* 3PPS-FLEX**	2PF-10UV or 2PF-39UV w Screen 2PF-BVSC (Note 4)	3PF-10UV or 3PF-39UV w Screen 3PF-BVSC (Note 4)	IFBK02****	IFBK03****
		90 Elbow w Screen	90 Elbow w Screen	90 Elbow w Screen	90 Elbow w Screen	90 Elbow w Screen	90 Elbow w Screen

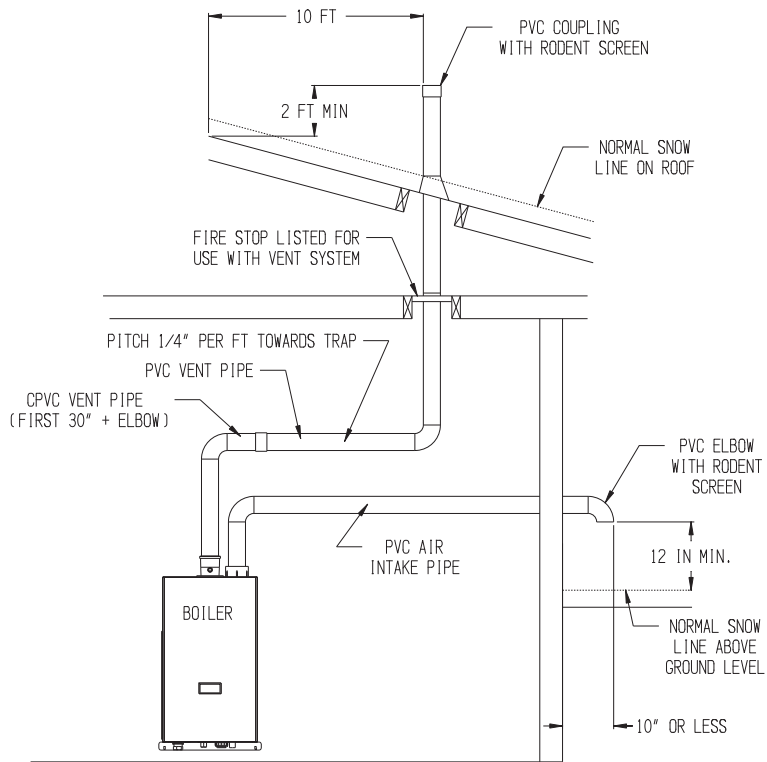

FIGURE 7.22: SPLIT RIGID VENT SYSTEM (VENT OPTIONS 25-32 - CPVC SYSTEM SHOWN IN ABOVE EXAMPLE)

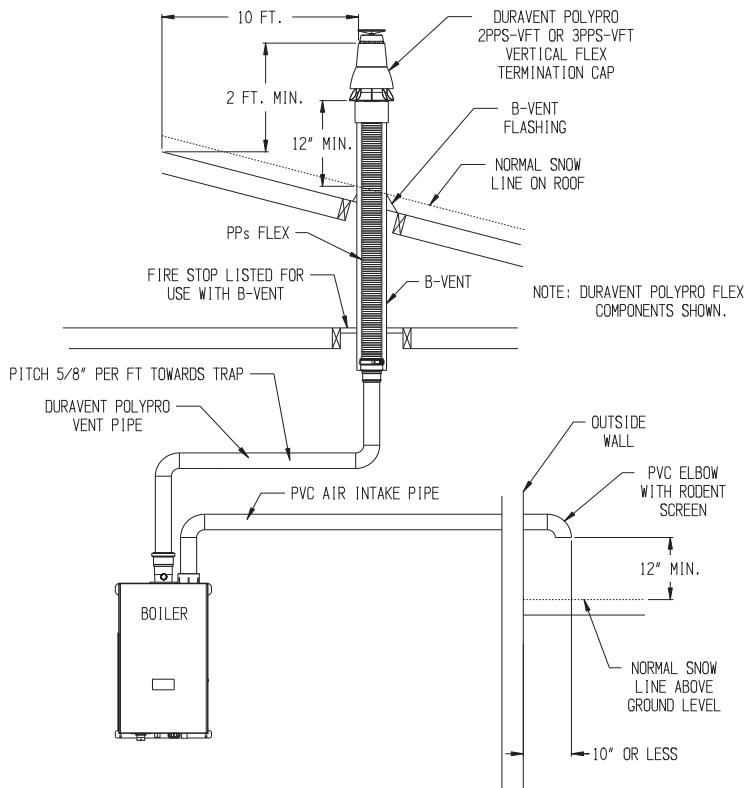

FIGURE 7.23: SPLIT VENT SYSTEM (FLEX IN B-VENT CHASE)(VENT OPTIONS 33-38)

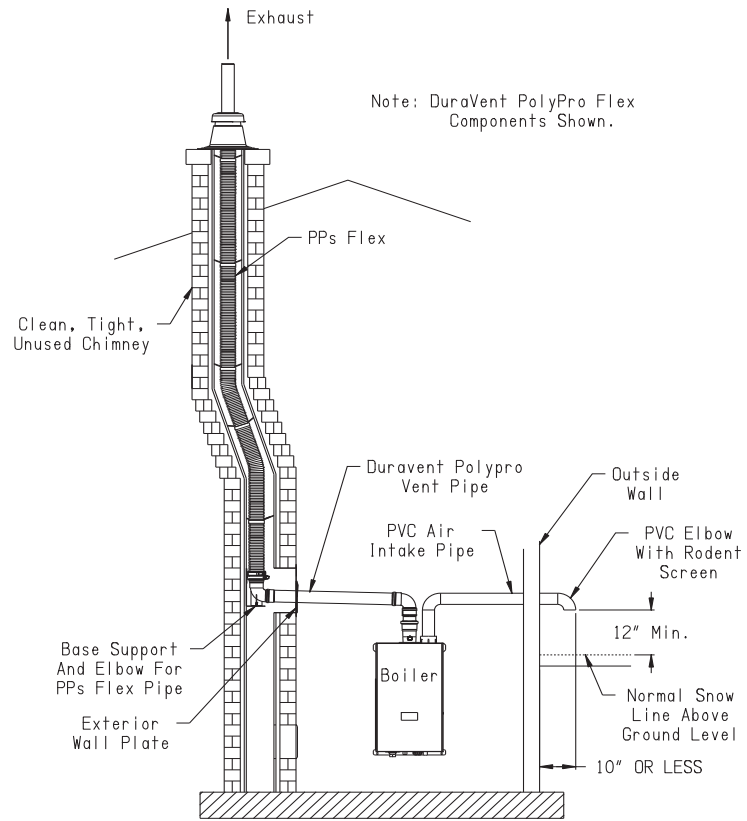

FIGURE 7.24: SPLIT VENT SYSTEM (FLEX IN ABANDONED MASONRY CHIMNEY)(VENT OPTIONS 33-38)

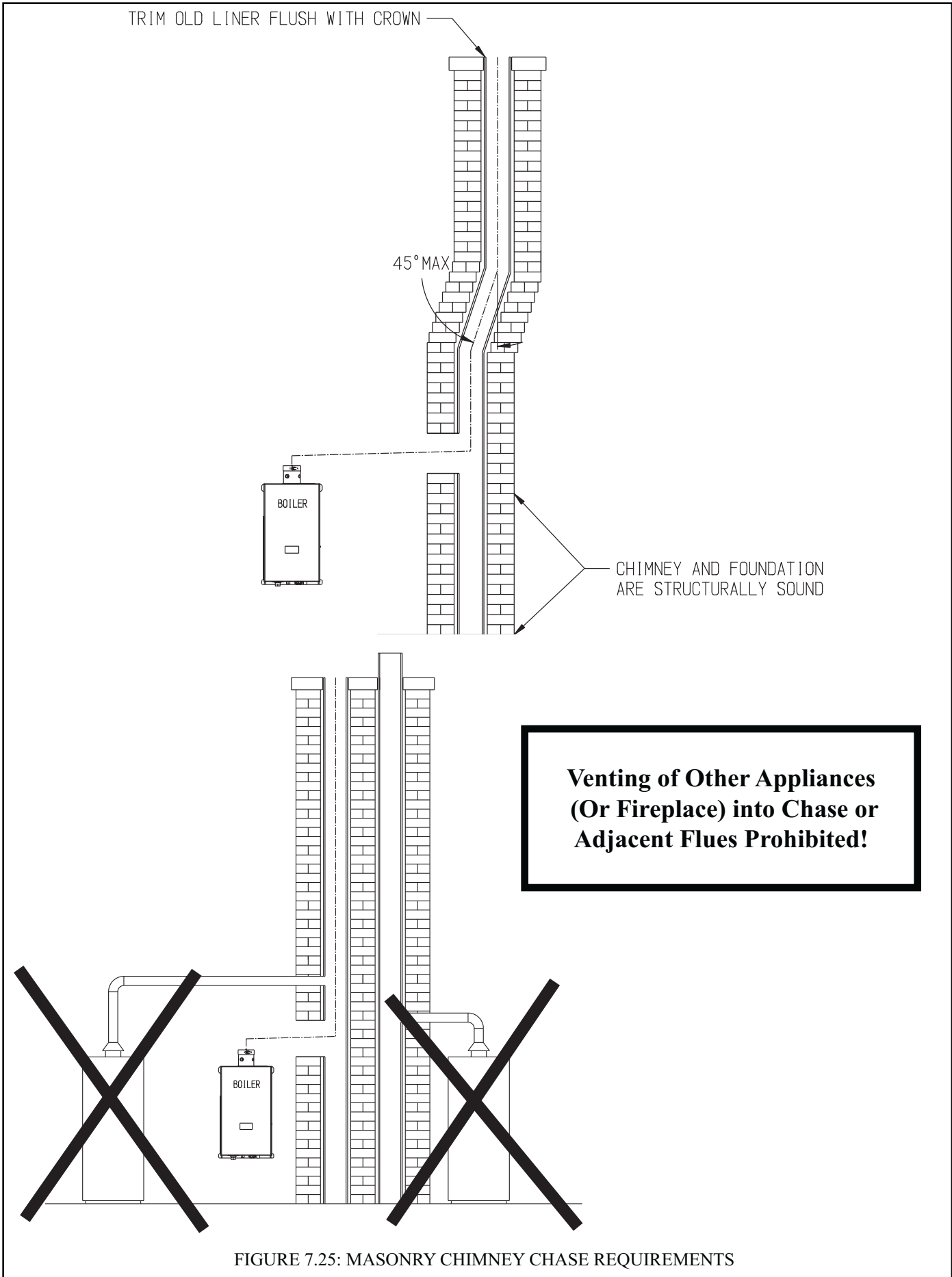

FIGURE 7.25: MASONRY CHIMNEY CHASE REQUIREMENTS

## E. Assembly of CPVC/PVC Vent Systems



### WARNING

- **Asphyxiation Hazard.** Failure to follow these instructions could cause products of combustion to enter the building, resulting in severe property damage, personal injury, or death.
- Use all CPVC vent components (supplied with the boiler) for near-boiler vent piping before transitioning to Schedule 40 PVC pipe (ASTM 2665) components for remainder of vent system.
- Use CPVC vent components within any interior space where air cannot circulate freely, including through vertical or horizontal chase ways, inside a stud wall, in closets and through wall penetrations.
- The use of cellular core PVC (ASTM F891), cellular core CPVC or Radel (polyphenolsulfone) is prohibited.
- All condensate that forms in the vent must be able to drain back to the boiler.
- Never leave the boiler in operation without the gas sample cap in place (Figure 7.27)

1. The components shown in Table 7.26 are supplied with this boiler for use in a 3” CPVC/PVC vent system. PVC piping must be supplied by the installer for the air intake pipe and any venting beyond the first 30”.

TABLE 7.26: CPVC/PVC VENT KIT COMPONENTS

QUANTITY	DESCRIPTION	SIZE
1	30” STRAIGHT CPVC PIPE	3”
1	CPVC ELBOW	3”
1	PVC COUPLING TERMINATION	3”
1	PVC 90° ELBOW TERMINATION	3”
2	RODENT SCREEN	3”

2. Assemble the vent system, starting at the boiler:
  - a. If 3” PVC is to be used for venting, the 3” CPVC elbow and the 30” straight section of CPVC provided with the boiler must be used before transitioning to PVC. If necessary the 30” straight section of CPVC may be cut in any location and the CPVC elbow inserted between the two resulting segments.
  - b. When cutting CPVC or PVC pipe, use a miter saw or a saw designed to cut PVC pipe. Use a miter box or other method to cut pipe squarely. De-burr both the inside and outside of the cut end.
  - c. Dry fit all vent components before assembly.
  - d. The vent adaptor has two different inside diameters. The larger (upper) inside diameter accepts 3” CPVC pipe and is used in this application (the smaller, lower, inside diameter accepts 3” nominal Polypro, Polyflue or InnoFlue). A locking ring in the adaptor prevents the vent pipe from coming out of the adaptor once it is inserted. Lubricate the upper gasket in the vent adaptor with water and insert the first piece of 3” CPVC into the vent adaptor until it bottoms out.

### NOTICE

**Once a vent pipe is inserted into this adaptor, it is IMPOSSIBLE to remove it. Make sure the correct type of pipe is selected, and that it is of the correct length, before inserting it into the vent adaptor.**

- e. If 2” CPVC is to be used for the vent system, reduce the first piece of 3” CPVC installed in Step (b) to 2” CPVC using a CPVC reducing coupling or elbow. Otherwise assemble the 3” CPVC elbow and the remainder of the 30” CPVC piping before transitioning to PVC. If 3” PVC is used, the first piece of PVC will either be connected to the CPVC elbow supplied with the boiler, or the end of a section of CPVC vent pipe. In the latter case, a PVC coupling may be used to connect the first piece of PVC to the last piece of CPVC.
- f. Clean all CPVC and PVC components with the appropriate primer before cementing. Cement the vent system together, starting at the boiler and following the instructions provided on the cans of cement and primer. Use a field supplied cement and primer that is listed for use with the materials being joined (CPVC and/or PVC). The following, or its equivalent, may be used to join CPVC to PVC:
  - IPS Corporation #P-70 Primer
  - IPS Corporation #790 Multi-Purpose Solvent Cement

Always use primer on both the pipe and fitting before applying the cement. Assemble the pipe in accordance with the instructions on the cans of primer and cement.

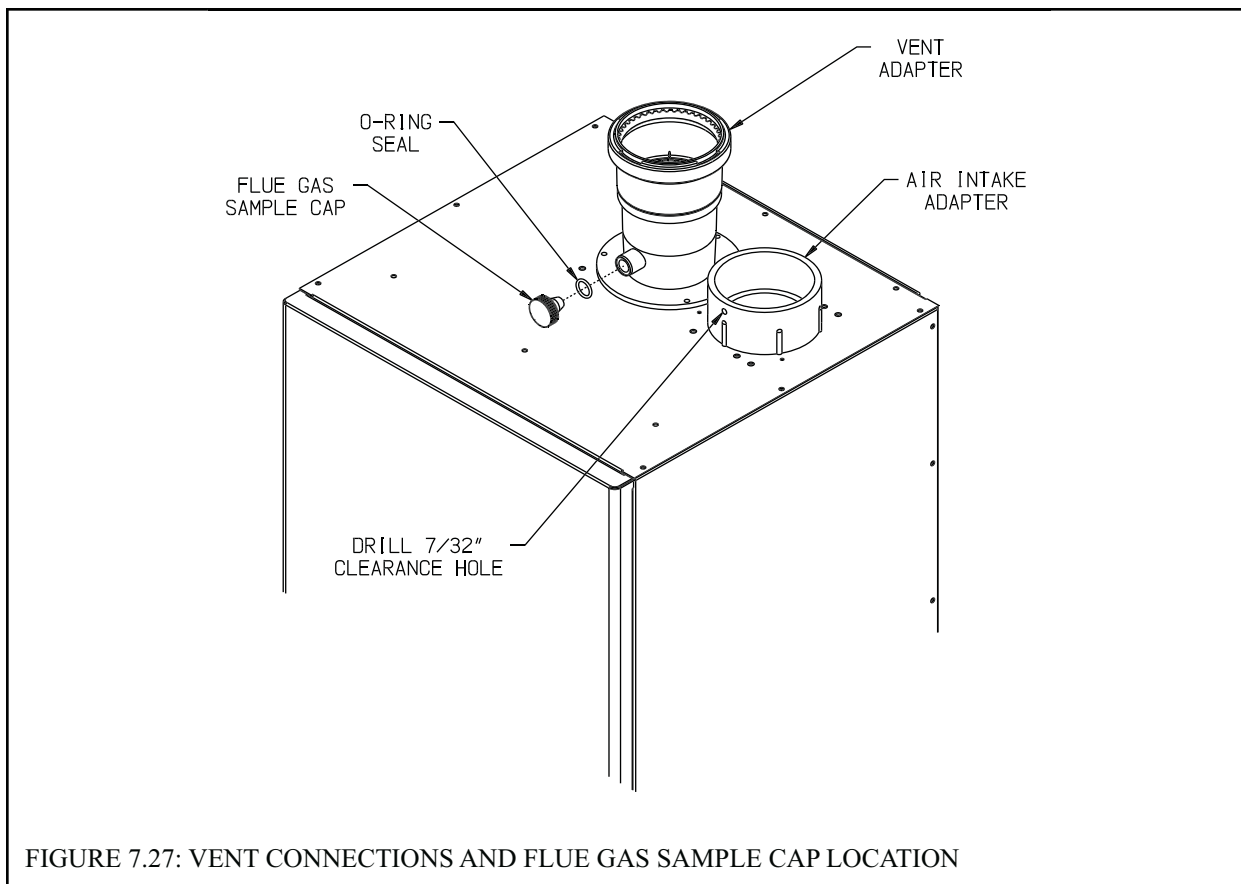

FIGURE 7.27: VENT CONNECTIONS AND FLUE GAS SAMPLE CAP LOCATION

- g. Assemble the rest of the vent system, being sure to pitch horizontal sections back towards the boiler 1/4"/ft. Support the vent at intervals not exceeding 4ft.
  - h. Maintain the clearances from the vent pipe outlined in Part VII-A of this manual. If exiting the exterior wall using PVC pipe, use half of an appropriately sized wall thimble (or a sheet metal plate) on the exterior of the building, to provide a weather tight seal while maintaining the proper clearance in the wall penetration. Seal the joint between the pipe and the wall plate using RTV applied on the exterior side of the wall. This sealant must not restrain the expansion of the vent pipe.
3. Installation of Air Intake System - Start assembly of the PVC air intake system at the boiler. Assembly of the air intake system is done in the same manner as the vent system except as follows:
- a. Drill a 7/32" clearance hole into the front side of the air intake adapter. Insert the first piece of PVC air intake pipe into the air intake connection and drill a 1/8" tap hole into the PVC which lines up with the 7/32" clearance hole and secure them together with a #10 x 1" sheet metal screw. Seal the joint between the intake pipe and the adaptor with RTV.
  - b. All intake piping may be PVC.
  - c. There is a 0" minimum clearance between the air intake piping and all types of construction.
  - d. To the extent possible, pitch horizontal air intake piping towards the outdoors.
4. Installation of Horizontal Fitting Terminals (Terminal Option A):
- a. See Figure 7.28 for proper orientation of twin pipe horizontal terminals. Outer edge of both terminals must be within 10" from wall surface. (Figure 7.6)
  - b. If desired, the terminals can be attached to the end of the vent and/or intake pipes with field supplied stainless steel screws so that they can be later removed for cleaning and inspection. If this is done, drill a clearance hole in the coupling or elbow and a tap hole in the end of the vent/intake pipes to accept these screws.
  - c. If these terminals are installed on snorkels, assemble the snorkels as shown in Figure 7.12. Brace the vertical run of piping on the building exterior as required.

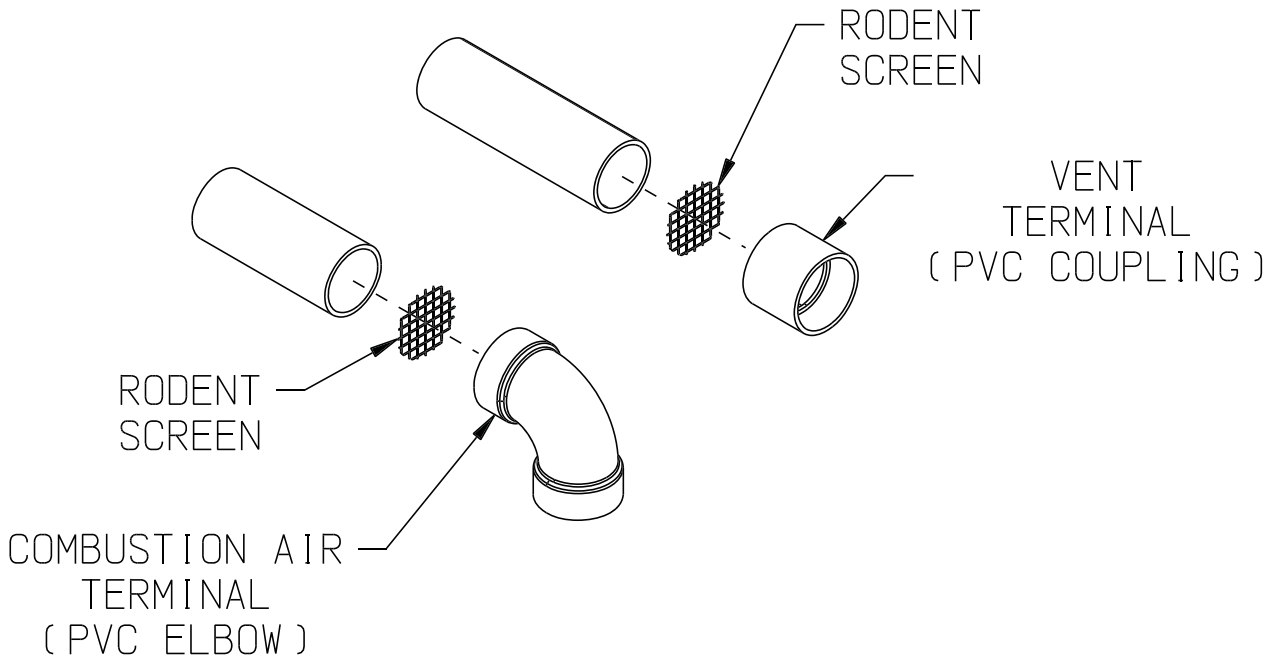

FIGURE 7.28: INSTALLATION OF STANDARD HORIZONTAL TERMINALS

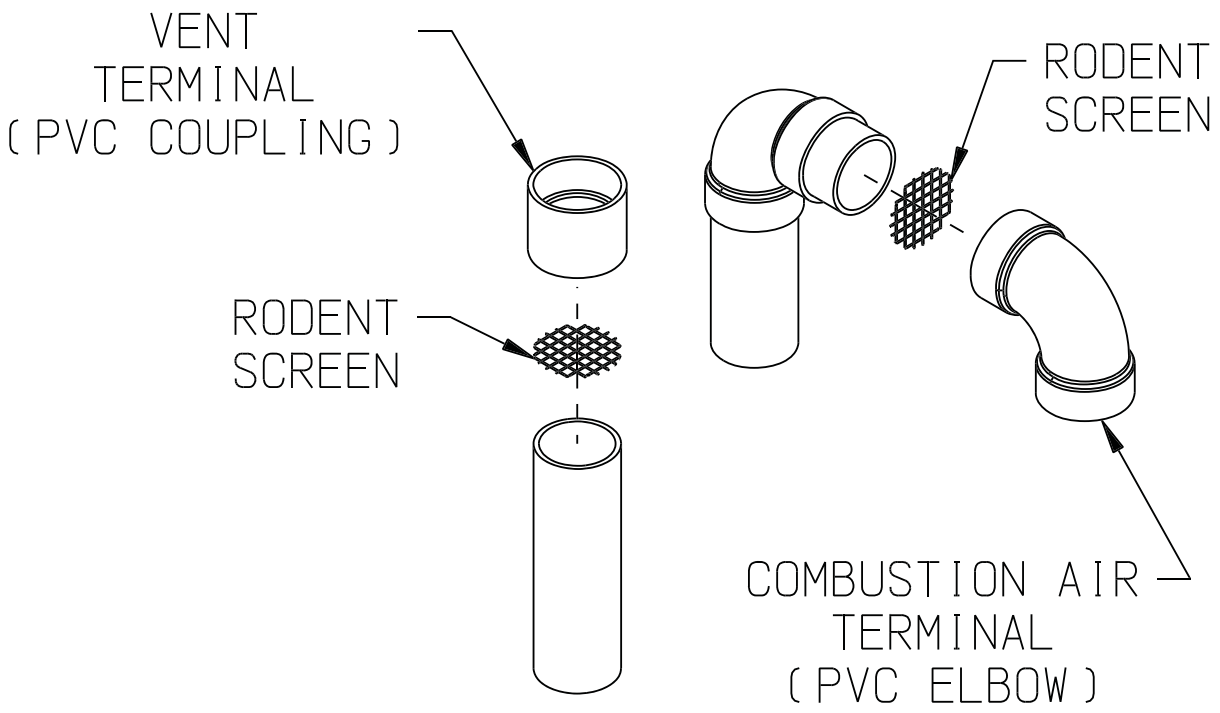

FIGURE 7.29: INSTALLATION OF STANDARD VERTICAL TERMINALS

5. Installation of Vertical Fitting Terminals (Terminal Option H):
  - a. See Figure 7.29 for the proper orientation of twin pipe vertical terminals.
  - b. The coupling is used to secure the rodent screen to the end of the vent pipe.
  - c. A 180° bend (or two 90° elbows) are installed on the top of the air intake pipe. If two 90° elbows are used, the rodent screen provided can be installed between them (Figure 7.29). If a 180° bend is used, install the rodent screen in the open side of the bend, using a ring made of PVC pipe. If desired, the termination fittings can be attached to the end of the vent and/or intake pipes with field supplied stainless steel screws so that they can be later removed for cleaning and inspection. If this is done, drill a clearance hole in these fittings and a tap hole in the end of the vent/intake pipes to accept these screws.
  - d. Use roof flashings and storm collars to prevent moisture from entering the building. Seal the roof flashing to the roof using generally accepted practice for the type of roof on the installation. Apply RTV to seal the storm collars to the vent and intake pipes.
6. Installation of IPEX low profile vent terminal (Terminal Option B) - See Figure 7.30:
  - a. Cut two holes in wall to accommodate the size PVC pipe being used. The distance between hole centers is 5.6”.
  - b. Slide both vent and intake air pipes through the holes. and cement them to the base of the vent termination kit using a primer and cement listed for use with PVC.
  - c. Fasten the vent base to the wall using the supplied screws and anchors. The anchors require the drilling of a 3/16” hole x 1-3/16” deep. Locate the holes using the vent base as a template.
  - d. Screw the vent cap to the vent base using the supplied screws.
  - e. Once the vent termination and pipes are secure seal the wall penetrations from the interior using a weather resistant RTV sealant.
7. Installation of Diversitech Low Profile Terminal (Terminal Option C) – See Figure 7.31:
  - a. Use vent plate as a guide to locate the openings for the vent and air intake pipes, as well as to locate the holes for the mounting screws.
  - b. Drill two 3-1/8 holes through the wall for the vent and intake pipes.
  - c. Drill four 3/16 holes for the mounting screws.
  - d. Install the vent and intake pipe sections passing through the wall. Cut the pipes so that they protrude the following distances from the surface on which the vent plate will be mounted:
    - Vent: Between 1-3/4 and 2-1/4”
    - Intake: Between ¼ and 1”
  - e. Seal pipe penetrations in wall with RTV (silicone sealant).
  - f. Mount the vent plate using the #8 x 2” screws and anchors provided with this kit.
  - g. Seal the vent plate to the wall with RTV.
  - h. Apply a bead of RTV around the OD of the vent pipe near its end.
  - i. Slide the vent cap over the vent pipe and secure to the wall plate with the #8 x 2” screws provided.
8. Installation of IPEX FGV or Diversitech CVENT Concentric Vent Terminal (Terminal Options D,E,I & J) - This terminal may be used for either horizontal or vertical venting. See Figure 7.33 for horizontal installation or Figure 7.34 for vertical installation. When PVC is used for venting the 30” CPVC straight section and CPVC elbow supplied must be used prior to connection of the vent system to this terminal. If the vent system is too short to permit this, use the IPEX FGV CPVC terminal:
  - a. For horizontal installations at the planned location cut a round hole in the exterior wall 1/2” larger than the “C” dimension indicated on Figure 7.32 for the size terminal being used. (See Part VII-B of this manual for permitted terminal locations).
  - b. For vertical installations, cut a hole in the roof large enough to clear the concentric terminal at the location of the terminal (see Part VII-C of this manual for permitted terminal locations).
  - c. If desired, the terminal can be shortened. See Figure 7.32 for specific information on making the terminal kit shorter based on the kit size being used. Cut the pipe squarely and de-burr both the OD and ID of the cut edges.
  - d. Cement the inner pipe section of PVC pipe supplied with this kit to the Wye fitting using a primer and cement listed for use with PVC.



## WARNING

- **Asphyxiation Hazard. CPVC/PVC vent piping and fittings rely on glued joints for proper sealing. Follow all manufacturer instructions and warnings when preparing pipe ends for joining and using the primer and the cement.**
- **When PVC is used with the concentric vent kit, the 30” CPVC straight section and elbow must be used prior to connection of the vent system to this terminal. If the vent system is too short to permit this, use an IPEX FGV CPVC terminal.**
- **Do not operate boiler without the rain cap in place.**
- **Method of securing and sealing terminals to the outside wall must not restrain the expansion of vent pipe.**



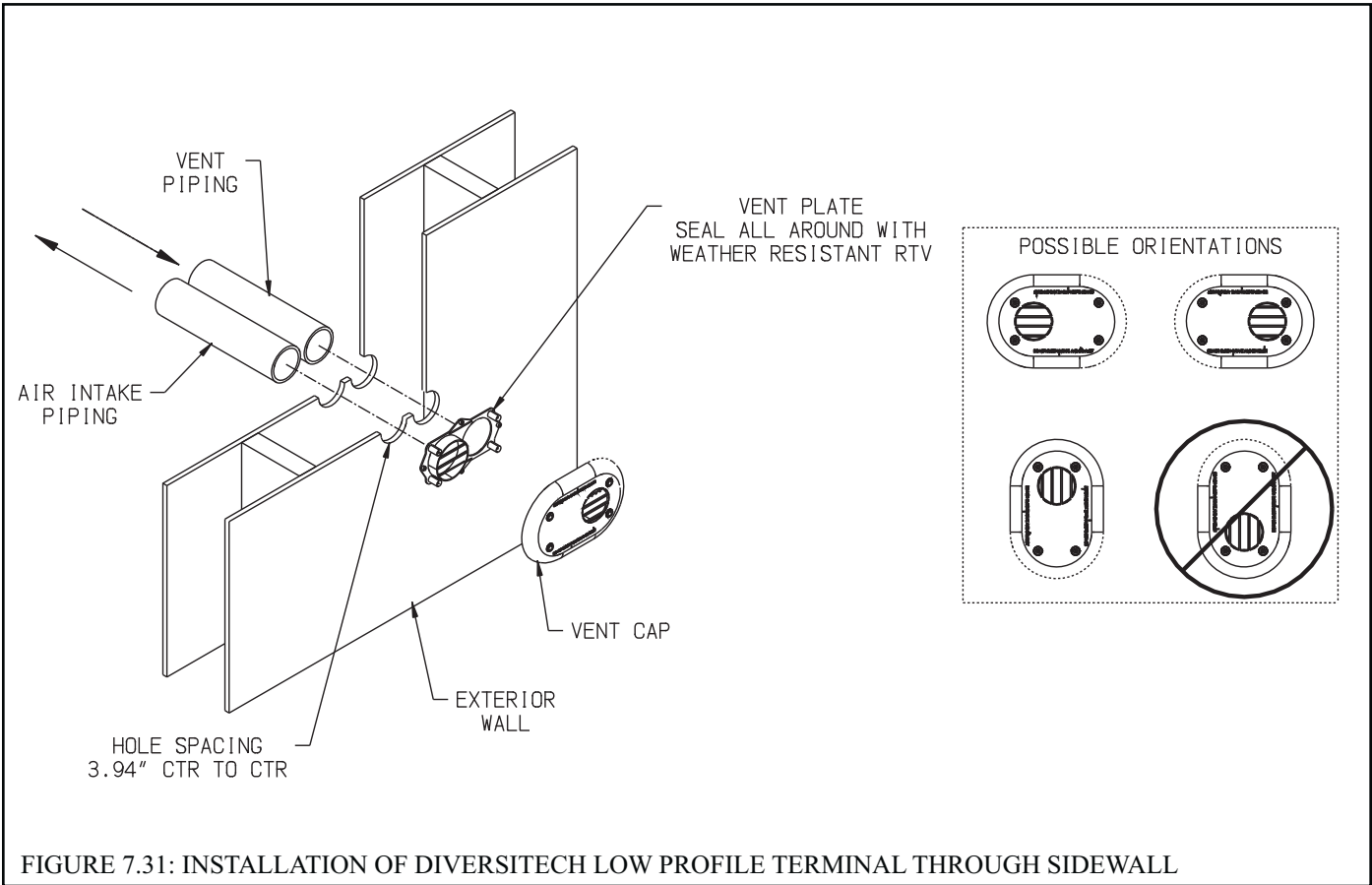
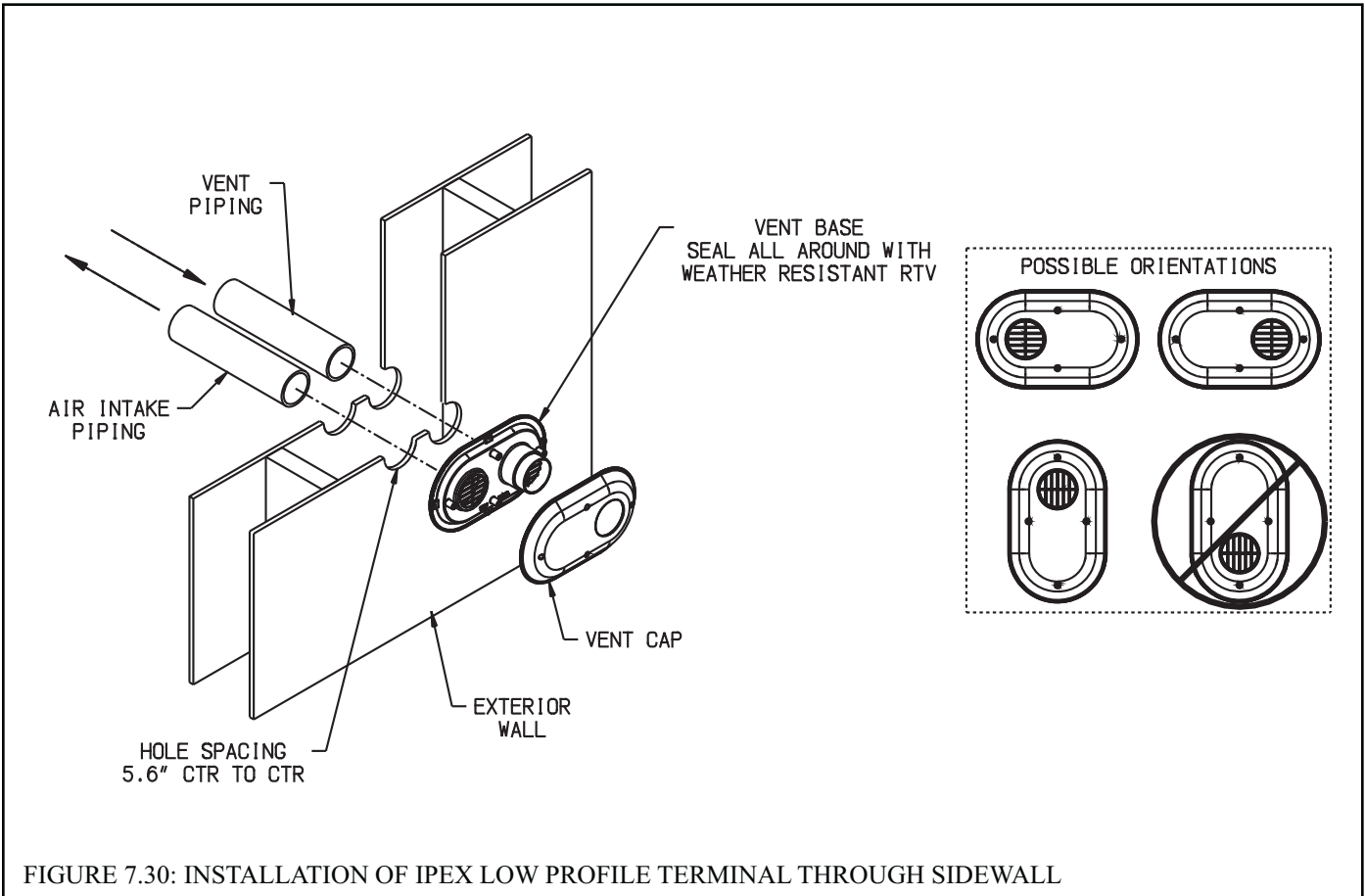

\*OVERALL LENGTH OF INNER PIPE TO BE 'A' INCHES LONGER THAN OVERALL LENGTH OF OUTER PIPE.

KIT SIZE	*' A'	' B'	' C'	MANUFACTURER
2"	7-3/8"	1-3/4"	3-1/2"	IPEX
2"	12-3/16"	3/4"	3-1/2"	DIVERSITECH
3"	8-3/4"	2-1/4"	4-1/2"	IPEX
3"	13-3/16"	1"	4-1/2"	DIVERSITECH

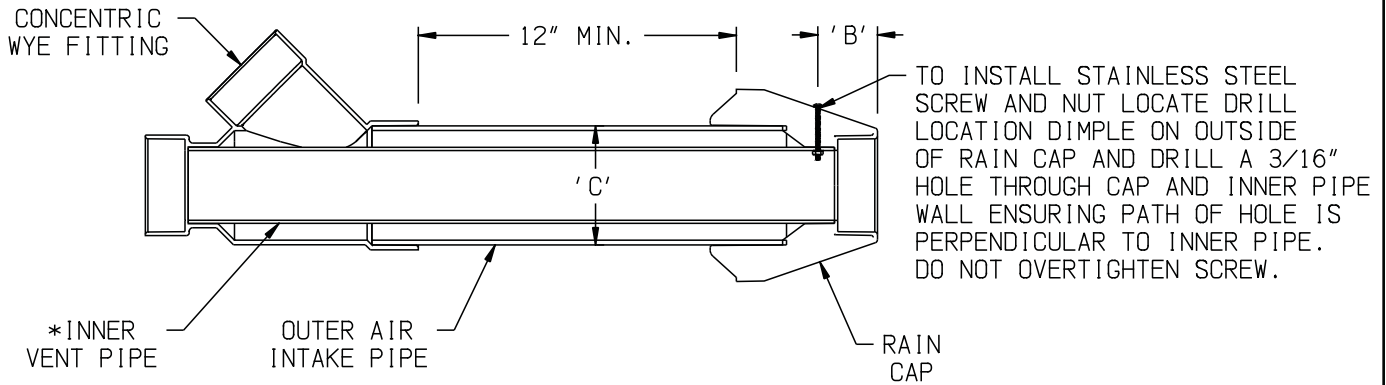

- NOTES: 1. ALL CUTS MUST BE SQUARE AND DEBURRED.  
 2. LENGTHENING OF TERMINAL IS NOT PERMITTED.

FIGURE 7.32: CUTTING IPEX AND DIVERSITECH CONCENTRIC VENT TERMINALS

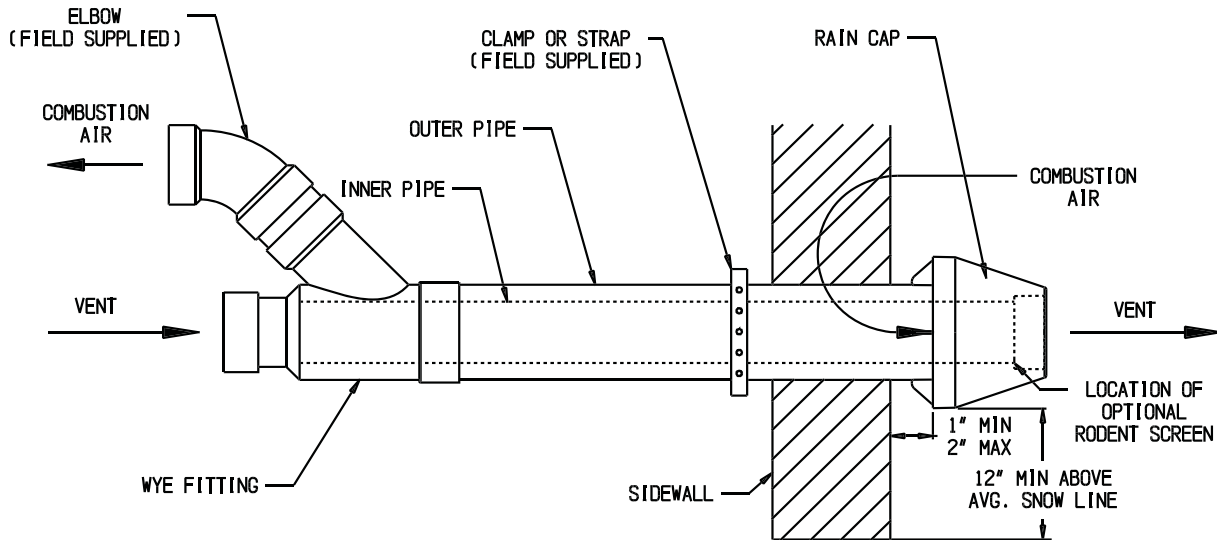

FIGURE 7.33: INSTALLATION OF IPEX AND DIVERSITECH CONCENTRIC TERMINAL THROUGH SIDEWALL

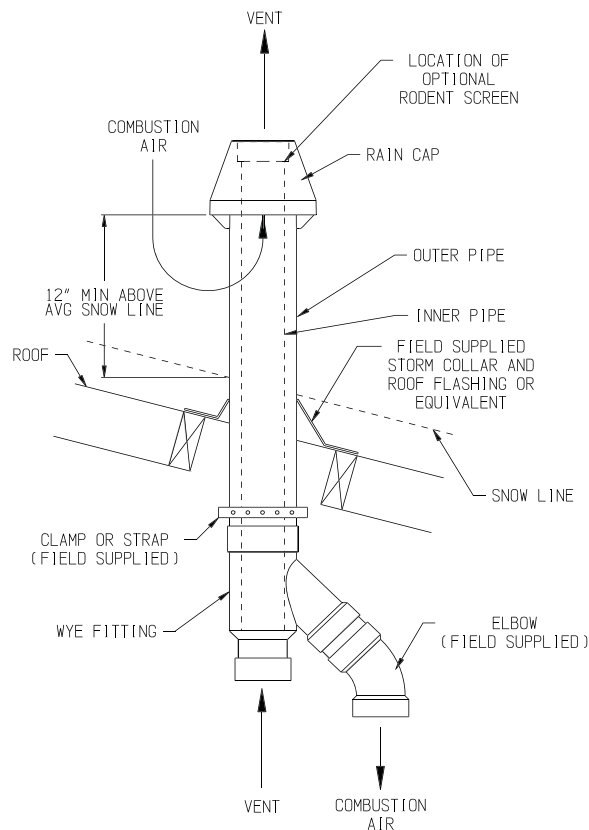

FIGURE 7.34: INSTALLATION OF IPEX AND DIVERSITECH CONCENTRIC TERMINAL THROUGH ROOF

- e. Cement the outer pipe to the Wye, being careful, to keep the inner and outer pipes concentric.
- f. Slip the partially assembled terminal through the wall or ceiling from the inside and for horizontal installations orient so that the side outlet on the Wye is on or above the horizontal plane.
- g. For horizontal installations, seal the gap between the OD of the “outer pipe” and the exterior side of the wall with RTV sealant.
- h. Cement the rain cap onto the inner pipe. If desired, the rain cap can be attached to the inner pipe with the supplied stainless steel screw and nut so that it can be later removed for cleaning and inspection. If this is done, drill a 3/16” clearance hole in the rain cap and inner pipe in the location shown on Figure 7.32 for the size terminal kit being used and affix screw and nut. Do not overtighten. A field supplied rodent screen may also be installed on the end of the rain cap.
- i. For vertical installations, use a roof flashing and storm collar to prevent moisture from entering the building. Seal the roof flashing to the roof using generally accepted practice for the type of roof on the installation. Install the storm collar after verifying that the bottom of the rain cap will be at least 12” above the normal snow line. Apply RTV to seal the storm collars to the terminal.

## F. Assembly of DuraVent PolyPro Vent Systems

1. This boiler has been approved for use with the DuraVent PolyPro single wall polypropylene vent system to be provided by the installer.

### WARNING

- **Asphyxiation Hazard.** Follow these instructions and the installation instructions included by the original polypropylene venting component manufacturer, M&G/DuraVent. Failure to do so could cause products of combustion to enter the building, resulting in severe property damage, personal injury or death. Where a conflict arises between M&G/DuraVent instructions and these instructions, the more restrictive instructions shall govern.
- **Do not mix vent components or joining methods for listed manufacturers.**
- **Examine all components for possible shipping damage prior to installation.**
- **All condensate that forms in the vent must be able to drain back to the boiler.**

2. Assemble the vent system, starting at the boiler:

- a. The vent adaptor has two different inside diameters. The smaller, lower, inside diameter accepts 3" nominal PolyPro (Figure 7.27). A locking ring in the adaptor prevents the vent pipe from coming out of the adaptor once it is inserted. Lubricate the upper gasket in the vent adaptor with soapy water and insert the first piece of 3" PolyPro into the adaptor until it bottoms out.

### NOTICE

Once a vent pipe is inserted into this adaptor, it is **IMPOSSIBLE** to remove it. Make sure the correct type of pipe is selected, and that it is of the correct length, before inserting it into the vent adaptor.

- b. If 2" Polypro is to be used for the vent system, reduce the first piece of 3" Polypro installed in Step (a) to 2" using DuraVent # 3PPS-R2. Otherwise assemble the next piece of 3" Polypro.
- c. For each joint, verify that the gasket is evenly seated in the bell (female) end of the pipe. Lubricate this gasket with water. Slide a locking band over the male end of the pipe to be joined as shown in Figure 7.35. Push the male end of the next section of pipe into the bell until it bottoms out, then back out 1/4-5/8" to provide room for thermal expansion. Push barb on locking band over the bell end of the first section of pipe as shown in Figure 7.35.
- d. Assemble the rest of the vent system per the manufacturer's installation instructions, being sure to pitch horizontal sections back towards the boiler 5/8" per ft.
- e. Support each horizontal pipe section with a minimum of one wall strap each and at intervals not exceeding 4ft.

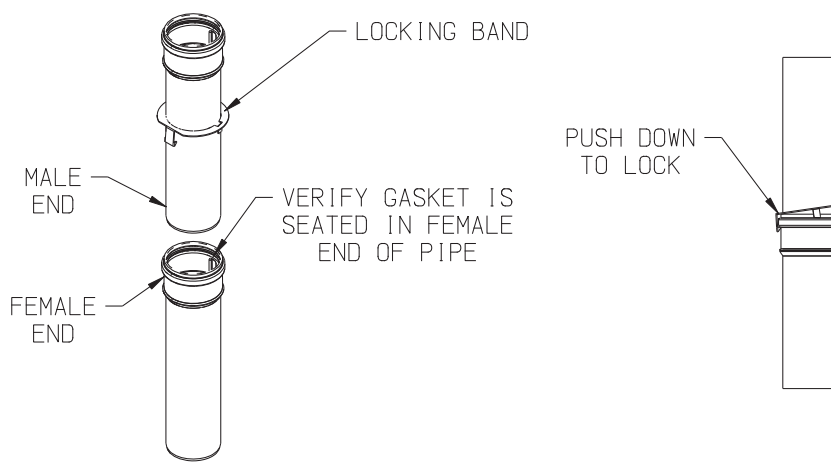

FIGURE 7.35: POLYPRO LOCKING BAND INSTALLATION

3. Installation of Air Intake System - Start assembly of the PVC air intake system at the boiler. Assembly of the air intake system is done in the same manner as the vent system except as follows:
  - a. Drill a 7/32" clearance hole into the front side of the air intake adapter. Insert the first piece of PVC air intake pipe into the air intake connection and drill a 1/8" tap hole into the PVC which lines up with the 7/32" clearance hole and secure them together with a #10 x 1" sheet metal screw. Seal the joint between the intake pipe and the adaptor with RTV.
  - b. All intake piping may be PVC.
  - c. There is a 0" minimum clearance between the air intake piping and all types of construction.
  - d. To the extent possible, pitch horizontal air intake piping towards the outside.



## WARNING

**Asphyxiation Hazard. Vent systems made by M&G/DuraVent rely on gaskets for proper sealing. When this vent system is used, take the following precautions:**

- **Make sure that gasket is in position and undamaged in the female end of the pipe.**
- **Make sure that both the male and female pipes are free of damage prior to assembly.**
- **Only cut vent pipe as permitted by the vent manufacturer in accordance with their instructions. When pipe is cut, the cut end must be square and carefully de-burred prior to assembly.**
- **Use locking bands at all vent pipe joints.**
- **Do not use anything other than soapy water to lubricate gaskets.**

## NOTICE

**The venting system must be free to expand and contract and supported in accordance with the installation instructions included by the original polypropylene venting component manufacturer, M&G/DuraVent. Polypropylene pipe sections must be disengaged 1/4 to 5/8 in. (6mm to 16mm) per joint to allow for thermal expansion.**

4. Installation of Horizontal Fitting Terminals (Terminal Option A):
  - a. See Figure 7.36 for proper orientation of twin pipe horizontal terminals. Outer edge of exhaust coupling must be 10" or less from the wall surface. (Figure 7.9)
  - b. Remove the gasket from the end of the integral exhaust coupling and insert DuraVent Bird Guard #2PPS-BG or #3PPS-BG in it's place.
  - c. Add PVC intake per instructions from Part VII-F.
5. Installation of Vertical Fitting Terminals (Terminal Option H):
  - a. See Figure 7.37 for the proper orientation of twin pipe vertical terminals.
  - b. Remove the gasket from the end of the integral exhaust coupling and insert the installer supplied rodent screen in it's place.
  - c. A 180° bend (or two 90° elbows) are installed on the top of the air intake pipe. If two 90° elbows are used, the rodent screen provided can be installed between them (Figure 7.37). If a 180° bend is used, install the rodent screen in the open side of the bend, using a ring made of PVC pipe. If desired, the termination fittings can be attached to the end of the intake pipes with field supplied stainless steel screws so that they can be later removed for cleaning and inspection. If this is done, drill a clearance hole in these fittings and a tap hole in the end of the intake pipes to accept these screws.
  - d. Use roof flashings and storm collars to prevent moisture from entering the building. Seal the roof flashing to the roof using generally accepted practice for the type of roof on the installation. Apply RTV to seal the storm collars to the vent and intake pipes.

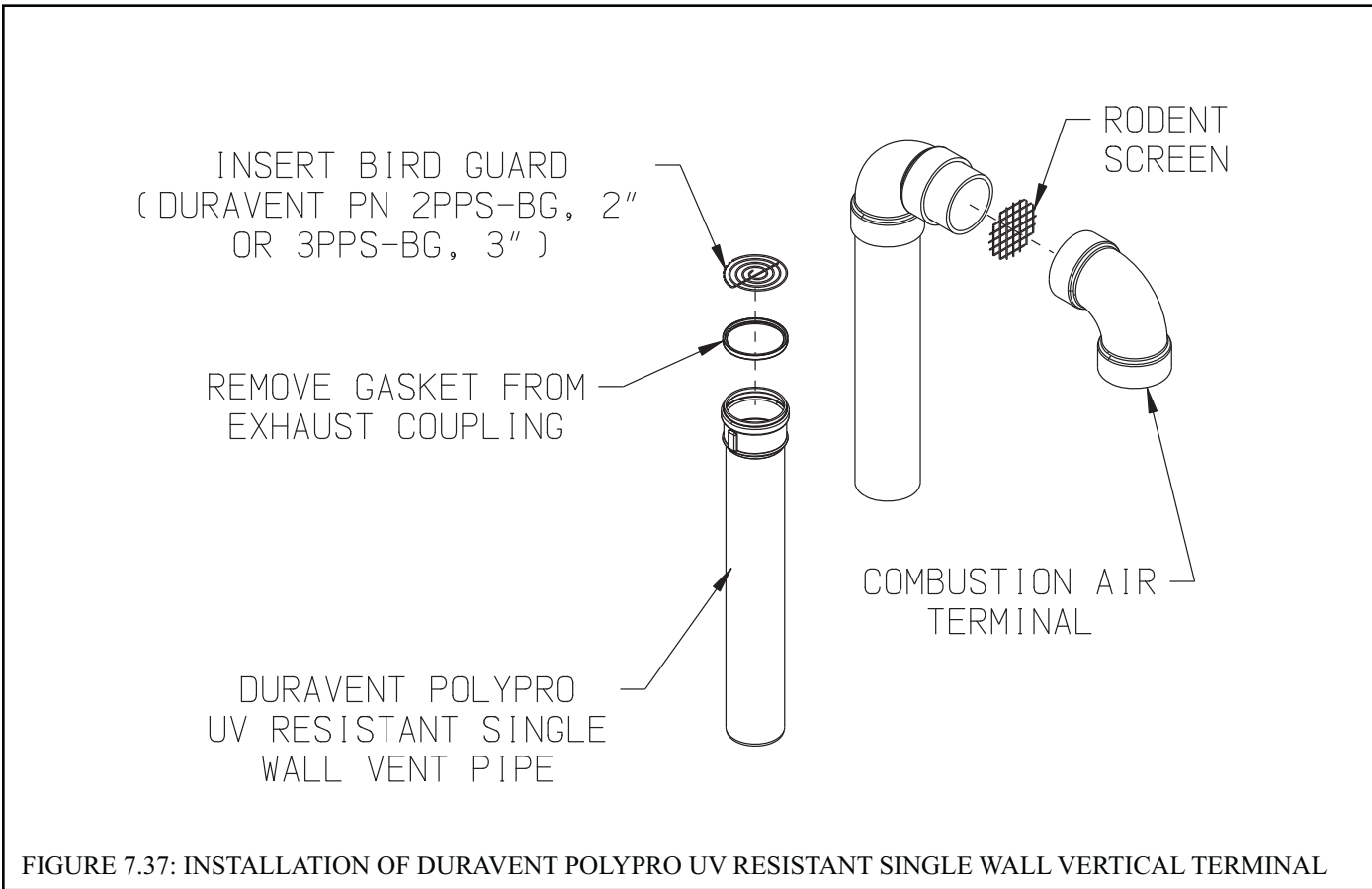
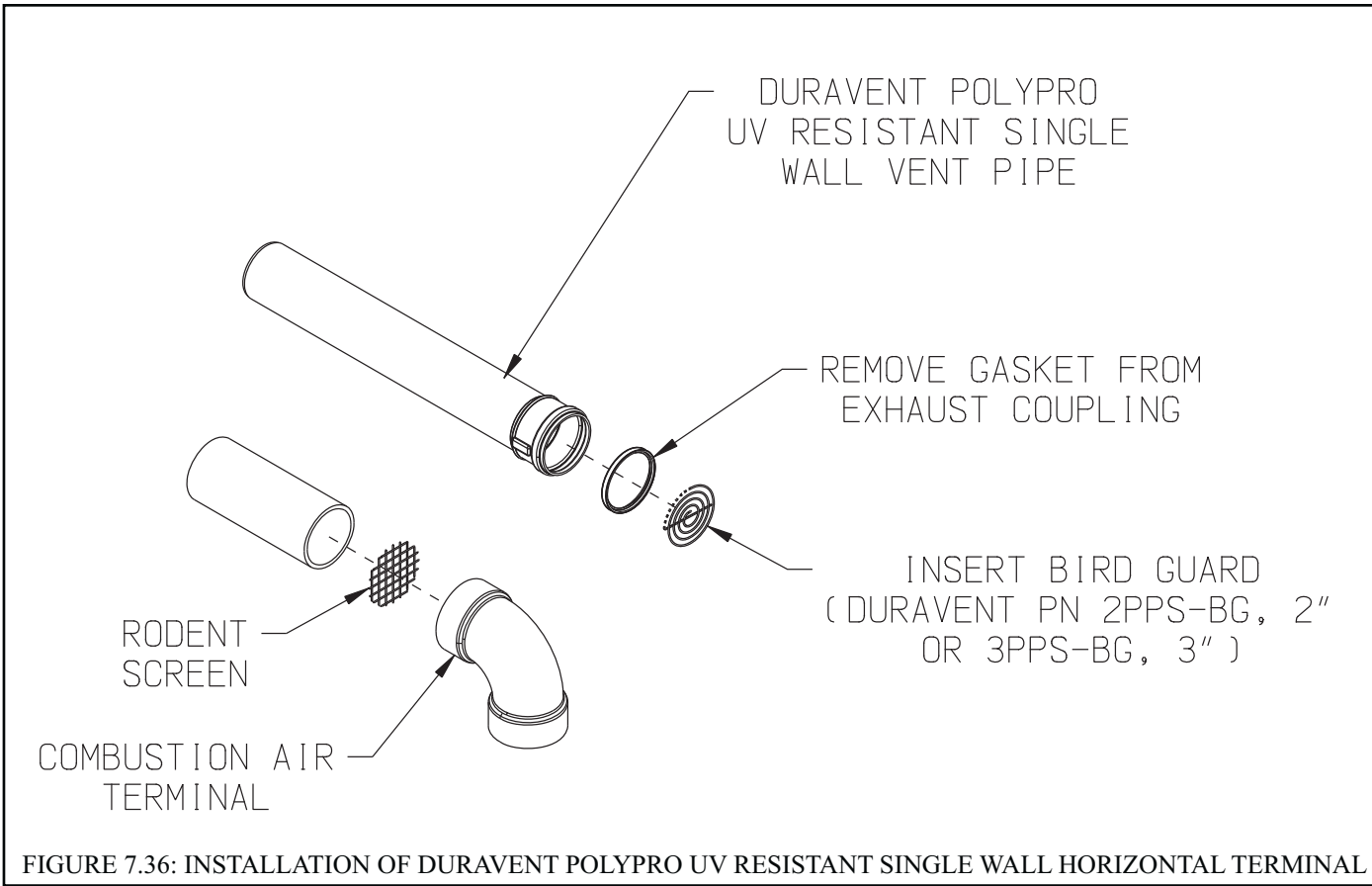

6. Installation of DuraVent PolyPro Horizontal Concentric Vent Terminal (Terminal Option D) -

Install PolyPro Horizontal Concentric Termination Kit #2PPS-HK or #3PPS-HK (Figure 7.39) as follows:

- a. At the planned location cut a 4-1/8" round hole for the 2" terminal or a 5-1/8" round hole for the 3" terminal in the exterior wall. (See Part VII-A of this manual for permitted terminal locations).
- b. If desired, the terminal can be shortened. Mark the desired location of the cut on the outer pipe no closer than 2" from the edge of the tab on the interior wall plate. Prior to cutting outer pipe measure dimension 'A' of the inner pipe as shown in Figure 7.38 and maintain this dimension after cutting the outer pipe. All cuts must be square and de-burred.
- c. Attach the exterior wall plate and seal all around with weather resistant RTV.
- d. Slide the cap through the exterior wall plate and hole from the outside of the building and orient the termination so the air intake slots face down. The cap must be installed level or sloped 1/8" per foot away from the appliance.
- e. Seal the termination to the exterior wall plate with weather resistant RTV.
- f. Slide the interior wall plate over the termination and attach to the wall from inside the room.
- g. Attach the interior wall plate to the termination with the provided hardware.
- h. Install gaskets into co-linear adapter.
- i. Attach co-linear adapter to horizontal termination and orient so that the side outlet on the adapter is on or above the horizontal plane.

7. Vertical Installations using PolyPro Vertical Concentric Termination Kit #2PPS-VK or #3PPS-VK (Figure 7.40):

- a. Cut a hole in the roof large enough to clear the concentric terminal at the location of the terminal (see Part VII-A of this manual for permitted terminal locations).
- b. Use a roof flashing and storm collar to prevent moisture from entering the building. See Figure 7.40 for the model number of the flashing to be used depending on the type of roof. Seal the roof flashing to the roof using generally accepted practice for the type of roof on the installation.
- c. Slide the vertical termination into the flashing from above until seated on the flashing.
- d. Plumb the termination and mount the support bracket to the structure.
- e. Install gaskets into co-linear adapter.
- f. Attach co-linear adapter to vertical termination.

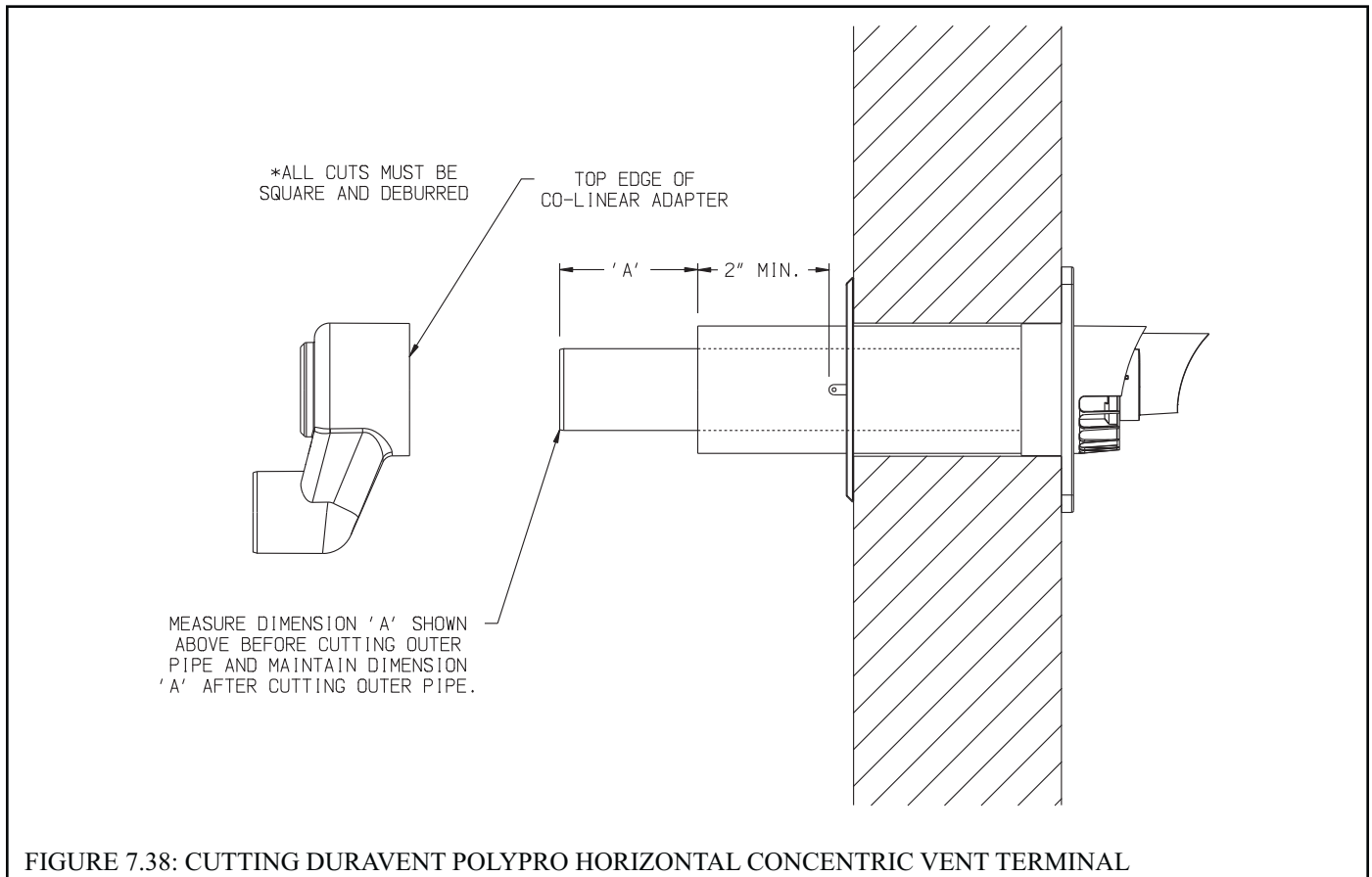

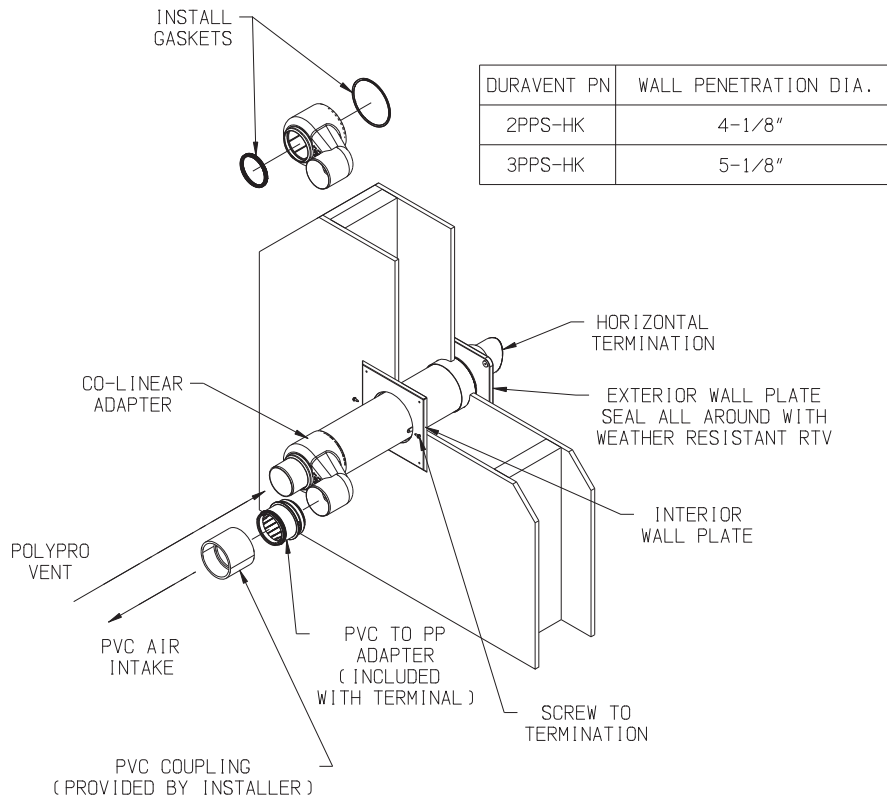

FIGURE 7.39: INSTALLATION OF DURAVENT POLYPRO CONCENTRIC VENT TERMINAL THROUGH SIDEWALL

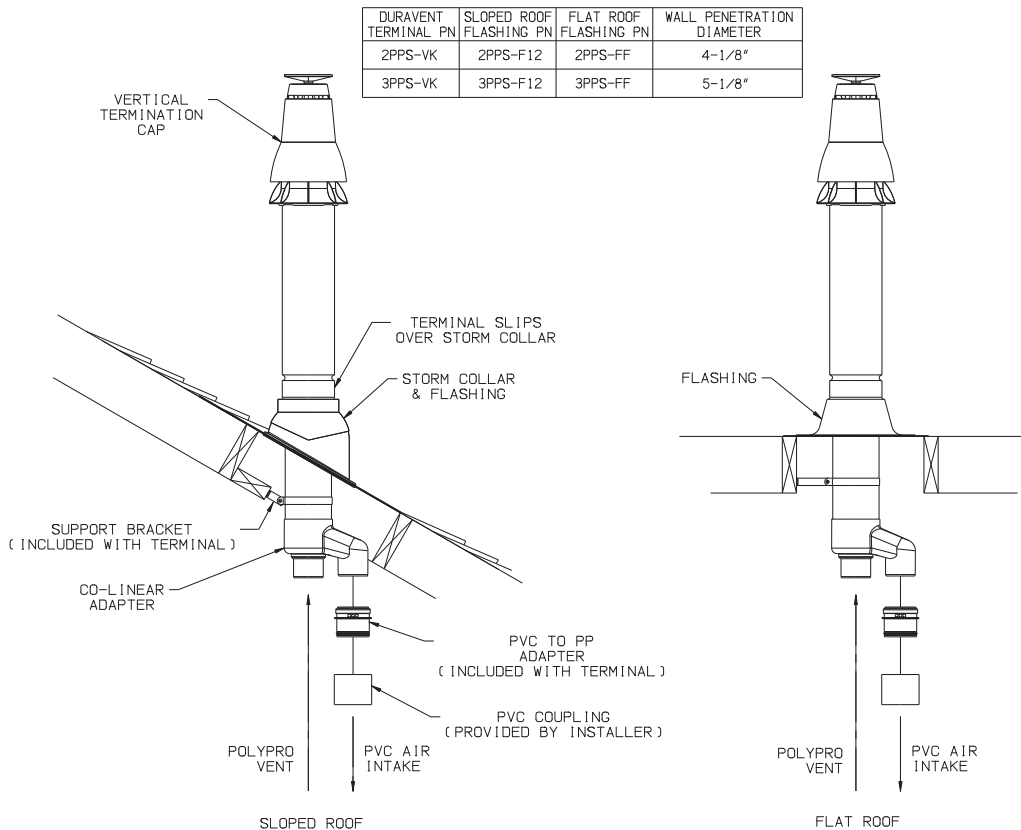

FIGURE 7.40: INSTALLATION OF DURAVENT POLYPRO CONCENTRIC TERMINAL THROUGH ROOF



8. Installations using PolyPro-flex (Vent Options 18,19,33,34):



## WARNING

**Asphyxiation Hazard. When using Polypro flex, observe the following precautions:**

- **Polypro flex may be damaged by handling at low temperatures. Do not bend, uncoil, or attempt to install if it has been stored at a temperature below 42F without allowing it to warm to a higher temperature first.**
- **Do not bend PolyPro flex more than 45 degrees.**
- **Instructions below reference the DuraVent PolyPro Flex instruction manual. Not all vent configurations shown in the DuraVent manual are approved for use with this boiler.**

Refer to DuraVent Polypro flex Instructions for assembly of all flex components including the chimney cap and the adaptor to rigid Polypro at the base of the masonry or B vent chimney. In addition, observe the following requirements:

- a. Refer to the appropriate Vent option in Tables 7.13b or 7.21 for a list of the principle flex components required. Rigid vent pipe by the same manufacturer will also be required for the run from the boiler to the base of chimney.
- b. Masonry chimneys cannot be used for an air chase
- c. B vent chimneys can only be used for an air chase (Vent options 18, 19) if the B vent has the minimum size shown in Table 7.13b and is fully accessible for sealing of all joints and seams.
- d. When Vent Option 18 or 19 is used, install a Tee on the base of the B-vent that is the same size as the B- Vent chimney. Install the PolyPro Lower B-Vent adaptor in the base of this Tee as described in the DuraVent PolyPro Flex instructions. Connection of the PVC air intake pipe to the side outlet of the tee is made using a cap and a PVC socket x male thread adaptor (2" or 3", depending on the Vent Option). Cut a clearance hole in the cap for the male threads. Secure the adaptor to the cap using a 2" or 3" electrical conduit lock nut. Seal all joints with RTV.

### G. Assembly of Selkirk Polyflue Vent Systems

1. This boiler has been approved for use with the Selkirk Polyflue single wall polypropylene vent system to be provided by the installer.



## WARNING

**Asphyxiation Hazard. Follow these instructions and the installation instructions included by the original polypropylene venting component manufacturer, Selkirk. Failure to do so could cause products of combustion to enter the building, resulting in severe property damage, personal injury or death. Where a conflict arises between Selkirk instructions and these instructions, the more restrictive instructions shall govern.**

- **Do not mix vent components or joining methods for listed manufacturers.**
- **Examine all components for possible shipping damage prior to installation.**
- **All condensate that forms in the vent must be able to drain back to the boiler.**

2. Assemble the vent system, starting at the boiler:
  - a. The vent adaptor has two different inside diameters. The smaller, lower, inside diameter accepts 3" nominal Polyflue (Figure 7.27). A locking ring in the adaptor prevents the vent pipe from coming out of the adaptor once it is inserted. Lubricate the upper gasket in the vent adaptor with mild soapy water and insert the first piece of 3" Polyflue into the adaptor until it bottoms out.
  - b. If 2" Polyflue is to be used for the vent system, reduce the first piece of 3" Polyflue installed in Step (a) to 2" using Selkirk #3PF-3R2. Otherwise assemble the next piece of 3" Polyflue.
  - c. For each joint, verify that the gasket is evenly seated in the bell (female) end of the pipe. Lubricate this gasket with mild soapy water. Slide a Pipe Locking Band over the male end of the pipe to be joined as shown in Figure 7.41. Push the male end of the next section of pipe into the bell until it bottoms out, then back out 1/8—1/4" to provide room for thermal expansion. Slide pipe locking band over the female end of the connections and tighten both hose clamps.
  - d. Assemble the rest of the vent system per the manufacturer's installation instructions, being sure to pitch horizontal sections back towards the boiler 5/8" per ft.

- e. Support each pipe section as described in Polyflue manual at intervals not exceeding the following:

Pipe size	Horizontal	Vertical
2"	30in	16ft
3"	39in	16ft

## NOTICE

**Once a vent pipe is inserted into this adaptor, it is IMPOSSIBLE to remove it. Make sure the correct type of pipe is selected, and that it is of the correct length, before inserting it into the vent adaptor.**

3. Installation of Air Intake System - Start assembly of the PVC air intake system at the boiler. Assembly of the air intake system is done in the same manner as the vent system except as follows:
  - a. Drill a 7/32" clearance hole into the front side of the air intake adapter. Insert the first piece of PVC air intake pipe into the air intake connection and drill a 1/8" tap hole into the PVC which lines up with the 7/32" clearance hole and secure them together with a #10 x 1" sheet metal screw. Seal the joint between the intake pipe and the adaptor with RTV.
  - b. All intake piping may be PVC. There is a 0" minimum clearance between the air intake piping and all types of construction.
  - c. To the extent possible, pitch horizontal air intake piping towards the outside.
4. Installation of Horizontal Fitting Terminals (Terminal Option A):
  - a. See Figure 7.42 for proper orientation of twin pipe horizontal terminals. Outer edge of exhaust coupling must be 10" or less from the wall surface. (Figure 7.9)
  - b. Remove the gasket from the end of the integral exhaust coupling and insert Selkirk #2PF-HVST or #3PFHVST in its place.
  - c. Add PVC intake per instructions from Part VII-F.
5. Installation of Vertical Fitting Terminals (Terminal Option H):
  - a. See Figure 7.43 for the proper orientation of twin pipe vertical terminals.
  - b. Remove the gasket from the end of the integral exhaust coupling and insert Selkirk #2PF-HVST or #3PFHVST in its place.
  - c. A 180° bend (or two 90° elbows) are installed on the top of the air intake pipe. If two 90° elbows are used, the rodent screen provided can be installed between them (Figure 7.43). If a 180° bend is used, install the rodent screen in the open side of the bend, using a ring made of PVC pipe. If desired, the termination fittings can be attached to the end of the intake pipes with field supplied stainless steel screws so that they can be later removed for cleaning and inspection. If this is done, drill a clearance hole in these fittings and a tap hole in the end of the intake pipes to accept these screws.
  - d. Use roof flashings and storm collars to prevent moisture from entering the building. Seal the roof flashing to the roof using generally accepted practice for the type of roof on the installation. Apply RTV to seal the storm collars to the vent and intake pipes.



## WARNING

**Asphyxiation Hazard. Selkirk Polyflue vent systems rely on gaskets for proper sealing. When this vent system is used, take the following precautions:**

- **Make sure that gasket is in position and undamaged in the female end of the pipe.**
- **Make sure that both the male and female pipes are free of damage prior to assembly.**
- **Only cut vent pipe as permitted by the vent manufacturer in accordance with their instructions. When pipe is cut, the cut end must be square and carefully de-burred prior to assembly.**
- **Use pipe locking bands at all vent pipe joints.**

## NOTICE

**The venting system must be free to expand and contract and supported in accordance with the installation instructions included by the original polypropylene venting component manufacturer, Selkirk. Polypropylene pipe sections must be disengaged 1/8 to 1/4 in. (3mm to 6mm) per joint to allow for thermal expansion.**

6. Installations using flexible Polyflue (Vent Options 35,36):

**WARNING**

**Asphyxiation Hazard. When using Polyflue flex, observe the following precautions:**

- Polyflue flex may be damaged by handling at low temperatures. Do not bend, uncoil, or attempt to install if it has been stored at a temperature below 42F without allowing it to warm to a higher temperature first.
- Do not bend Polyflue flex more than 45 degrees.
- Instructions below reference the Selkirk Polyflue instruction manual. Not all vent configurations shown in the Selkirk vent manual are approved for use with this boiler.

Refer to Selkirk Polyflue Instructions for assembly of all flex components including the chimney cap and the adaptor to rigid Polyflue at the base of the masonry or B vent chimney. In addition, observe the following requirements:

- a. Refer to the appropriate Vent option in Table 7.21 for a list of the principle flex components required. Rigid vent pipe by the same manufacturer will also be required for the run from the boiler to the base of the chimney.
- b. Polyflue may not be used in air chase applications.

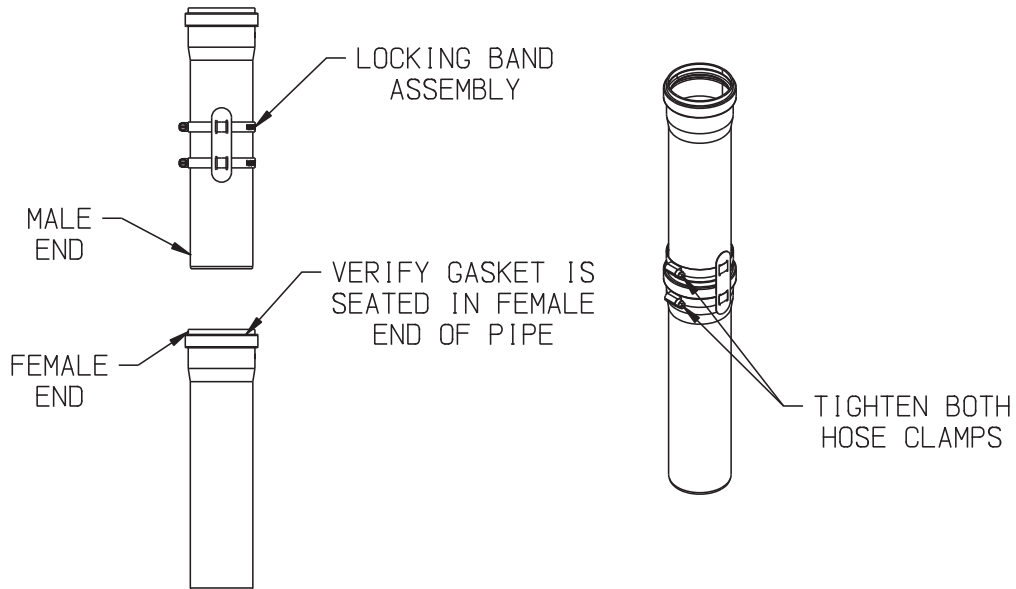

FIGURE 7.41: POLYFLUE PIPE LOCKING BAND INSTALLATION

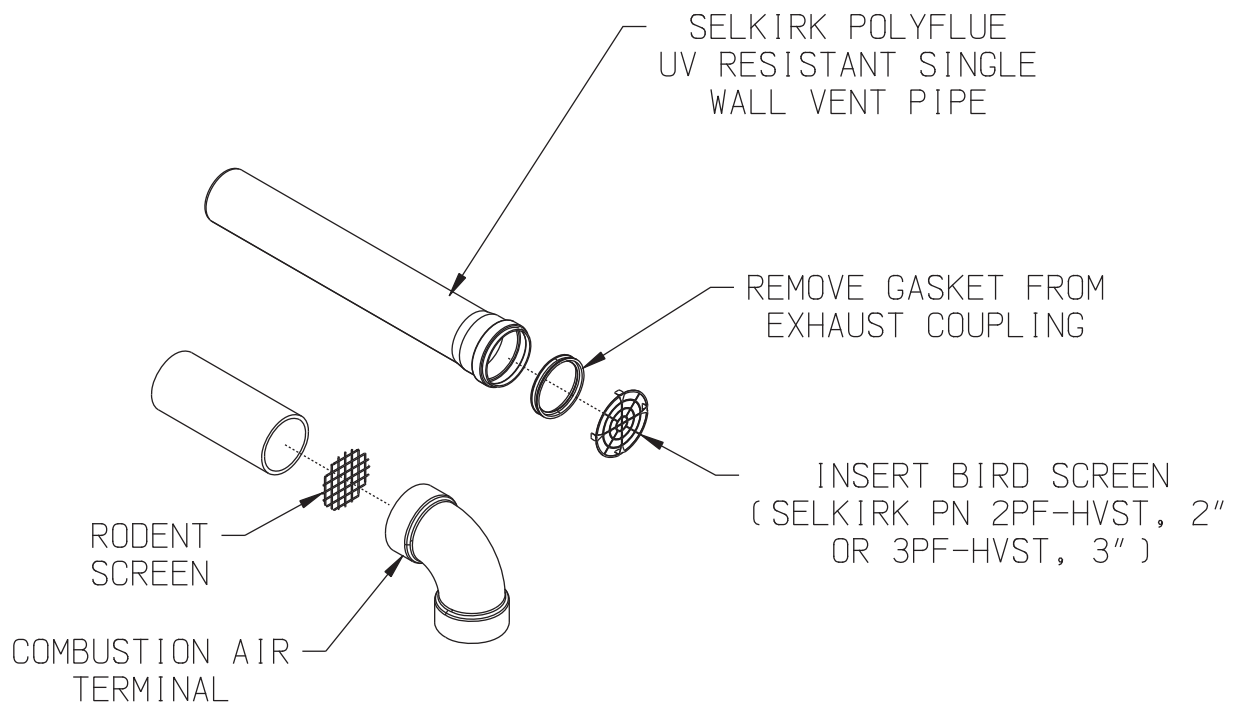

FIGURE 7.42: INSTALLATION OF SELKIRK POLYFLUE UV RESISTANT SINGLE WALL HORIZONTAL TERMINAL

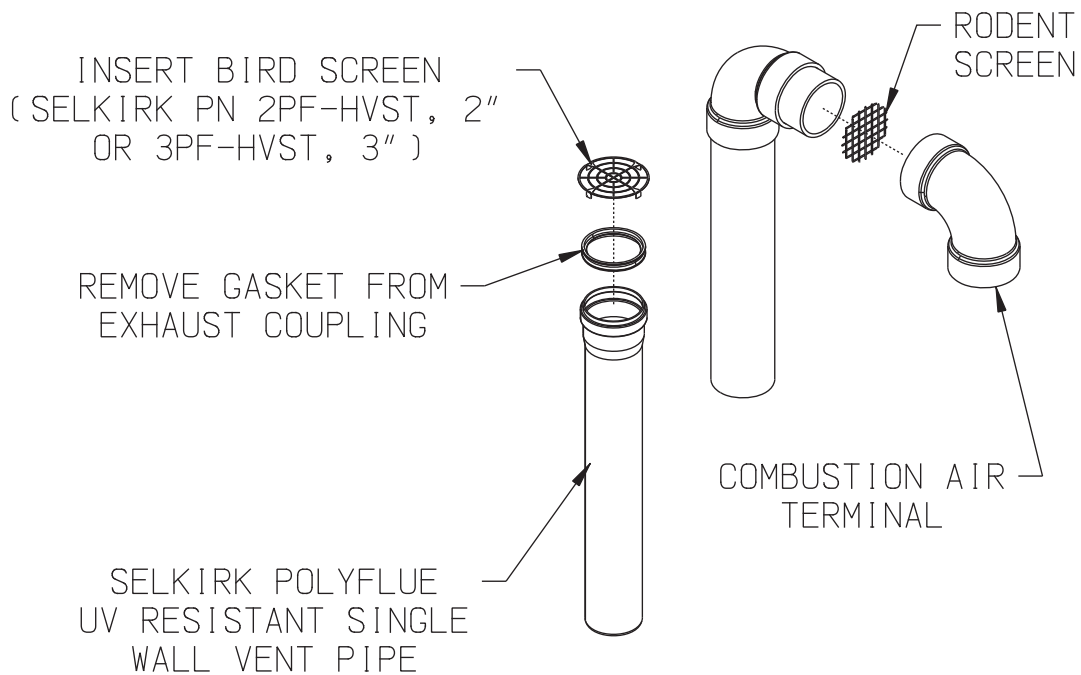

FIGURE 7.43: INSTALLATION OF SELKIRK POLYFLUE UV RESISTANT SINGLE WALL VERTICAL TERMINAL

## H. Assembly of Centrotherm Innoflue Vent Systems

1. This boiler has been approved for use with the Centrotherm Innoflue single wall polypropylene vent system to be provided by the installer.



### WARNING

- **Asphyxiation Hazard.** Follow these instructions and the installation instructions included by the original polypropylene venting component manufacturer, Centrotherm. Failure to do so could cause products of combustion to enter the building, resulting in severe property damage, personal injury or death. Where a conflict arises between Centrotherm instructions and these instructions, the more restrictive instructions shall govern.
- **Do not mix vent components or joining methods for listed manufacturers.**
- **Examine all components for possible shipping damage prior to installation.**
- **All condensate that forms in the vent must be able to drain back to the boiler.**

2. Assemble the vent system, starting at the boiler:

- a. The vent adaptor has two different inside diameters. The smaller, lower, inside diameter accepts 3" nominal Innoflue (Figure 7.27). A locking ring in the adaptor prevents the vent pipe from coming out of the adaptor once it is inserted. Lubricate the upper gasket in the vent adaptor with water and insert the first piece of 3" Innoflue into the adaptor until it bottoms out.

### NOTICE

Once a vent pipe is inserted into this adaptor, it is **IMPOSSIBLE** to remove it. Make sure the correct type of pipe is selected, and that it is of the correct length, before inserting it into the vent adaptor.

- b. If 2" Innoflue is to be used for the vent system, reduce the first piece of 3" Innoflue installed in Step (a) to 2" using Centrotherm # ISRD0302. Otherwise assemble the next piece of 3" Innoflue.
- c. For each joint, verify that the gasket is evenly seated in the bell (female) end of the pipe. Lubricate this gasket with Centrocerin # IACE50. Slide a connector ring over the male end of the pipe to be joined as shown in Figure 7.44. Push the male end of the next section of pipe into the bell until it bottoms out, then back out 1/4" to provide room for thermal expansion. Push hook on connecting ring over the bell end of the first section of pipe as shown in Figure 7.44.
- d. Assemble the rest of the vent system per the manufacturer's installation instructions, being sure to pitch horizontal sections back towards the boiler 5/8"/ft.
- e. Support each horizontal pipe section with a minimum of one wall strap each and at intervals not exceeding 39in.

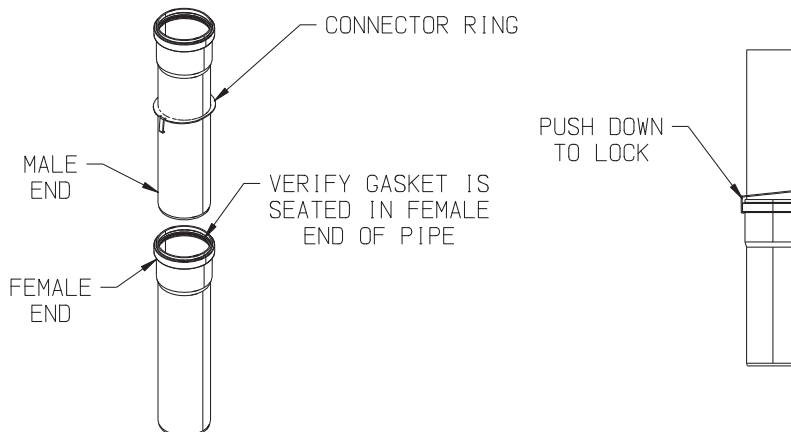

FIGURE 7.44: INNOFLUE CONNECTOR RING INSTALLATION

3. Installation of Air Intake System - Start assembly of the PVC air intake system at the boiler. Assembly of the air intake system is done in the same manner as the vent system except as follows:
  - a. Drill a 7/32" clearance hole into the front side of the air intake adapter. Insert the first piece of PVC air intake pipe into the air intake connection and drill a 1/8" tap hole into the PVC which lines up with the 7/32" clearance hole and secure them together with a #10 x 1" sheet metal screw. Seal the joint between the intake pipe and the adaptor with RTV.
  - b. All intake piping may be PVC.
  - c. There is a 0" minimum clearance between the air intake piping and all types of construction.
  - d. To the extent possible, pitch horizontal air intake piping towards the outside.



## WARNING

**Asphyxiation Hazard. Vent systems made by Centrotherm rely on gaskets for proper sealing. When this vent system is used, take the following precautions:**

- **Make sure that gasket is in position and undamaged in the female end of the pipe.**
- **Make sure that both the male and female pipes are free of damage prior to assembly.**
- **Only cut vent pipe as permitted by the vent manufacturer in accordance with their instructions. When pipe is cut, the cut end must be square and carefully de-burred prior to assembly.**
- **Use connector rings at all vent pipe joints.**

## NOTICE

**The venting system must be free to expand and contract and supported in accordance with the installation instructions included by the original polypropylene venting component manufacturer, Centrotherm. Polypropylene pipe sections must be disengaged 1/4 in. (5mm) per joint to allow for thermal expansion.**

4. Installation of Horizontal Fitting Terminals (Terminal Option A):
  - a. See Figure 7.45 for proper orientation of twin pipe horizontal terminals. Outer edge of end pipe must be 10" or less from the wall surface. (Figure 7.5)
  - b. Use plain end UV stabilized Centrotherm 2" pipe # ISEP02 or ISEP0239 or 3" pipe # ISEP03 or ISEP0339 and insert Centrotherm Bird Screen #IASPP02 or #IASPP03 in the end of the pipe.
  - c. Add PVC intake per instructions from Part VII-F.
5. Installation of Vertical Fitting Terminals (Terminal Option H):
  - a. See Figure 7.46 for the proper orientation of twin pipe vertical terminals.
  - b. Use plain end UV stabilized Centrotherm 2" pipe # ISEP02 or ISEP0239 or 3" pipe # ISEP03 or ISEP0339 and insert Centrotherm Bird Screen #IASPP02 or #IASPP03 in the end of the pipe.
  - c. A 180° bend (or two 90° elbows) are installed on the top of the air intake pipe. If two 90° elbows are used, the rodent screen provided can be installed between them (Figure 7.46). If a 180° bend is used, install the rodent screen in the open side of the bend, using a ring made of PVC pipe. If desired, the termination fittings can be attached to the end of the intake pipes with field supplied stainless steel screws so that they can be later removed for cleaning and inspection. If this is done, drill a clearance hole in these fittings and a tap hole in the end of the intake pipes to accept these screws.
  - d. Use roof flashings and storm collars to prevent moisture from entering the building. Seal the roof flashing to the roof using generally accepted practice for the type of roof on the installation. Apply RTV to seal the storm collars to the vent and intake pipes.

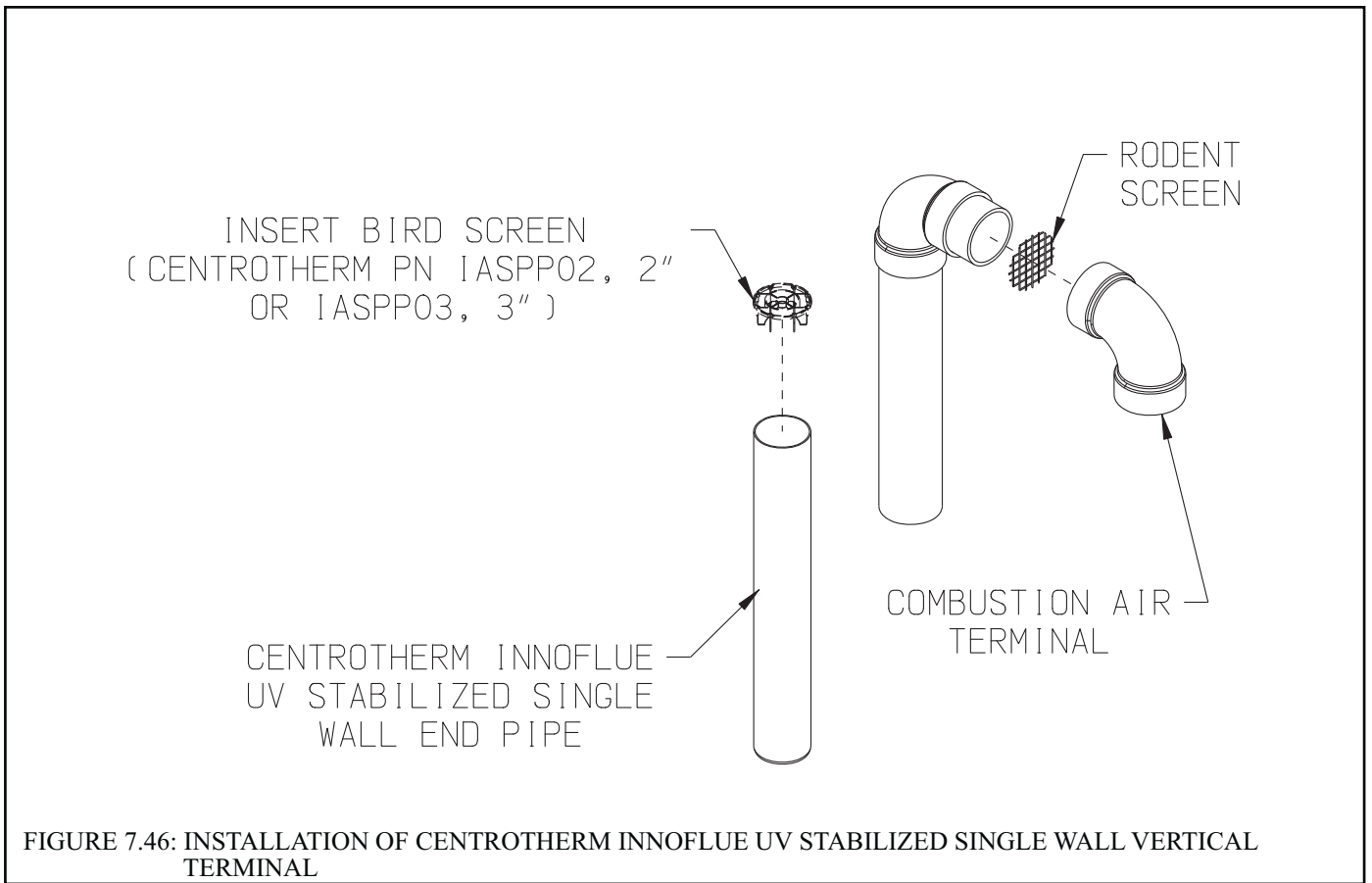
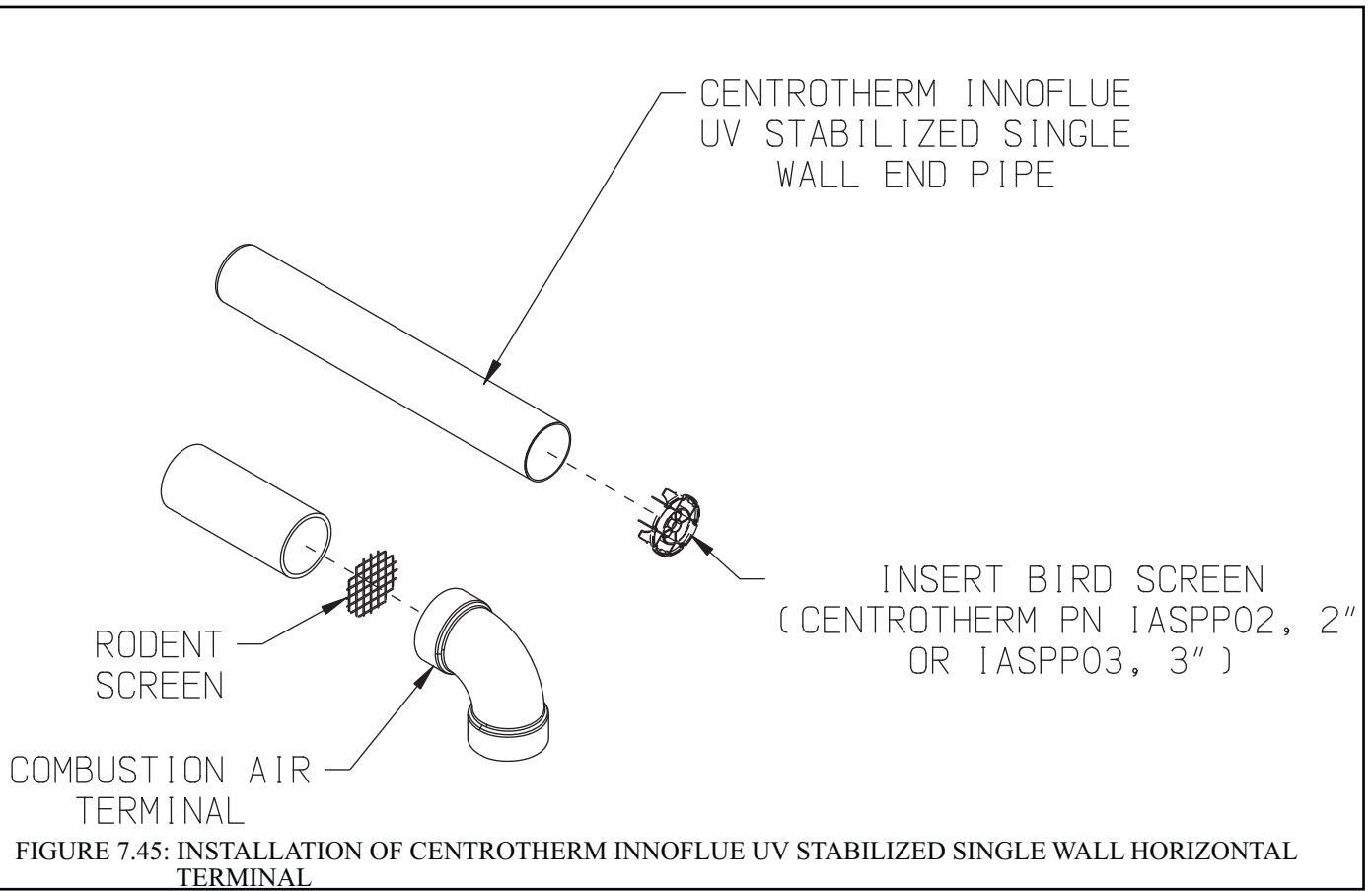

6. Installations using InnoFlue Flex (Vent Options 20,21,37,38):



## WARNING

**Asphyxiation Hazard. When using InnoFlue Flex, observe the following precautions:**

- **InnoFlue Flex may be damaged by handling at low temperatures. Do not bend, uncoil, or attempt to install if it has been stored at a temperature below 42F without allowing it to warm to a higher temperature first.**
- **Do not bend InnoFlue Flex more than 45 degrees.**
- **Instructions below reference the Centrotherm InnoFlue instruction manual. Not all vent configurations shown in the Centrotherm manual are approved for use with this boiler.**

Refer to Centrotherm InnoFlue Instructions for assembly of all flex components including the chimney cap and the adaptor to rigid InnoFlue at the base of the masonry or B vent chimney. In addition, observe the following requirements:

- a) Refer to the appropriate Vent option in Tables 7.13b or 7.21 for a list of the principle flex components required. Rigid vent pipe by the same manufacturer will also be required for the run from the boiler to the base of chimney.
- b) Masonry chimneys cannot be used for an air chase
- c) B vent chimneys can only be used for an air chase (Vent options 20, 21) if the B vent has the minimum size shown in Table 7.13b and is fully accessible for sealing of all joints and seams.
- d) When Vent Options 20, 21 are used, install a Tee of the same size at the base of the vent. Route the smooth section of InnoFlue Flex (3") or Flex Adaptor (2") through a cap in the base of this Tee. Use a Centrotherm IAWP2P or IAWP03B wall plate and RTV to seal this penetration. Install the Base Support using the Base support bracket as described in the InnoFlue installation manual.

Connection of the PVC air intake pipe to the side outlet of the tee is made using a cap and a PVC socket x male thread adaptor (2" or 3", depending on the Vent Option). Cut a clearance hole in the cap for the male threads. Secure the adaptor to the cap using a 2" or 3" electrical conduit lock nut. Seal all joints with RTV.



## I. Condensate Trap and Drain Line

All condensate which forms in the boiler or vent system passes through the heat exchanger and out of a bottom drain port which is connected to the condensate trap with a hose. This trap allows condensate to drain from the heat exchanger while retaining flue gases in the boiler. This trap is an integral part of the boiler but must be connected to a drain pipe as shown in Figure 7.47. A length of corrugated tubing is supplied with the boiler and is connected to the trap as shown in Figure 7.35. Note the following when disposing of the condensate:

1. If the corrugated condensate drain line must be extended, construct the extension from PVC or CPVC pipe. Insert the hose provided with the boiler into the end of the extension as shown in Figure 7.47.
2. Condensate is slightly acidic. Do not use metallic pipe or fittings in the condensate drain line. Do not route the drain line through areas that could be damaged by leaking condensate.
3. Some jurisdictions may require that the condensate be neutralized before being disposed of. Dispose of condensate in accordance with local codes.
4. Do not route, or terminate, the condensate drain line in areas subjected to freezing temperatures.
5. If the point of condensate disposal is above the trap, it will be necessary to use a condensate pump to move the condensate to the drain. In such cases, select a condensate pump that is approved for use with condensing boilers. If overflow from this pump would result in property damage, select a pump with an overflow switch and use this switch to shut down the boiler. Alternatively, if heat is a necessity, use the overflow switch to trigger an alarm.
6. Do not attempt to move the trap from the location shown in Figure 7.47. Do not attempt to substitute another trap for the one provided with the boiler.
7. The vent shown in Figure 7.47 must be left open for the trap to work properly.



### WARNING

**Asphyxiation Hazard. Failure to install the condensate drain in accordance with the above instructions could cause flue gas to enter the building, resulting in personal injury or death.**

### NOTICE

- **Boiler condensate is corrosive. Route condensate drain line in a manner such that any condensate leakage will not cause property damage.**
- **Some jurisdictions may require that condensate be neutralized prior to disposal.**
- **Use materials approved by the authority having jurisdiction.**

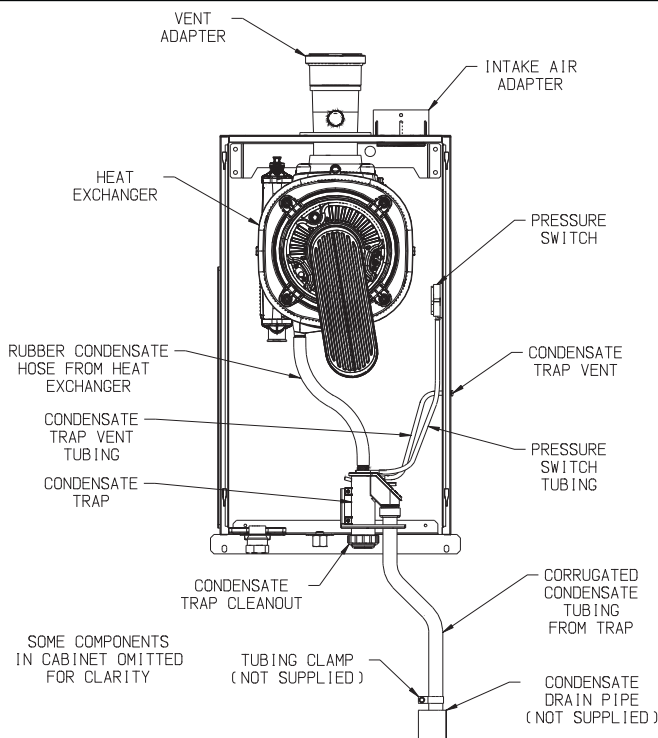

FIGURE 7.47: CONDENSATE PIPING ARRANGEMENT

## J. Removing an Existing Boiler From a Common Chimney

This section only applies if this boiler is replacing an existing boiler that is being removed from a common chimney.

In some cases, when an existing boiler is removed from a common chimney, the common venting system may be too large for the remaining appliances. At the time of removal of an existing boiler, the following steps shall be followed with each appliance remaining connected to the common venting system placed in operation, while the other appliances remaining connected to the common venting system are not in operation.

- (a) Seal any unused openings in the common venting system.
- (b) Visually inspect the venting system for proper size and horizontal pitch and determine there is no blockage or restriction, leakage, corrosion and other deficiencies which could cause an unsafe condition.
- (c) Insofar as practical, close all building doors and windows and all doors between the space in which all the appliances remaining connected to the common venting system are located and other spaces of the building. Turn on clothes dryers and any appliance not connected to the common venting system. Turn on any exhaust fans, such as range hoods and bathroom exhausts, so they will operate at maximum speed. Do not operate a summer exhaust fan. Close fireplace dampers.
- (d) Place in operation the appliance being inspected. Follow the lighting instructions. Adjust thermostat so the appliance will operate continuously.
- (e) Test for spillage at the draft hood relief opening after 5 minutes of main burner operation. Use the flame of a match or candle, or smoke from a cigarette, cigar, or pipe.
- (f) After it has been determined that each appliance remaining connected to the common venting system properly vents when tested as outlined above, return doors, windows, exhaust fans, fireplace dampers and any other gas-burning appliances to their previous condition of use.
- (g) Any improper operation of the common venting system should be corrected so the installation conforms with the National Fuel Gas Code, ANSI Z223.1. When re-sizing any portion of the common venting system, the common venting system should be re sized to approach the minimum size as determined using the appropriate tables in Part 11 of the National Fuel Gas Code, ANSI Z223.1.



### **WARNING**

**Never common vent this boiler with other appliances.**

Au moment du retrait d'une chaudière existante, les mesures suivantes doivent être prises pour chaque appareil toujours raccordé au système d'évacuation commun et qui fonctionnent alors que d'autres appareils toujours raccordés au système d'évacuation ne fonctionnent pas:

- (a) Sceller toutes les ouvertures non utilisées du système d'évacuation.
- (b) Inspecter de façon visuelle le système d'évacuation pour déterminer la grosseur et l'inclinaison horizontale qui conviennent et s'assurer que le système est exempt d'obstruction, d'étranglement, de fuite, de corrosion et autres défaillances qui pourraient présenter des risques.
- (c) Dans la mesure du possible, fermer toutes les portes et les fenêtres du bâtiment et toutes les portes entre l'espace où les appareils toujours raccordés au système d'évacuation sont installés et les autres espaces du bâtiment. Mettre en marche les sècheuses, tous les appareils non raccordés au système d'évacuation commun et tous les ventilateurs d'extraction comme les hottes de cuisinière et les ventilateurs des salles de bain. S'assurer que ces ventilateurs fonctionnent à la vitesse maximale. Ne pas faire fonctionner les ventilateurs d'été. Fermer les registres des cheminées.
- (d) Mettre l'appareil inspecté en marche. Suivre les instructions d'allumage. Régler le thermostat de façon que l'appareil fonctionne de façon continue.
- (e) Faire fonctionner le brûleur principal pendant 5 min ensuite, déterminer si le coupe-tirage déborde à l'ouverture de décharge. Utiliser la flamme d'une allumette ou d'une chandelle ou la fumée d'une cigarette, d'un cigare ou d'une pipe.
- (f) Une fois qu'il a été déterminé, selon la méthode indiquée ci-dessus, que chaque appareil raccordé au système d'évacuation est mis à l'air libre de façon adéquate. Remettre les portes et les fenêtres, les ventilateurs, les registres de cheminées et les appareils au gaz à leur position originale.
- (g) Tout mauvais fonctionnement du système d'évacuation commun devrait être corrigé de façon que l'installation soit conforme au National Fuel Gas Code, ANSI Z223.1/NFPA 54 et (ou) aux codes d'installation CAN/CSA-B149.1. Si la grosseur d'une section du système d'évacuation doit être modifiée, le système devrait être modifié pour respecter les valeurs minimales des tableaux pertinents de l'appendice F du National Fuel Gas Code, ANSI Z223.1/NFPA 54 et (ou) des codes d'installation CAN/CSA-B149.1.

This page is  
intentionally left blank.

## VIII Gas Piping



### WARNING

**Explosion Hazard. Failure to properly pipe gas supply to boiler may result in improper operation or leaks of flammable gas.**

- **Gas supply to boiler and system must be absolutely shut off prior to installing or servicing boiler gas piping.**
- **Always assure gas piping is absolutely leak free and of the proper size and type for the connected load.**
- **Use a thread compound compatible with liquefied petroleum gas. Failure to use proper thread compounds on all gas connectors may result in leaks of flammable gas.**
- **If inlet pressure is above 1/2 psig (3.4 kPa) an additional gas pressure regulator is required. Consult gas supplier.**
- **Size corrugated stainless steel tubing (CSST) to ensure proper capacity and minimize flow restrictions.**

Gas piping to the boiler must be sized to deliver adequate gas for the boiler to fire at the nameplate input at an inlet pressure between the minimum and maximum values shown in Table 8.2. When sizing, also consider other existing and expected future gas utilization equipment (i.e. water heater, cooking equipment). For more information on gas line sizing, consult the utility or the *National Fuel Gas Code*, NFPA54/ANSI Z223.1, and/or CAN/CSA B149.1 *Natural Gas and Propane Installation Code*.

Figure 8.1 shows typical gas piping connection to the boiler. A sediment trap must be installed upstream of all gas controls. Install the factory provided manual shut-off valve outside the jacket with a ground joint union as shown. All above ground gas piping upstream from manual shut-off valve must be electrically continuous and bonded to a grounding electrode. Refer to *National Electrical Code*, NFPA 70.

The boiler and its gas connection must be leak tested before placing the boiler in operation. When doing this, the boiler and its individual shut-off must be disconnected from the rest of the system during any pressure testing of that system at pressures in excess of 1/2 psi (3.5kPa). When pressure testing the gas system at pressures of 1/2 psi (3.5kPa) or less, isolate the boiler from the gas supply system by closing its individual manual shut-off valve. Locate leaks using approved combustible gas non-corrosive leak detector solution.



### DANGER

**Explosion Hazard. Do not use matches, candles, open flames or other ignition source to check for leaks.**



### WARNING

**If gas pressure in the building is above 1/2 psig (3.4 kPa), an additional gas pressure regulator is required. Using one additional regulator for multiple gas appliances may result in unsafe operation. The additional regulator must be able to properly regulate gas pressure at the input of the smallest appliance. If the regulator can not do this, two or more additional regulators are required. Consult regulator manufacturer and/or local gas supplier for instructions and equipment ratings.**



## CAUTION

- Support the weight of the gas line piping independently from the boiler gas connection fitting located on the bottom of the boiler.
- If an additional regulator is used to reduce boiler inlet pressure below 1/2 psig (3.4 kPa) it must be at least 6 to 10 feet upstream of the boiler.
- It is very important that the gas line is properly purged by the gas supplier or utility company.

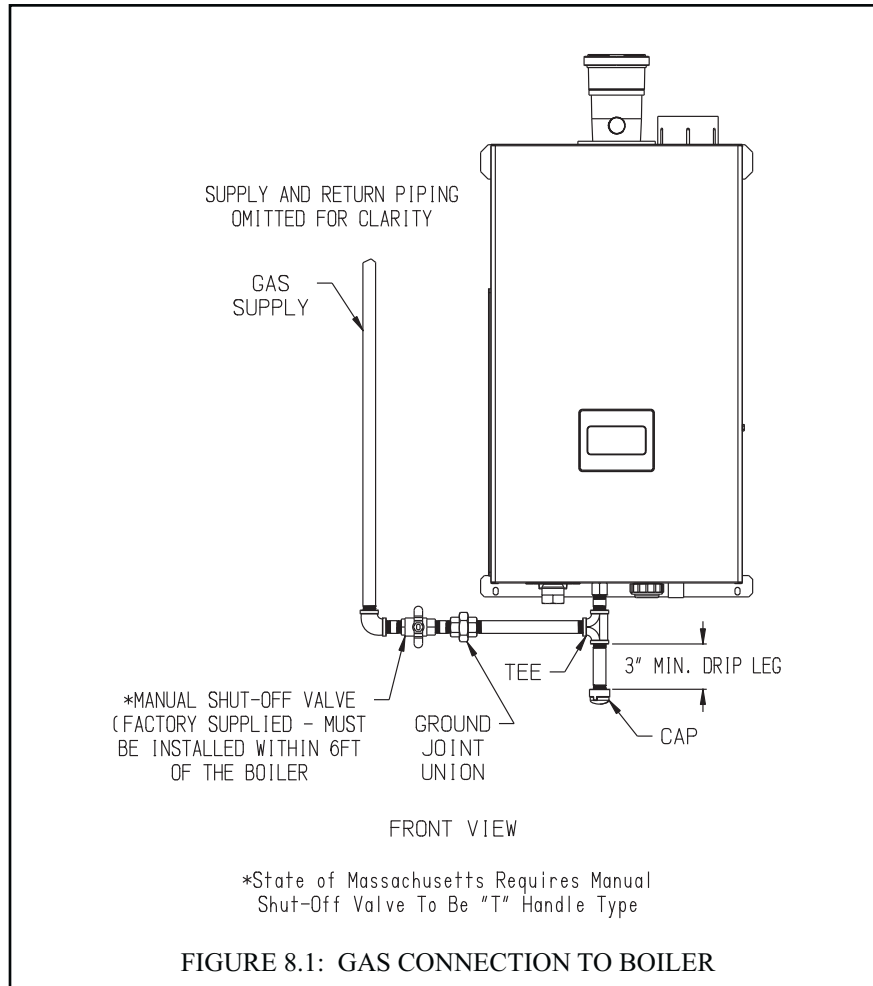

TABLE 8.2: MINIMUM AND MAXIMUM INLET PRESSURES

MODEL	MAX (NATURAL & LP)	MIN (NATURAL)	MIN (LP)
080MBH	14.0"	2.5"	11.0"
100MBH	14.0"	2.5"	11.0"
120MBH	14.0"	2.5"	11.0"
150MBH	14.0"	2.5"	11.0"
180MBH	14.0"	2.5"	11.0"

## IX System Piping

### A. General System Piping Precautions



#### WARNING

- **Failure to properly pipe boiler may result in improper operation and damage to boiler or structure.**
- **Install boiler so that the gas ignition system components are protected from water (dripping, spraying, rain, etc.) during boiler operation and service (circulator replacement, etc.).**
- **Oxygen contamination of boiler water will cause corrosion of iron and steel boiler components and can lead to boiler failure. Warranty does not cover problems caused by oxygen contamination of boiler water or scale (lime) build-up caused by frequent addition of water.**

### WATER QUALITY AND BOILER WATER ADDITIVES IMPORTANT NOTE

The heat exchanger used in this boiler is made from stainless steel coils having relatively narrow waterways. Once filled with system water, it will be subjected to the effects of corrosion, as well as fouling from any debris introduced from the system. Take the following precautions to minimize the chance of severe heat exchanger damage caused by corrosion and/or overheating:

1 Flush the system before connecting the boiler - In a replacement installation, flushing the system will remove impurities, such as sediment, solder flux, metal shavings, and traces of old boiler additives. Even if the system is new, do not omit this step – new systems will contain flux and may even contain some of the other impurities listed above. Flush the system completely and repeat if necessary to completely remove these contaminants. If necessary, a cleaning agent may be used to assist in system cleaning. See Part XI (“Start-up and Check-out”) for recommended cleaners.

2. Make sure that the system is tight - This is the single most important guideline. Tap water contains dissolved oxygen which causes corrosion. In a tight system, this oxygen comes out of solution and is quickly removed from the system through the automatic air vent. The system then remains essentially free of oxygen. If the system is not tight, however, frequent additions of make-up water can expose the heat exchanger to oxygen on a continuous basis. In addition, frequent additions of hard make-up water can cause calcium deposits to collect in the heat exchanger, causing severe damage. To minimize additions of make-up water:

- Inspect the system thoroughly for leaks before placing it in service.
- If the system includes underground piping, or other piping in which a leak might go undetected, consider isolating the boiler from the system with a heat exchanger.
- Make sure that the expansion tank is properly sized and in good condition. If it is not, the relief valve may open frequently, resulting in regular additions of make-up water.
- If an automatic fill valve is installed, installation of a water meter in the fill line is strongly recommended so that routine additions of make-up water can be detected and their cause corrected.

3. Non-Metallic Tubing - Even if the system is tight, oxygen can be introduced into the system through some types of non-metallic tubing used in radiant or snow melt systems. Other nonmetallic tubing is equipped with an oxygen barrier to prevent migration of oxygen into the water. If the boiler is to be installed in a system containing non-metallic tubing without an oxygen barrier, it must be isolated from the boiler with a heat exchanger as shown in Figure 9.10.

4. Water Chemistry, Antifreeze, and Boiler Water Additives – Improper boiler water chemistry can cause the heat exchanger damage described above, as well as deterioration of seals. Observe the water chemistry requirements shown in Part XI (“Start-up and Check-out”).

## B. Near Boiler Piping Design

Proper operation of this boiler requires that the water flow rate through it remain within the limits shown in Table 9.1 any time the boiler is firing. At flow rates below the minimum shown, the boiler's flow switch and/or temperature rise limit function may prevent the boiler from firing. Flow rates through the boiler in excess of the maximum shown in Table 9.1 can result in excessive noise or erosion damage to piping

There are two basic methods that can be used to pipe this boiler into the system. Method #1 (primary-secondary piping) is always preferred. Additional information on hydronic system design can be found in the *I=B=R Guide RHH* published by the Air-Conditioning, Heating and Refrigeration Institute (AHRI).

**Table 9.1: Flow Limitations**

Model	Flow (GPM)	
	Minimum	Maximum
80MBH	5.0	13.3
100MBH	5.1	13.3
120MBH	6.2	13.3
150MBH	7.7	13.3
180MBH	9.3	13.3

### Method 1: Primary/Secondary Piping (Strongly Recommended)

This method can be used in heat-only applications as shown in Figure 9.2 or with an indirect water heater as shown in Figure 9.3A or Figure 9.3B. In this system, the flow rate through the boiler ("secondary loop") is completely independent of the flow rate through the system ("primary loop"). Use the following guidelines to ensure that the boiler will have the required flow shown in Table 9.1 regardless of the flow in the heating system.

1) System Loop Piping - Size the system circulator and piping to obtain the design flow rate through the heating system as you would on any other heating system. All piping between the expansion tank and secondary connection tees must be at least 1". In order to keep the flow rates in the system and boiler loops independent of each other, provide at least 8 diameters of straight pipe upstream of the first tee and 4 diameters downstream of the second tee. Keep the distance between the expansion tank and the first secondary tee as short as practical.

2) Boiler Loop Piping – All boilers are supplied with a built in circulator which will deliver the flow required by Table 9.1 provided both of the following conditions are met:

- All piping in the boiler loop has a nominal size of at least 1"
- The equivalent length of all piping in the boiler loop is 60ft or less.

To verify that the 60ft, equivalent length is not exceeded, do the following:

- a) Count all fittings in the planned boiler loop (the shaded piping in Figure 9.6). In doing so, do not count the secondary connection tees, unions, or the fittings supplied with the boiler (these have already been accounted for).
- b) Using Table 9.4, find the equivalent lengths of all fittings in the secondary loop. Total these equivalent lengths and add them to the total length of planned straight pipe in the secondary loop.
- c) The result is the total equivalent length of the planned boiler loop. If the equivalent length calculated in (b) is under the limit shown in Table 9.5, the boiler pump will achieve a flow rate and temperature rise approximately equal to that shown in this table. Otherwise, the equivalent length must be reduced.

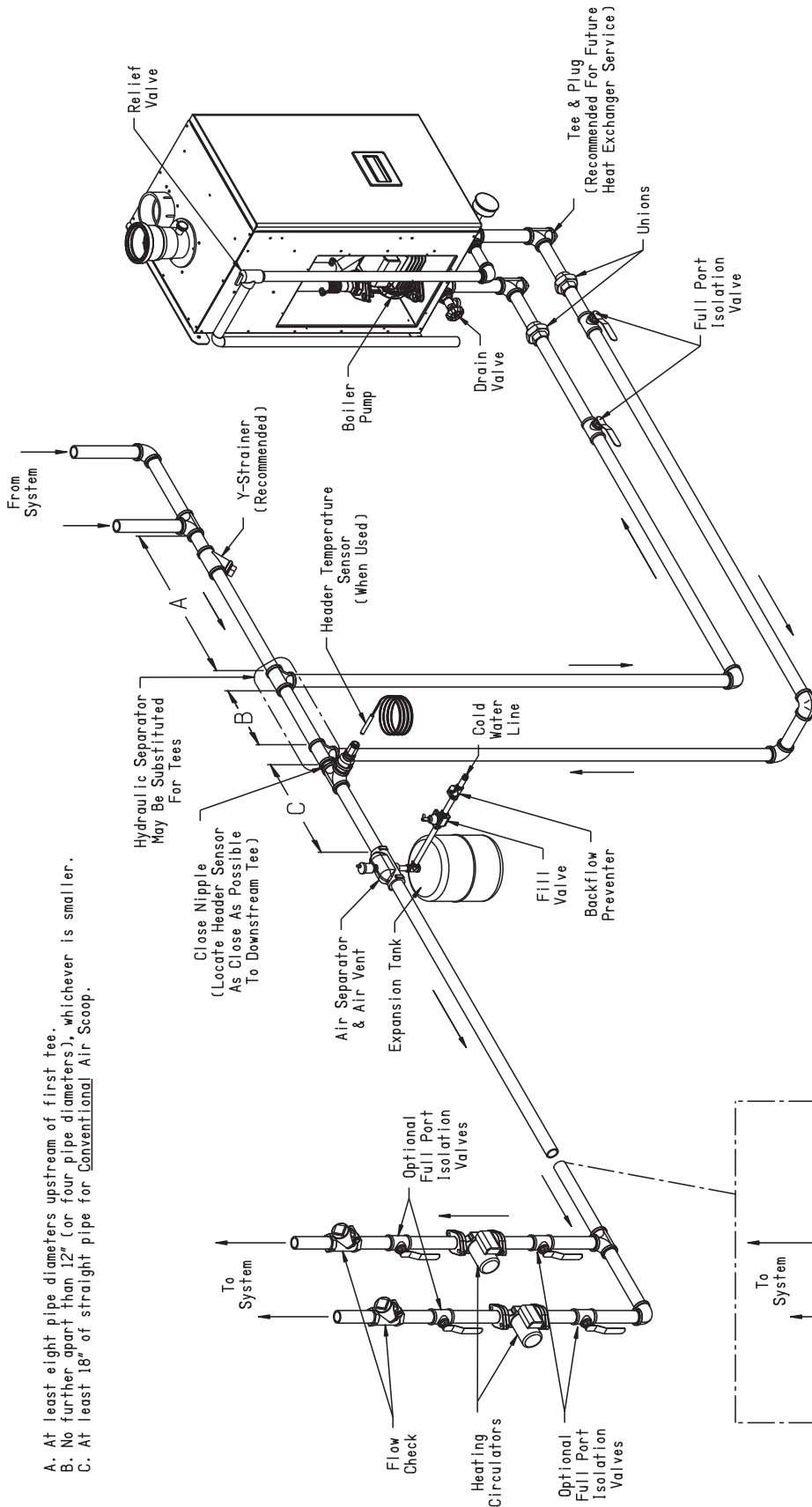

- A. At least eight pipe diameters upstream of first tee.
- B. No further apart than 12" (or four pipe diameters), whichever is smaller.
- C. At least 18" of straight pipe for Conventional Air Scoop.

Notes:  
 1. Boiler Pump Located Inside Boiler Jacket.  
 2. Manual Air Vent Located On Top Of Heat Exchanger. See Figure 11.1.

**CAUTION**  
 It is the installers responsibility to select boiler piping configurations that provide the proper flow rates and performance for the boiler.

FIGURE 9.2: PIPING METHOD #1 - NEAR BOILER PIPING - HEATING ONLY



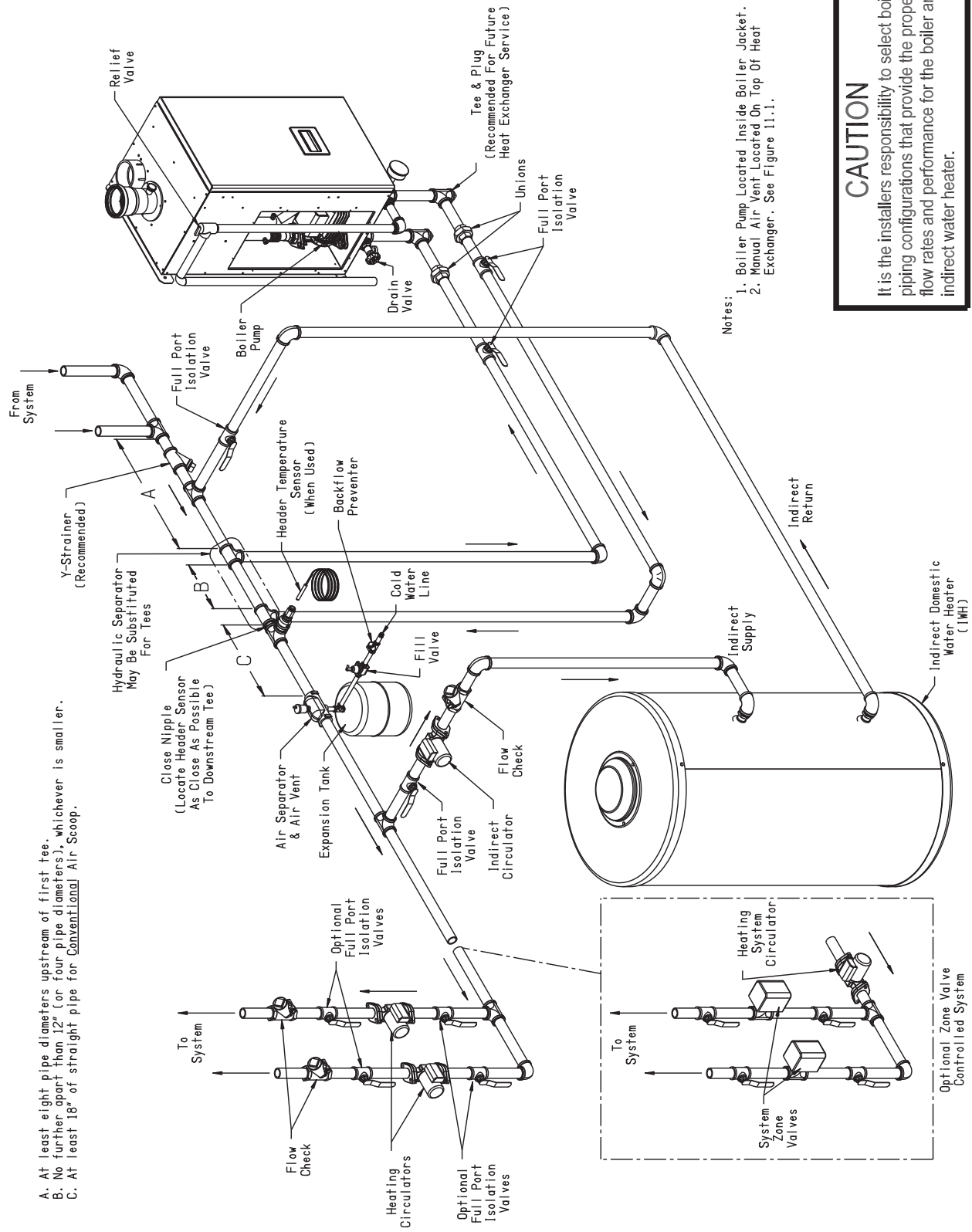

- A. At least eight pipe diameters upstream of first tee.
- B. No further apart than 12" (or four pipe diameters), whichever is smaller.
- C. At least 18" of straight pipe for [Conventional] Air Scoop.

Notes:

1. Boiler Pump Located Inside Boiler Jacket.
2. Manual Air Vent Located On Top Of Heat Exchanger. See Figure 11.1.

**CAUTION**  
 It is the installers responsibility to select boiler piping configurations that provide the proper flow rates and performance for the boiler and indirect water heater.

FIGURE 9.3A: PIPING METHOD #1 - NEAR BOILER PIPING - HEATING PLUS INDIRECT WATER HEATER (IWH OFF PRIMARY LOOP)

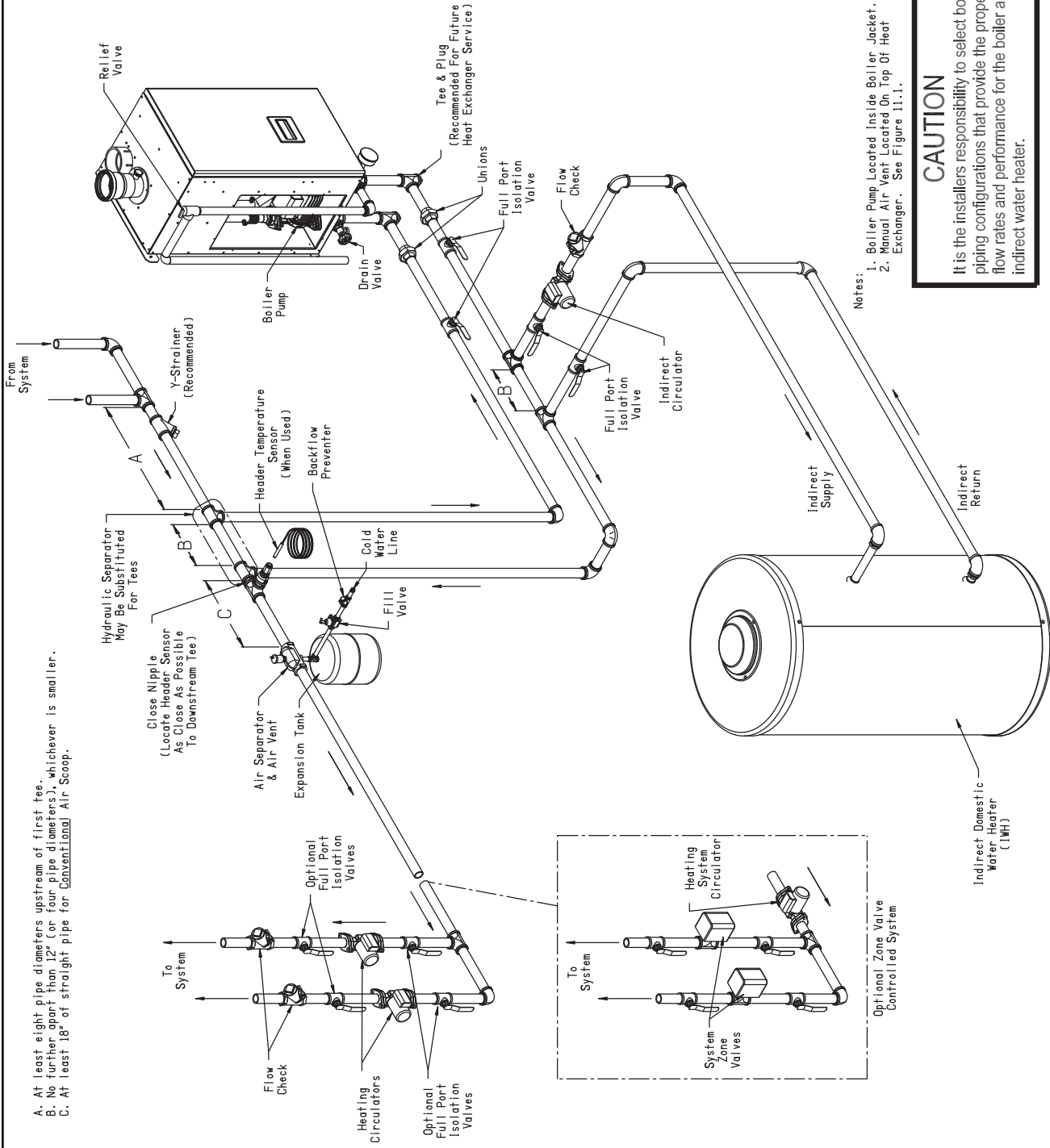

- A. At least eight pipe diameters upstream of first tee.
- B. No further apart than 12" (or four pipe diameters), whichever is smaller.
- C. At least 18" of straight pipe for Conventional Air Scoop.

- Notes:
1. Boiler Pump Located Inside Boiler Jacket.
  2. Manual Air Vent Located On Top Of Heat Exchanger. See Figure 11.1.

**CAUTION**  
 It is the installers responsibility to select boiler piping configurations that provide the proper flow rates and performance for the boiler and indirect water heater.

FIGURE 9.3B: PIPING METHOD #1 - NEAR BOILER PIPING - HEATING PLUS INDIRECT WATER HEATER (IWH OFF BOILER LOOP)

Example – A 120MBH model is to be connected to a heating system as shown in Figure 9.6. A total of 20 ft of straight pipe will be installed between the boiler and the system loop.

Count all fittings in the boiler loop (shaded in Figure 9.6):

3 90 Elbows

2 Turn in Tee (under boiler- primary-secondary tees not counted)

2 Isolation Valves

1 Y Strainer having a Cv of 30.

Note: Unions, Secondary Connection Tees, and factory supplied fittings are ignored.

Calculate total equivalent length from Table 9.4:

$$20\text{ft Straight Pipe} + 3 \text{ Elbows} \times 2.8 + 2 \text{ Turn in Tee} \times 5.5 + 2 \text{ Valves} \times 0.7 = 40.8 \text{ Equivalent Feet}$$

Since the total equivalent length is less than 60ft, flow through boiler loop meets requirements in Table 9.1

3) Indirect Water Heater Loop Piping – If an indirect water heater is used, install it as shown in Figures 9.3A or 9.3B. The piping shown in Figures 9.3A and 9.3B is functionally identical. Use the variation that is most compatible with the existing piping on the job. Refer to the indirect water heater installation manual for the proper sizing the indirect water heater loop pump and piping.

4) Hydraulic Separators – Hydraulic separators serve the same purpose as the closely spaced tees connecting the boiler and system loops in Figure 9.1. They also generally provide effective connection points for automatic air elimination devices and an expansion tank. These separators are available from several sources and may be used in place of the closely spaced tees shown in Figures 9.2, 9.3A or 9.3B. When a hydraulic separator is used in place of the tees, the 60ft equivalent length limitation still applies. Select a hydraulic separator having 1” or larger boiler connections that is designed for the boiler flow rates shown in Table 9.1.

**Table 9.4: Equivalent Lengths for Selected Valves and Fittings**  
(May Be Used for Copper or Threaded Fittings)

Fitting	Pipe Size	Equivalent Length (ft)
90° Elbow	1”	2.8
45° Elbow	1”	1.4
90° Turn in Tee	1”	5.5
Run of Tee	1”	1.8
Gate Valve (Open)	1”	0.7
Full Port Ball Valve	1”	0.7
Y-Strainer*	1”	7.0

\* Based on Cv of 20. Pressure drop through strainers varies widely. 7ft equivalent length may be assumed for strainers having a published Cv greater than 20.

**Table 9.5a: Flow Available with Boiler Loop Equivalent Length of 30ft or Less\***

Boiler Model	Approx. Flow (GPM)	Approx. Rise (°F)
80MBH	7.5	19
100MBH	8.3	22
120MBH	9.6	22
150MBH	12.9	21
180MBH	12.9	25

**Table 9.5b: Flow Available with Boiler Loop Equivalent Length of 60ft or Less\***

Boiler Model	Approx. Flow (GPM)	Approx. Rise (°F)
80MBH	7.3	20
100MBH	8.0	23
120MBH	9.2	24
150MBH	11.9	23
180MBH	11.9	27

\* For multi-speed pumps, these tables assume pump is set to highest speed.

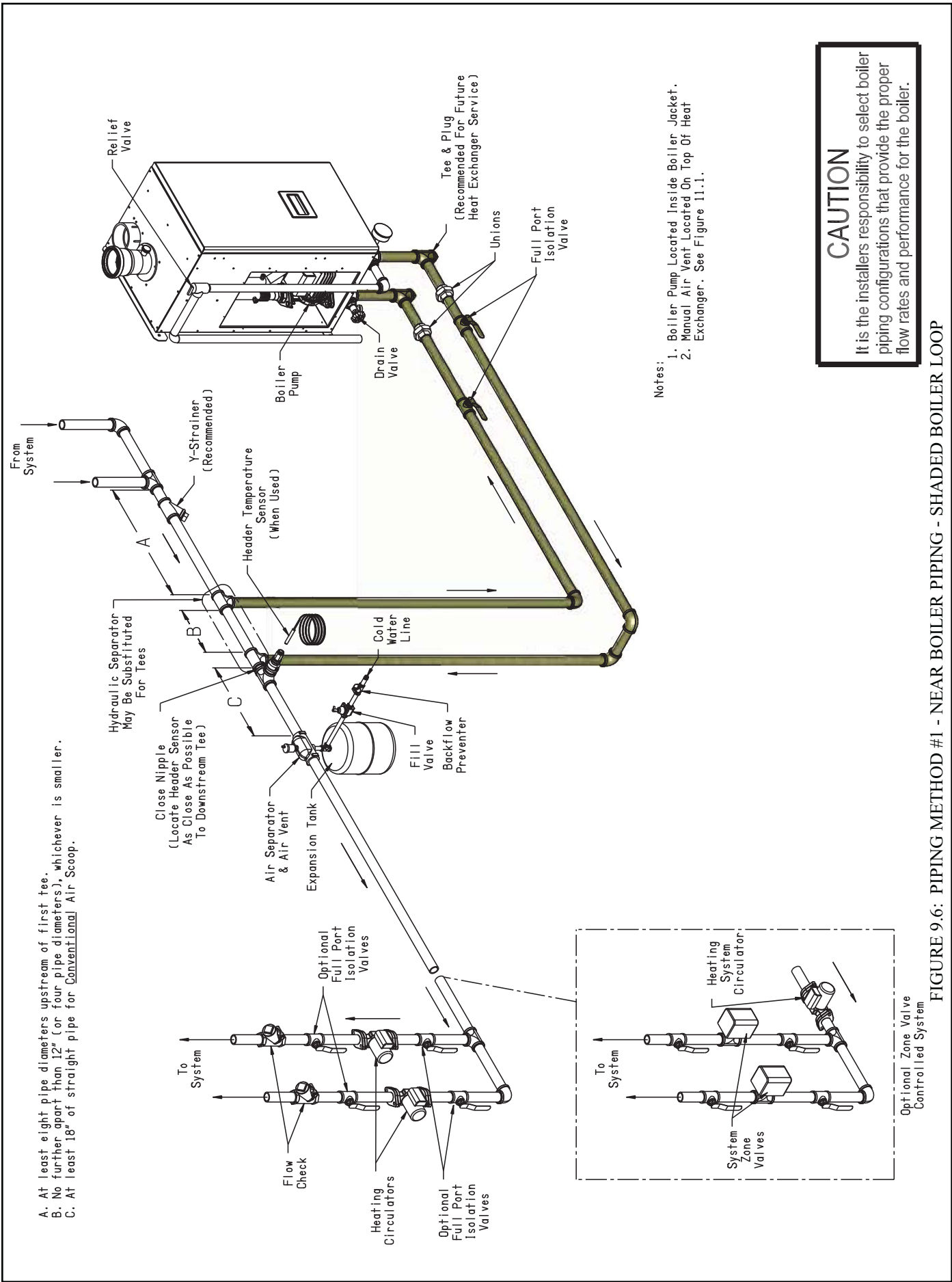

FIGURE 9.6: PIPING METHOD #1 - NEAR BOILER PIPING - SHADED BOILER LOOP

## Method 2: Direct Connection to Heating System (Generally NOT Recommended)

In some relatively rare cases it may be possible to connect this boiler directly to the heating system as is done with conventional boilers (Figure 9.7). If this is done, the flow rate through the boiler will equal the flow rate through the system. The flow rate through the system must therefore always remain within the limits shown in Table 9.1. For this reason, the pressure drop through the entire system must be known.

This method is generally not recommended because it is often very difficult to accurately calculate the pressure drop through the system. In replacement installations, it may be impossible to get an accurate measurement of the amount of piping and number of fittings in the system. In addition, if the system is zoned, the system flow may drop well below the minimum required when only one zone is calling for heat.

The one advantage to this method is its installation simplicity. It may make sense to use this method when the boiler is to be installed with a new single zone system having a low-pressure drop.

Figure 9.8 shows the performance curve for the pump in each boiler model, taking into account the pressure drop through the boiler's heat exchanger and internal piping. These curves therefore show the flow that can be achieved through the boiler as a function of the pressure drop through the connected piping. Calculation of the system pressure drop must be performed by someone having familiarity with pressure drop calculations, such as an HVAC engineer.

### NOTICE

**Where it is not possible to install a separate boiler loop, the system circulator must be sized to ensure that the flow through the boiler stays within the defined parameters to prevent overheating when the boiler is fired at its full rated input. Install a flow meter to measure the flow, or fire the boiler at full rate and ensure the boiler delta T does not exceed 35°F (19°C).**

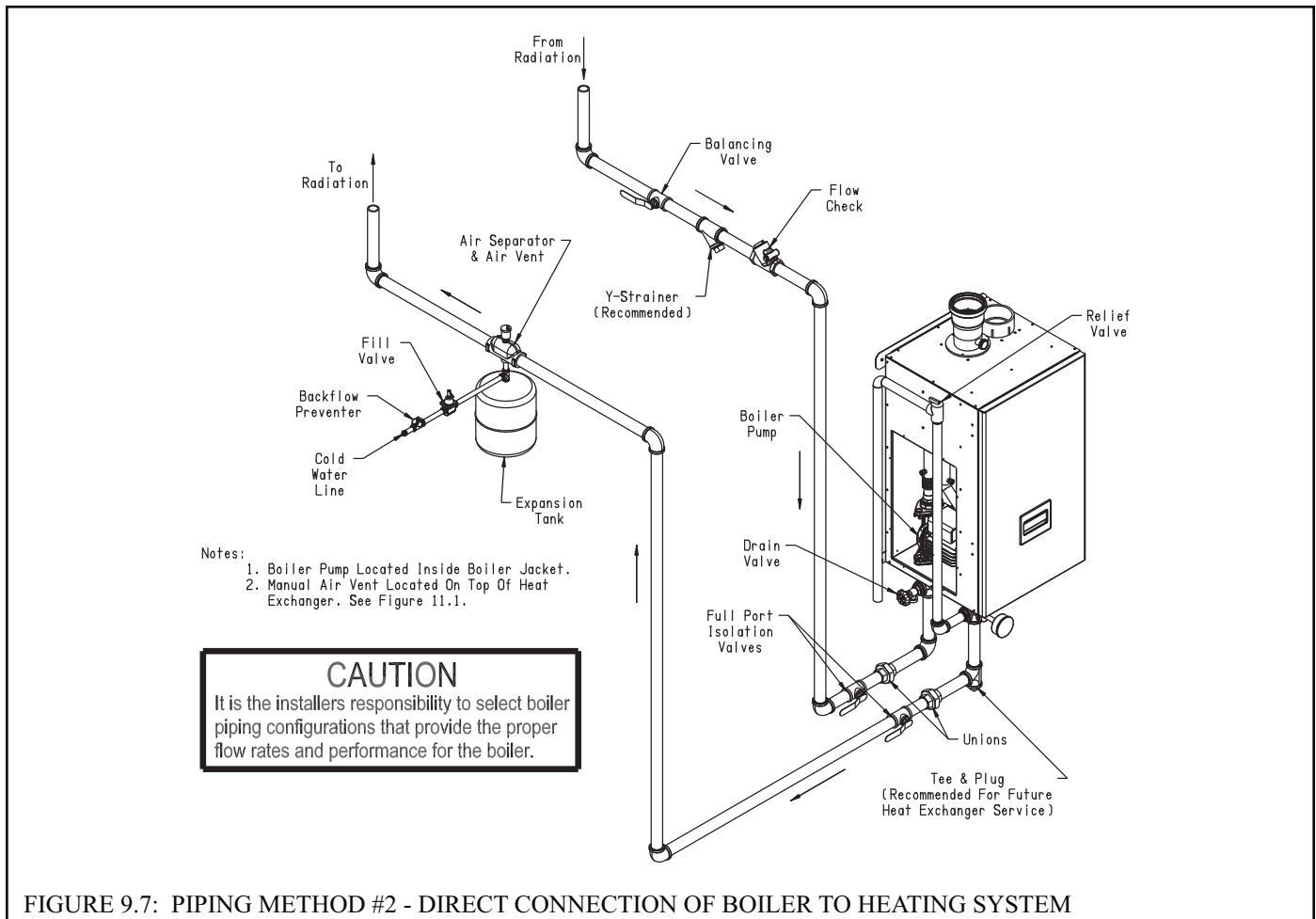
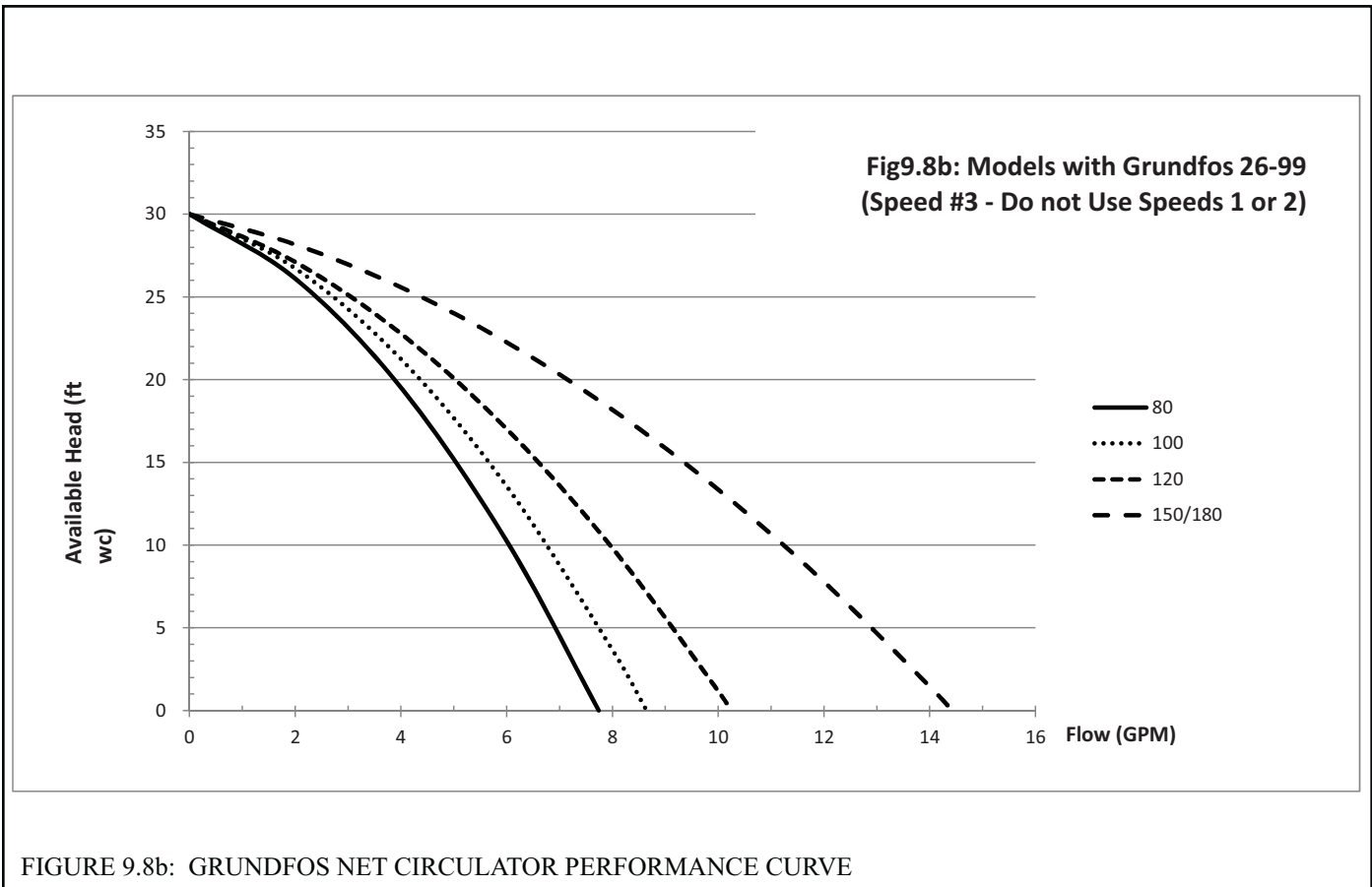
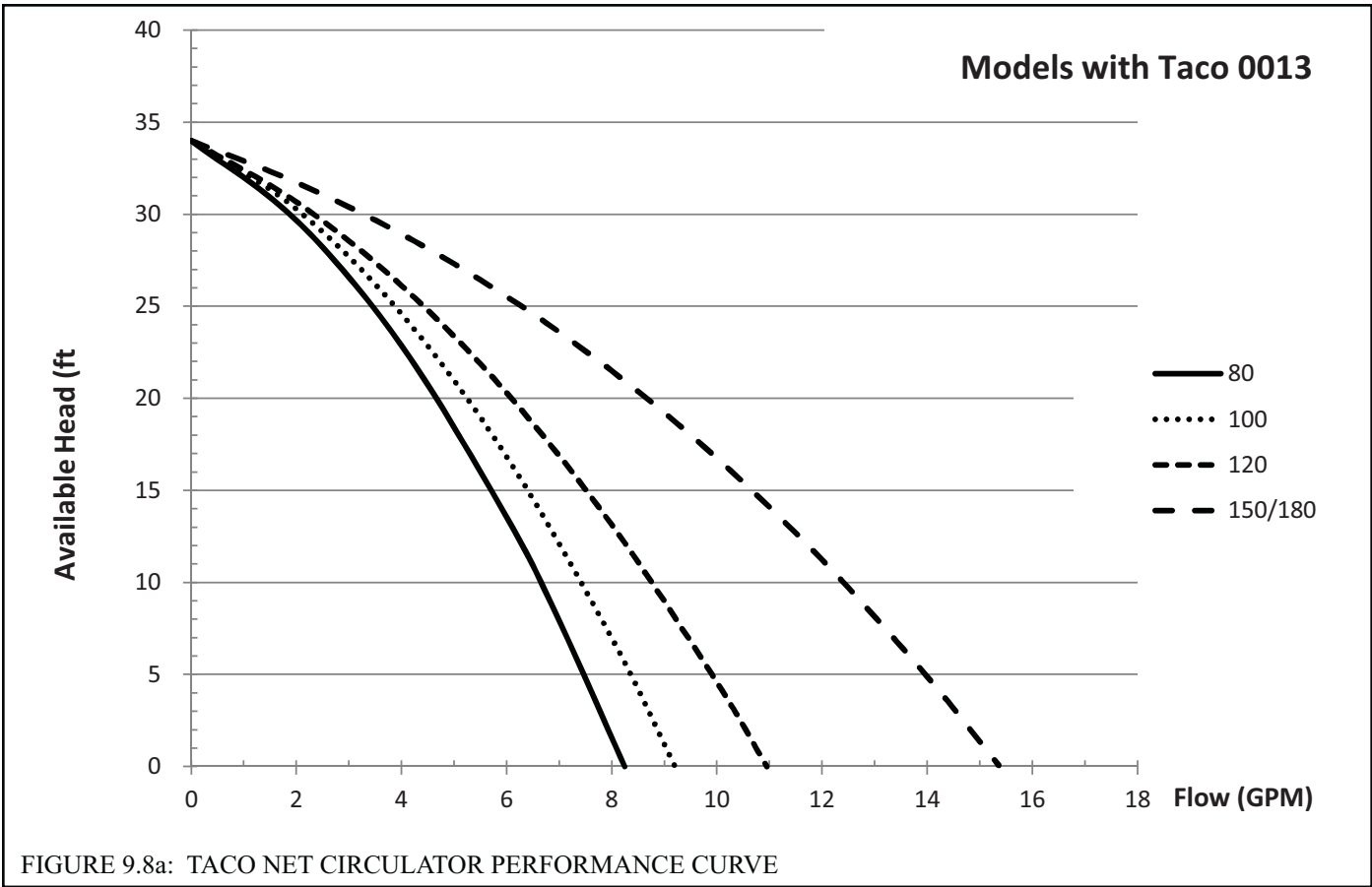

FIGURE 9.7: PIPING METHOD #2 - DIRECT CONNECTION OF BOILER TO HEATING SYSTEM



## C: Standard Piping Installation Requirements

Observe the following requirements when installing the boiler piping:

- 1) Relief Valve (Required) – The relief valve is shipped loose and must be installed in the location shown in Figure 9.9, using the side outlet Tee and other fittings provided. ASME Section IV currently requires that this relief valve be installed above the heat exchanger as shown. Pipe the outlet of the relief valve to a location where water or steam will not create a hazard or cause property damage if the valve opens. The end of the discharge pipe must terminate in unthreaded pipe. If the relief valve discharge is not piped to a drain, it must terminate at least 6” above the floor. Do not run the discharge piping through an area that is prone to freezing. The termination of the relief valve must be in an area where it is not likely to become plugged by debris.

The relief valve supplied with the boiler is set to open at 30 psi. If it is replaced, the replacement must have a setting less than or equal to the maximum allowable working pressure (MAWP) shown on the ASME data plate located on the left side of the heat exchanger behind the service access panel (Figure 9.9).



### **DANGER**

#### **Explosion / Scald Hazard**

- **Pipe relief valve discharge to a location where the potential of severe burns is eliminated.**
- **Do not install a relief valve having a setting greater than the MAWP shown on the rating plate**
- **Do not install a valve in the relief valve discharge line.**
- **Do not install relief valve in a location other than that specified by the factory.**
- **Do not plug the relief valve discharge.**

- 2) Gauge (Required) - Indicates supply water pressure and temperature. This gauge is shipped loose. Install it as shown in Figure 9.9.
- 3) Circulator (required) – The boiler loop circulator is factory installed inside the boiler cabinet. Usually at least one addition circulator (not supplied) will be required for the system to work properly. See the previous section for more information.
- 4) Expansion Tank (required) – If this boiler is replacing an existing boiler with no other changes in the system, the old expansion tank can generally be reused. If the expansion tank must be replaced, consult the expansion tank manufacturer’s literature for proper sizing.
- 5) Fill Valve (required) – Either a manual or automatic fill valve may be used, but a manual valve is preferred because it eliminates unmonitored additions of make-up water to the system. The ideal location for the fill valve is at the expansion tank.
- 6) Automatic Air Vent (required) – At least one automatic air vent is required. Manual air vents will usually be required in other parts of the system to remove air during initial fill.
- 7) Manual Reset High Limit (required by some codes) - This control is required by ASME CSD-1 and some other codes. Install the high limit in the boiler supply piping just above the boiler with no intervening valves. Set the manual reset high limit to 200°F. Wire the limit per Figure 10.2 in the Wiring section.
- 8) Isolation Valves (recommended) - Isolation valves are useful when the boiler must be drained, as they will eliminate having to drain and refill the entire system.
- 9) Strainer (recommended) – Install a Y Strainer, or other suitable strainer, to prevent any system debris from entering the boiler and fouling the water passages. Note that some strainers have a significant pressure drop, which may impact the ability of the boiler pump to obtain the required flow. See section B for additional information.

10) Drain Valve (required) – Install the drain valve supplied as shown in Figure 9.9.

11) Low Water Cut-off (may be required by local jurisdiction) – Protection of this boiler against low water and/or inadequate flow is provided by the UL353 certified flow switch built into the boiler. This is a water tube boiler and this flow switch is therefore the only effective way to provide such protection. Section HG614(c) of the 2013 ASME boiler and Pressure Vessel Code recognizes the use of a listed flow switch in lieu of a low water cut-off on water tube boilers.

In the event that a local jurisdiction insists upon the installation of a low water cut-off with this boiler, a low water cut-off kit is available that plugs into the low voltage circuit board (see Part X). Install the low water cut-off in the supply piping at the point prescribed the local jurisdiction (generally at a point above the boiler).

If a probe type low water cut-off is used, be certain that it is located at a point in the piping from which air can escape to an automatic air vent. Generally, this means that there should be no down-turns in the piping between the low water cut-off and the point where the automatic air vent is installed. Failure to do this may result in nuisance boiler shut-downs due to small amounts of air trapped around the probe.

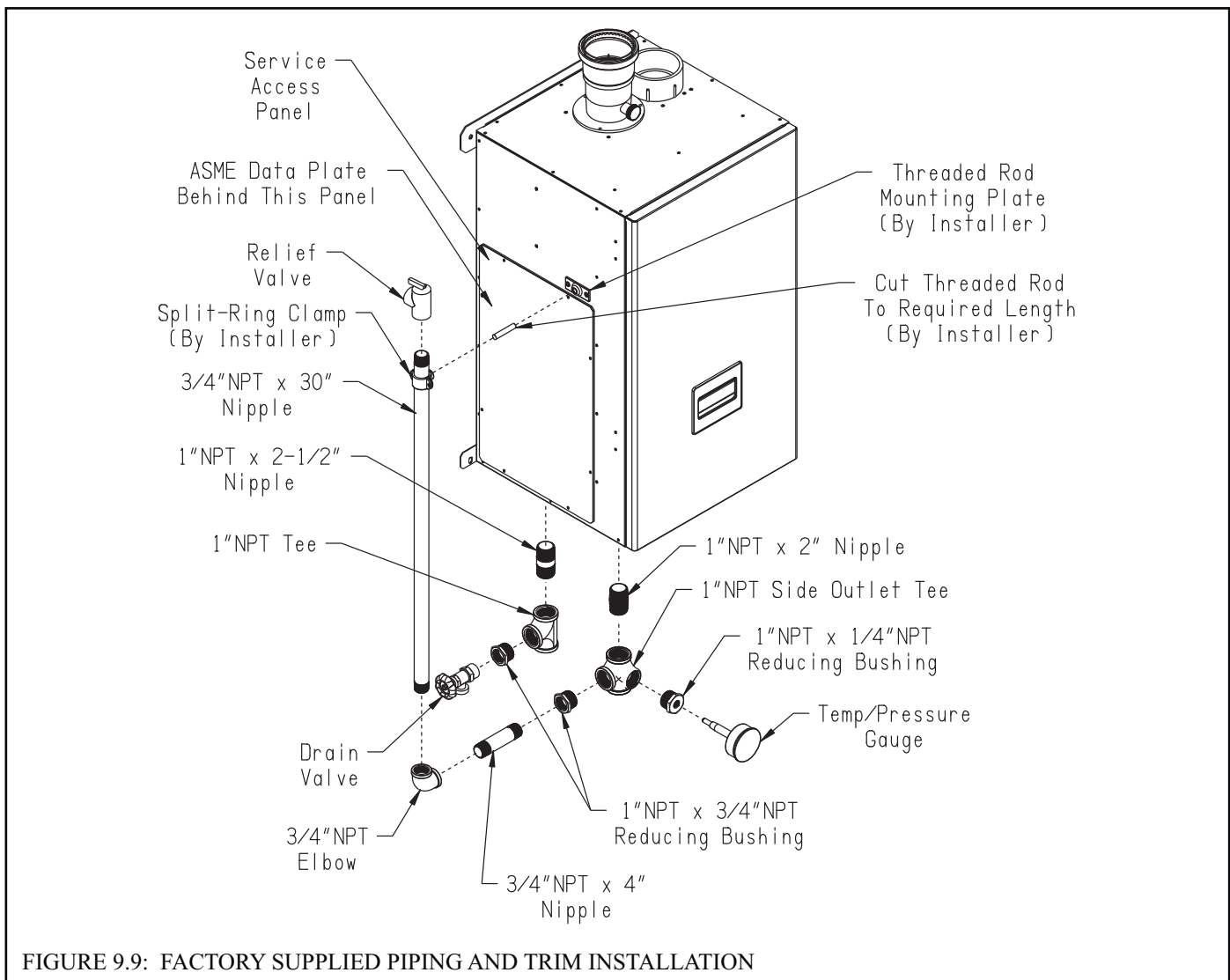



## D. Piping for Special Situations

1) Systems containing oxygen - Many hydronic systems contain enough dissolved oxygen to cause severe corrosion damage to a this boiler. Some examples include:

- Radiant systems that employ tubing without an oxygen barrier.
- Systems with routine additions of fresh water.
- Systems which are open to the atmosphere.

If the boiler is to be used in such a system, it must be separated from the oxygenated water being heated with a heat exchanger as shown in Figure 9.10. Consult the heat exchanger manufacturer for proper heat exchanger sizing as well as flow and temperature requirements. All components on the oxygenated side of the heat exchanger, such as the pump and expansion tank, must be designed for use in oxygenated water.

2) Piping with a Chiller - If the boiler is used in conjunction with a chiller, pipe the boiler and chiller in parallel. Use isolation valves to prevent chilled water from entering the boiler.

3) Air Handlers - Where the boiler is connected to air handlers through which refrigerated air passes, use flow control valves in the boiler piping or other automatic means to prevent gravity circulation during the cooling cycle.

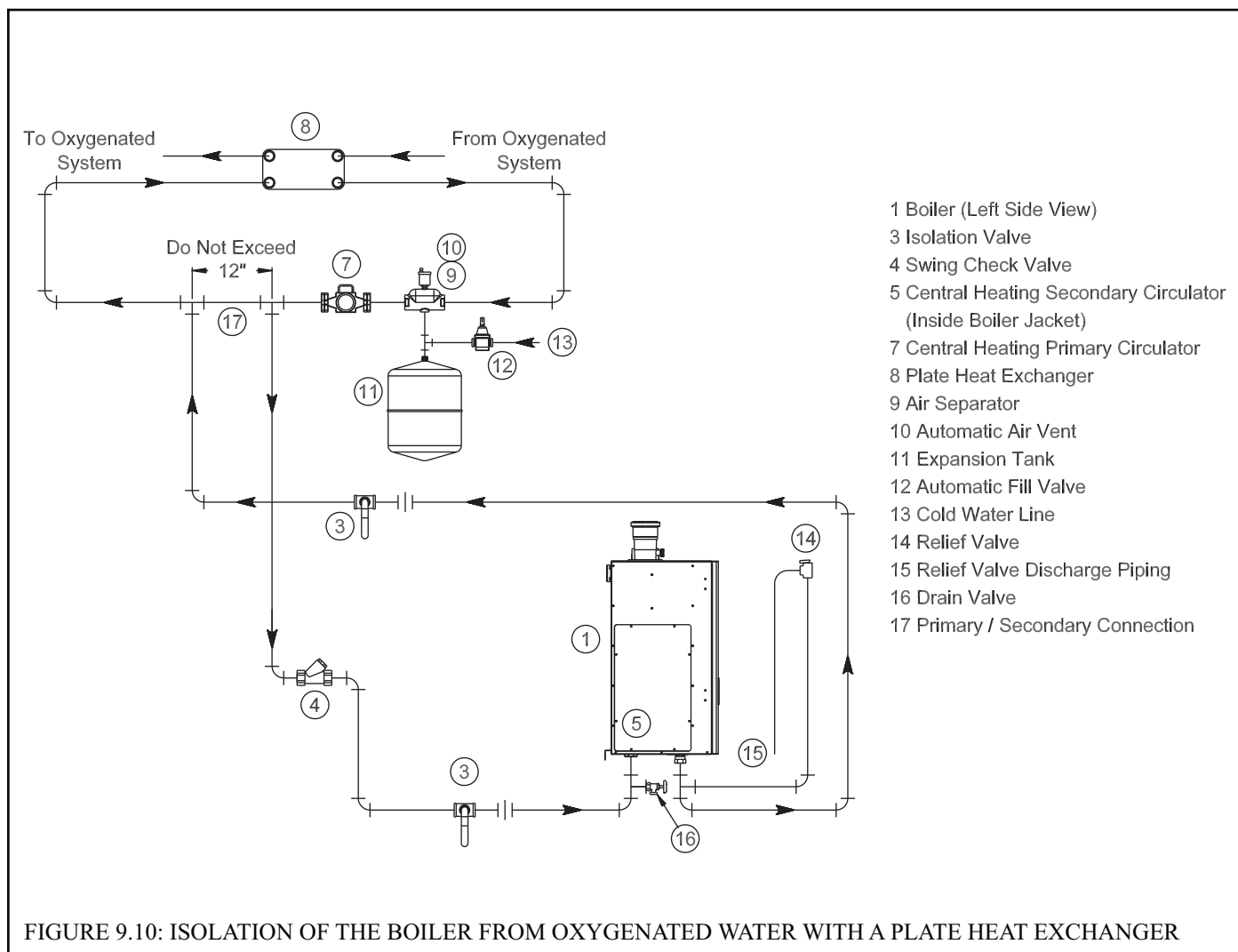

## X Wiring



### DANGER

**Positively assure all electrical connections are unpowered before attempting installation or service of electrical components or connections of the boiler or building. Lock out all electrical boxes with padlock once power is turned off.**



### WARNING

- **All wiring and grounding must be done in accordance with the authority having jurisdiction or, in the absence of such requirements, with the National Electrical Code (NFPA 70). In Canada, all wiring and grounding must be done in accordance with the Canadian Electrical Code, Part 1 (CSA C22.1 - latest edition).**
- **Failure to properly wire electrical connections to the boiler may result in serious physical harm.**
- **Electrical power may be supplied from more than one circuit. Make sure all power is off before attempting any electrical work.**
- **Each boiler must be protected with a properly sized over-current device.**
- **Never jump out or make inoperative any safety or operating controls.**
- **The wiring diagrams contained in this manual are for reference purposes only. Each boiler is shipped with a wiring diagram attached to the front door. Refer to this diagram and the wiring diagram of any controls used with the boiler. Read, understand and follow all wiring instructions supplied with the controls.**

### NOTICE

**This boiler is equipped with a listed high water temperature limit function. This limit provides boiler shutdown in the event the boiler water temperature exceeds the set point of the limit control. Certain Local Codes require an additional water temperature limit. If necessary, install an additional water temperature limit such as a Honeywell L4006 Aquastat. Wire as indicated in Figure 10.3.**

Figure 10.1 shows the location of both the high voltage and low voltage printed circuit boards with terminal strips for field wiring. To access the PCB's, first remove the sheet metal screw used to secure the wiring compartment cover and then lift out the cover.

- 1) Line Voltage (120 VAC) Field Connections – See Figure 10.2 for line voltage connections. Provide a dedicated circuit for the boiler of 15A or greater. A service switch is recommended and is required by many local codes. Locate this switch in accordance with local codes or, in the absence of any, in a location where it can be safely accessed in an emergency involving the boiler. All 120VAC connections to the boiler itself are made on the terminal strip on the high voltage PCB located on the left side of the wiring compartment. From top to bottom, the connections on the terminal strip are:

- 120VAC Hot
- 120VAC Neutral
- Ground
- System Pump Hot
- System Pump Neutral
- DHW Pump Hot
- DHW Pump Neutral

The use of the pump outputs are as follows:

- a) System Pump - Pumps water through the radiation. This pump is hydraulically separated from the boiler pump, either by closely spaced tees, or by a hydraulic separator. The system pump is always on when the system is responding to a call for CH. Depending on the DHW configuration, it may also be on during a call for DHW.
- b) DHW Pump (“IWH Circulator”) - Pumps water directly through the indirect water heater.

Maximum combined current draw for all circulators is 6.3 FLA. See Section XII of this manual for information on setting up the pump operation.

2) Low Voltage Connections – Low voltage field connections on the low voltage PCB are shown in Figure 10.3 and are listed from top to bottom:

- Heat T’Stat - 24VAC heating thermostat (R - 24V “Hot”)
- Heat T’Stat - 24VAC heating thermostat (W - Energized or Call for Heat)
- Heat T’Stat - 24VAC heating thermostat (C - 24V Common)
- DHW Stat - 24VAC domestic hot water thermostat (1)
- DHW Stat - 24VAC domestic hot water thermostat (2)
- External Limit - Field supplied low voltage safety limit contacts (1)
- External Limit - Field supplied low voltage safety limit contacts (2)
- Alarm Contact (1)
- Alarm Contact (2)
- EnviraCOM Device (D)
- EnviraCOM Device (R)
- EnviraCOM Device (C)

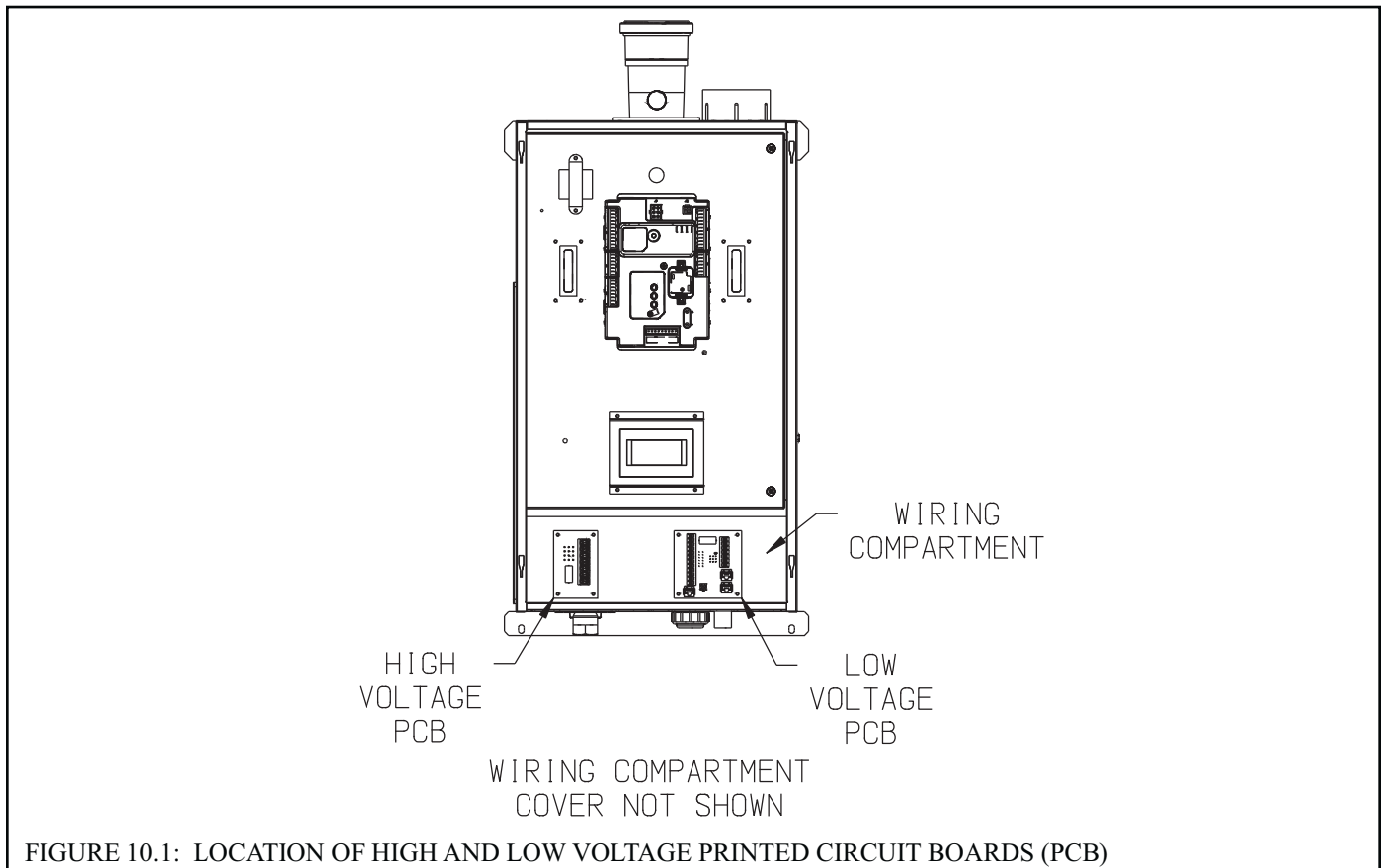
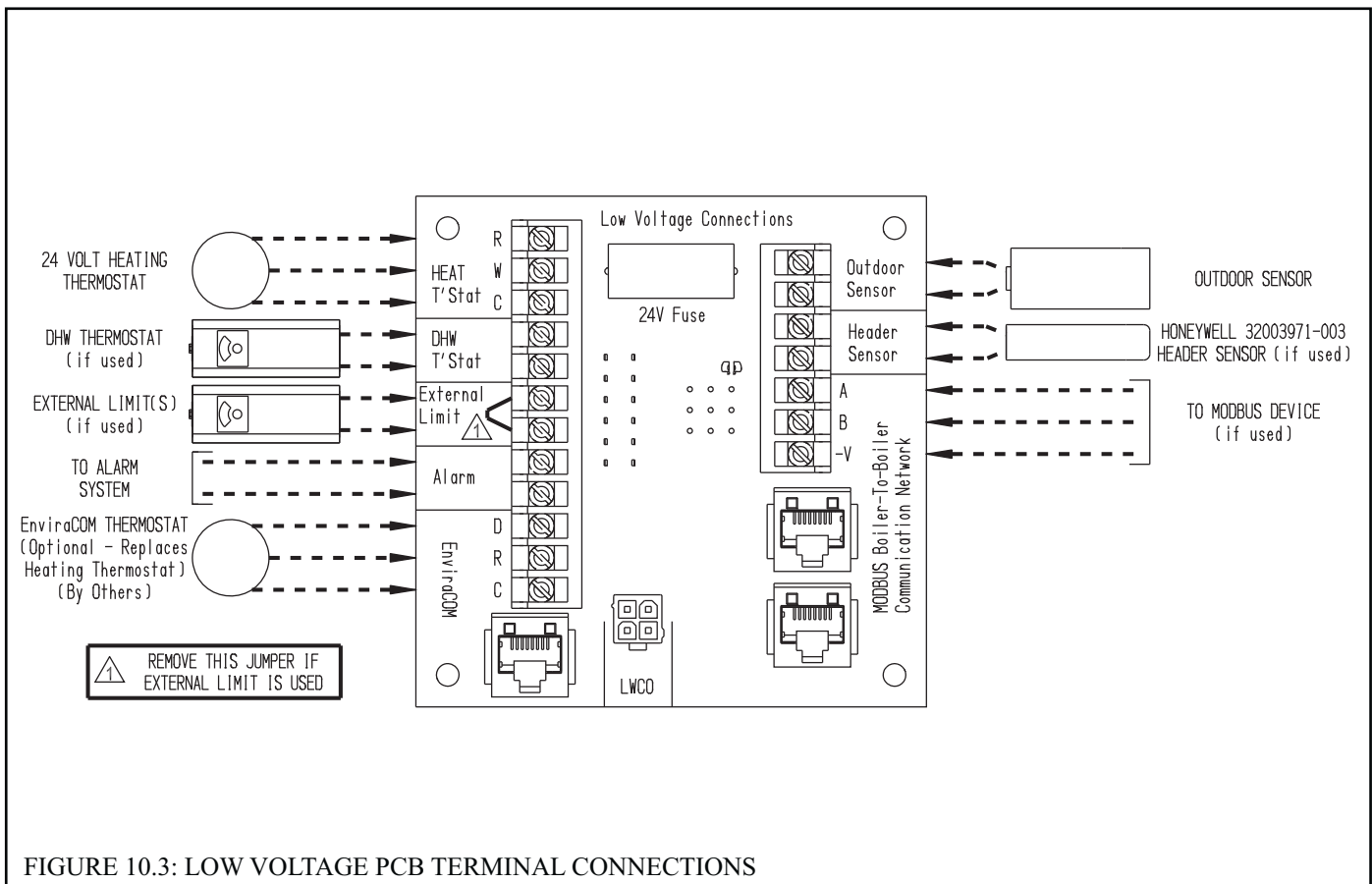
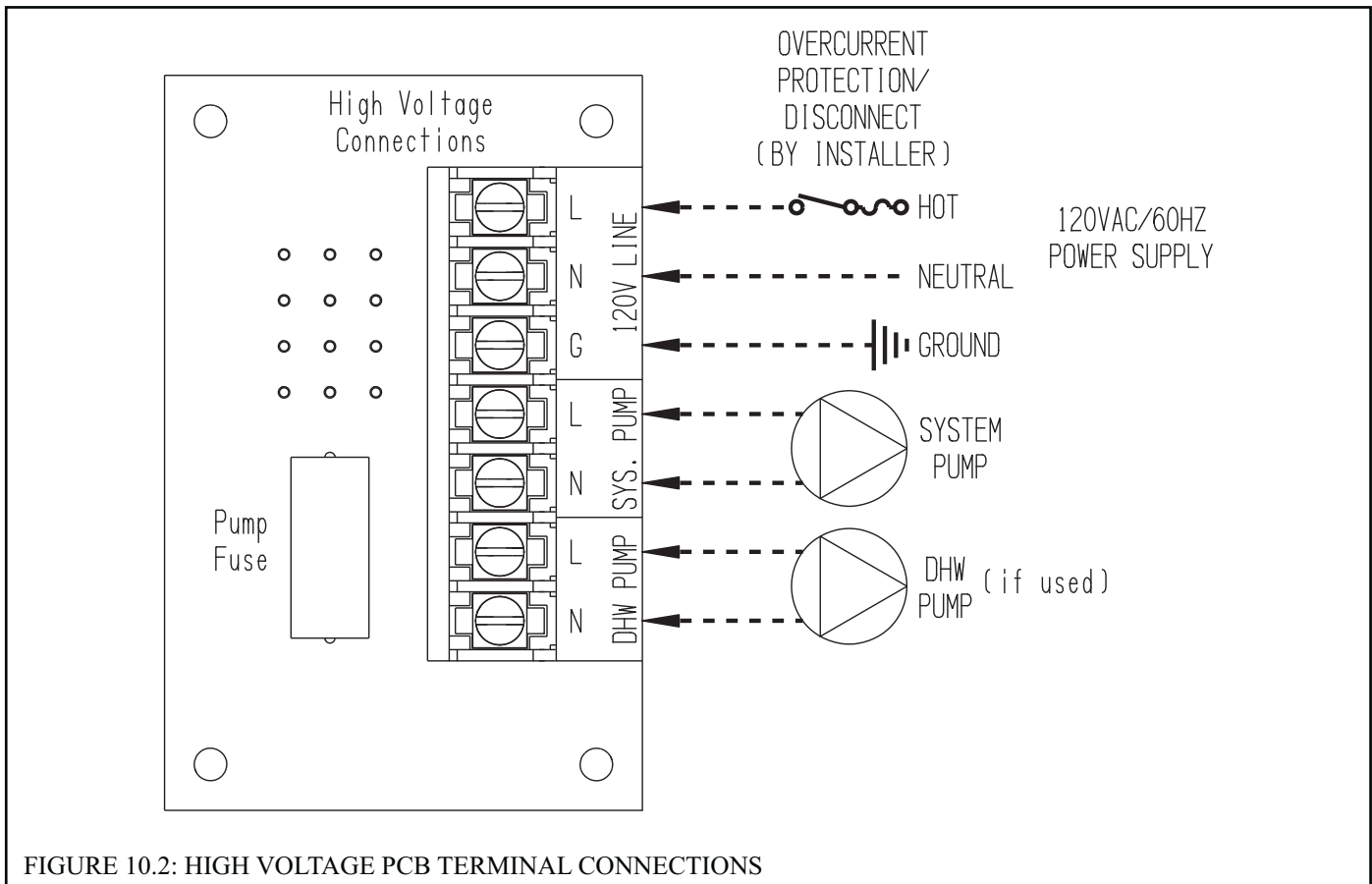

FIGURE 10.1: LOCATION OF HIGH AND LOW VOLTAGE PRINTED CIRCUIT BOARDS (PCB)



- Outdoor Sensor - Tasseron TSA00AA Outdoor Temperature Sensor (1)
- Outdoor Sensor - Tasseron TSA00AA Outdoor Temperature Sensor (2)
- Header Sensor - Optional Honeywell 32003971-003 Sensor (1)
- Header Sensor - Optional Honeywell 32003971-003 Sensor (2)
- MODBUS - (A)
- MODBUS - (B)
- MODBUS - (-V)

With the exception of the alarm contacts, external power must not be applied to any of the low voltage terminals - doing so may damage the boiler control. Also note the following:

- External Limit - The external limit terminals are intended for use with a field supplied safety device, such as a manual reset high limit. When an external limit is used, the jumper between these two terminals must be removed. Failure to remove this jumper will render the external safety devices ineffective.
- Alarm Contacts - These contacts close when the boiler enters a “hard” lockout (lockout requiring manual reset). They may be used as an input to a building alarm system. Contact rating is 24VAC, 0.63FLA. Do not use for line voltage applications.
- EnviraCOM - Used to connect EnviraCOM thermostat or other EnviraCOM device approved by the boiler manufacturer for use with this boiler. A Honeywell EnviraCOM connection is also located as labeled on the boiler control itself.
- Outdoor Sensor - Use only the Tasseron TSA00AA outdoor sensor supplied with the boiler. When this sensor is connected and enabled, the boiler will adjust the target supply water temperature downwards as the outdoor air temperature increases. This sensor should be located on the outside of the structure in an area where it will sense the average air temperature around the house. Avoid placing this sensor in areas where it may be covered with ice or snow. In general, locations where the sensor will pick up direct radiation from the sun should also be avoided. Avoid placing the sensor near potential sources of electrical noise such as transformers, power lines, and fluorescent lighting. Wire the sensor to the boiler using 22 gauge or larger wire. As with the sensor itself, the sensor wiring should be routed away from sources of electrical noise. Where it is impossible to avoid such noise sources, wire the sensor using a 2 conductor, UL Type CM, AWM Style 2092 shielded cable. Connect one end of the shielding on this cable to ground. See Section XII of this manual for information on enabling the outdoor reset sensor.
- Header Sensor - When this sensor is installed and enabled, the boiler will attempt to maintain the target water temperature in the header rather than in the supply. Where the system flow rate varies widely, the use of a header sensor allows the temperature of the water being sent to the radiation to be more accurately controlled. Use only the Honeywell 32003971-003 sensor listed above. Locate this sensor immediately downstream of the second primary-secondary Tee (Figure 10.4). Installation of this sensor in a well, as opposed to on the surface of the header, is highly recommended. The sensor wiring should be routed away from sources of electrical noise. Where it is impossible to avoid such noise sources, wire the sensor using a 2 conductor, UL Type CM, AWM Style 2092, 300Volt 60°C shielded cable. Connect one end of the shielding on this cable to ground. See Section XII for information on enabling the header sensor.
- MODBUS - Boiler-To-Boiler communication network is used for multiple boiler (“Lead-Lag”) installations. See the multiple boiler installation supplement for additional information.



## CAUTION

- **When making low voltage connections, make sure that no external power source is present in the thermostat or limit circuits. If such a power source is present, it could destroy the boiler’s control. One example of an external power source that could be inadvertently connected to the low voltage connections is a transformer in the old thermostat wiring.**
- **Do not attempt to use EnviraCOM connections for any purpose not explicitly permitted by the boiler manufacturer. Attempting to do so may result in unreliable operation and/or damage to controls**

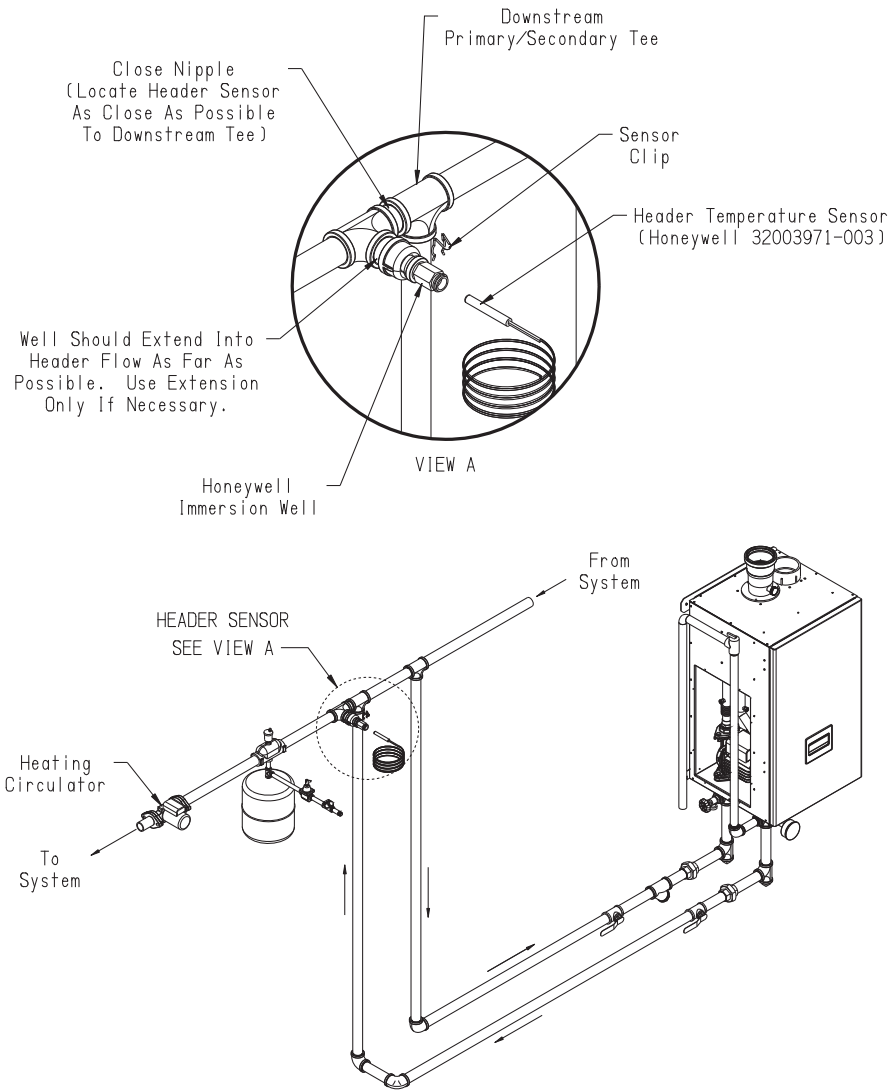

FIGURE 10.4: PROPER INSTALLATION OF HEADER SENSOR

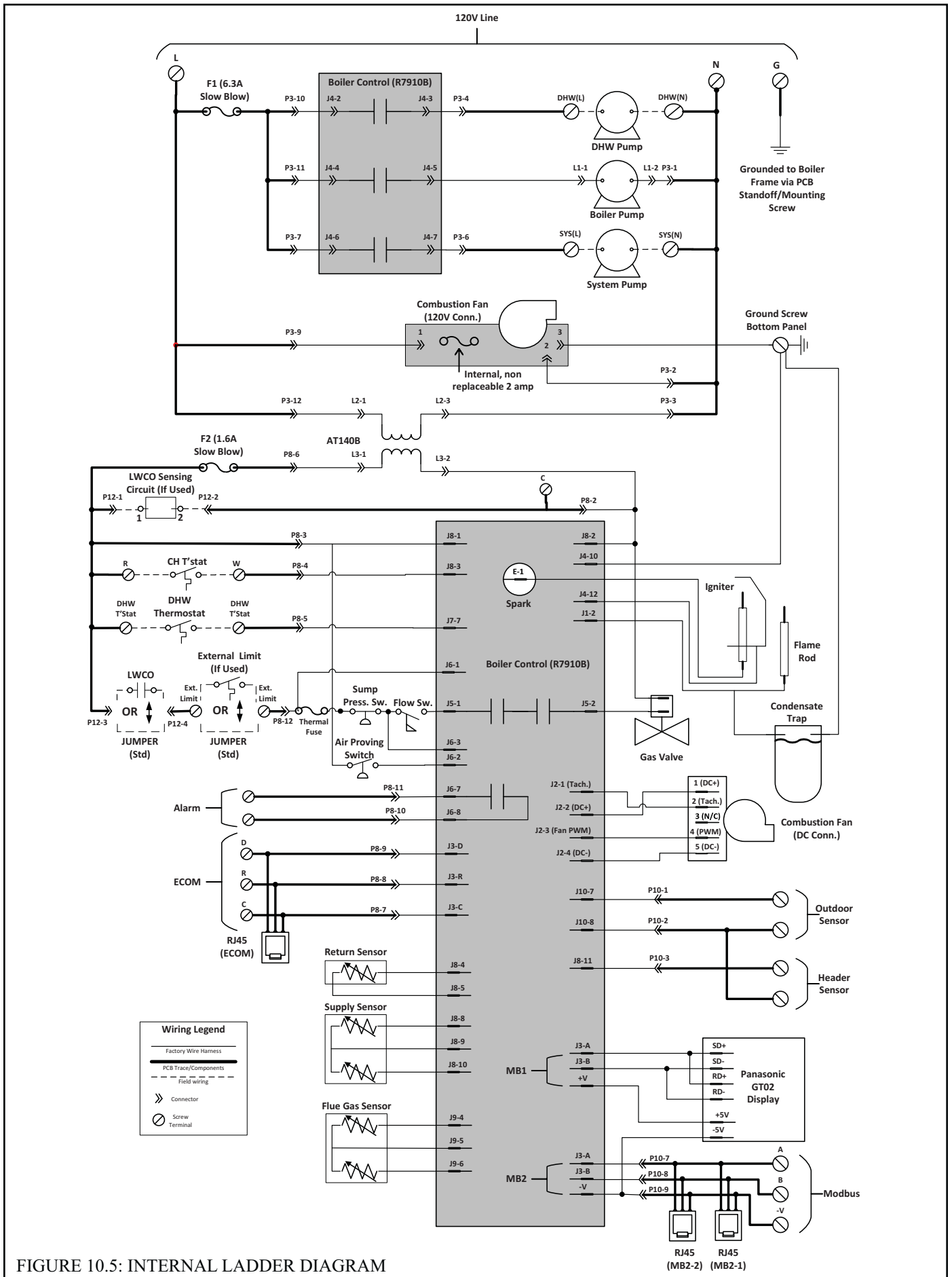

FIGURE 10.5: INTERNAL LADDER DIAGRAM







## XI Start-up and Checkout

### WARNING

Completely read, understand and follow all instructions in this manual before attempting start-up.

### NOTICE

**Safe lighting and other performance criteria were met with the gas train assembly provided on the boiler when the boiler underwent the test specified in Z21.13.**

Use the following procedure for initial start-up of the boiler:

- 1) Verify that the venting, water piping, gas piping and electrical system are installed properly.
- 2) Confirm all electrical, water and gas supplies are turned off at the source and that vent is clear of obstructions.
- 3) Confirm that all manual shut-off gas valves between the boiler and gas source are closed.
- 4) If not already done, flush the system to remove sediment, flux, and traces of boiler additives.
- 5) Fill the boiler and hydronic system with water meeting the following requirements below (also see the note on the next page):
  - pH between 6.5 and 9.5
  - Hardness less than 7 grains/gallon
  - Chlorides less than 200ppm
  - Pressurize the system to at least 12 psi at the boiler

### WARNING

**Scald Hazard. The maximum operating pressure of this boiler is 30 psig or 50 psig depending on the model and relief valve selected. Never exceed these pressures.**

- 6) Bleed air from the heat exchanger using the manual air vent in the top left side of the heat exchanger (Figure 11.1). To do this install a piece of ¼" ID clear tubing over the hose barb and route the tubing to a location where water will not damage controls or nearby construction. Turn vent counter clockwise and allow heat exchanger to vent until a steady stream of water is observed. Close vent and remove hose.
- 7) Check all gas piping for leaks and purge piping sections that are filled with air. Refer to the *National Fuel Gas Code* for additional information on testing and purging gas lines.

### DANGER

- **Do not use matches, candles, open flames or other ignition source to check for leaks.**
- **Make sure that the area around the boiler is clear and free from combustible materials, gasoline and other flammable vapors and liquids.**

- 8) Confirm vent system is complete and free of obstructions before attempting to fire boiler.
- 9) Inspect all wiring for loose, uninsulated or miswired connections.



## DANGER

**Asphyxiation Hazard. Failure to properly convert this boiler for use on lp gas can cause unreliable operation at elevated carbon monoxide (CO) levels, resulting in personal injury or death.**

## NOTICE

To minimize the risk of premature heat exchanger failure, observe the following water chemistry requirements:

- 1) Minimize the introduction of make-up water, dissolved oxygen, and contaminants into the boiler by following the installation guidelines shown in the Water Quality and Boiler Water Additives Note on Page 64.
- 2) Make sure the system is filled with water meeting the following criteria:
  - pH between 6.5 and 9.5 (for systems containing aluminum components, between 6.5 and 8.5)
  - Chloride level less than 200PPM. If fill water is drawn from a system containing a water softener, test a sample of the fill water to confirm that this criteria is met.
  - Hardness less than 7 grains/gallon.
- 3) Avoid the use of petroleum based boiler additives. These can attack seals in both the boiler and system.
- 4) If freeze protection is required, use the following or its equivalent:
  - Fernox Alphi -11 (inhibited Propylene Glycol) available from Alent plc Consumer Products Division, 4100 6th Avenue, Altoona PA. (972) 547 6002 (fernox\_usa@alent.com).

Refer to the antifreeze manufacturer's instructions for required dosage. In general these products are a blend of glycol (for freeze protection) and inhibitors (to protect the glycol from attacking metallic system components). Do not add any more antifreeze than is necessary to protect the system from freeze damage. Many of these products require annual testing of the system water to ensure that the inhibitors are still active; consult the manufacturer's instructions for maintenance requirements. Allowance must be made for the additional expansion of the glycol solution.

- 5) For system cleaning, use the following or its equivalent:
  - Fernox Cleaner F3 available from Alent plc Consumer Products Division, 4100 6th Avenue, Altoona PA. (972) 547 6002 (fernox\_usa@alent.com).

Refer to the instructions supplied with the cleaner for proper dosage and use.



## WARNING

**Poison Hazard. Use only inhibited propylene glycol solutions specifically formulated for hydronic systems. Do not use ethylene glycol, which is toxic and can attack gaskets and seals used in hydronic systems. Use of ethylene glycol could result in property damage, personal injury or death.**

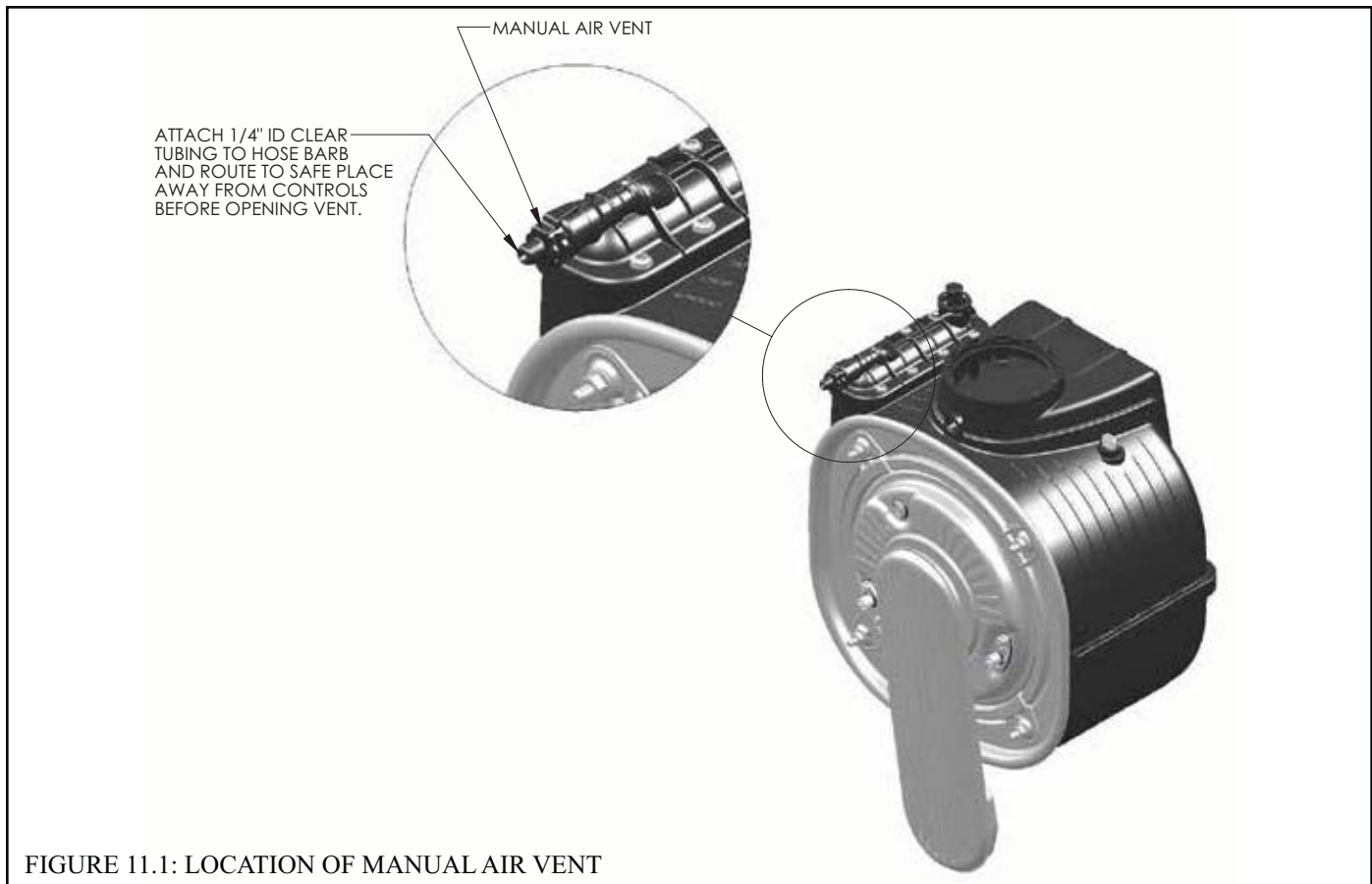

FIGURE 11.1: LOCATION OF MANUAL AIR VENT

- 10) If the boiler is to be converted to propane (LP gas) or used at altitude above 2000ft, start-up and adjust throttle as described in Appendix A.
- 11) Start the boiler using the lighting instructions on page 90. With the boiler powered up, and with no call for heat, the display should look like Figure 11.2a. Once a call for heat is present, it will look like Figure 11.2b.
- 12) The boiler should attempt to fire approximately 30 seconds after a call for heat appears. With the upper front cover removed from the boiler, this try for ignition will appear as an audible spark (lasting approximately 4 seconds) and an audible click from the gas valve. Upon initial start-up, the gas train will be filled with air. Even if the gas line has been completely purged of air, it may take several tries for ignition before a flame is established. If the boiler does not light after four tries for ignition, it will enter a “soft lockout” and will wait for one hour before attempting another ignition sequence. This soft lockout can be reset by interrupting power to the boiler for a few seconds. Once a flame has been established for the first time, subsequent calls for burner operation should result in a flame on the first try.
- 13) If there is a problem that appears before the first try for ignition, or if the boiler fails to light after five tries for ignition, the flashing “Active Fault” button will appear on the Home screen (Figure 11.2c). Touching this button will take the user to the Diagnostics menu where the cause of the problem can usually be found by pressing the flashing button on each successive screen. For more information, see Section XIV of this manual.
- 14) Inspect the flame visible through the window. On high fire the flame should be stable and mostly blue (Fig.11.3). No yellow tipping should be present; however, intermittent flecks of yellow and orange in the flame are normal.
- 15) Check the inlet gas pressure. Verify that the inlet gas pressure is between the upper and lower limits shown on the rating plate with all gas appliances on and off.



FIGURE 11.2a: HOME SCREEN AT POWER-UP (No Call for Heat)



FIGURE 11.2b: HOME SCREEN ON HEAT DEMAND

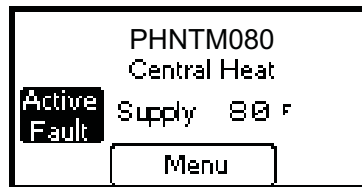
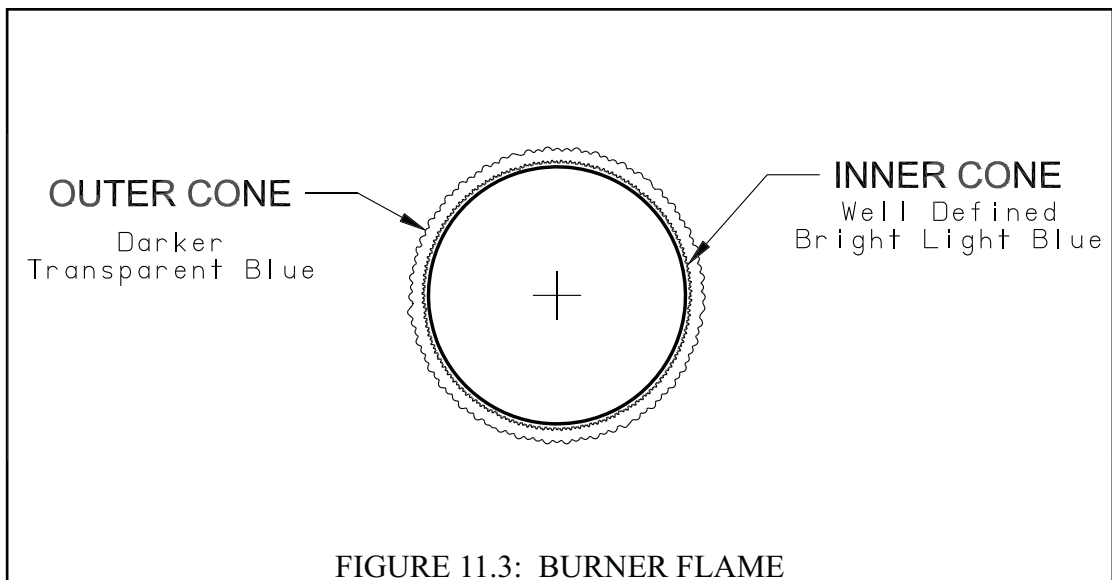

FIGURE 11.2c: HOME SCREEN WITH ACTIVE FAULT



**! WARNING**

**Asphyxiation Hazard.** Each boiler is tested at the factory and adjustments to the air-fuel mixture are normally not necessary when operating on natural gas at sea level. Consult the factory before attempting to make any such adjustments. Improper gas valve or mixture adjustments could result in property damage, personal injury or loss of life due to carbon monoxide (CO) poisoning.

**! WARNING**

**Asphyxiation Hazard.** The outlet pressure for the gas valve has been factory set and requires no field adjustment. This setting is satisfactory for both natural gas and propane. Attempting to adjust the outlet pressure may result in damage to the gas valve and cause property damage, personal injury or loss of life due to carbon monoxide (CO) poisoning.

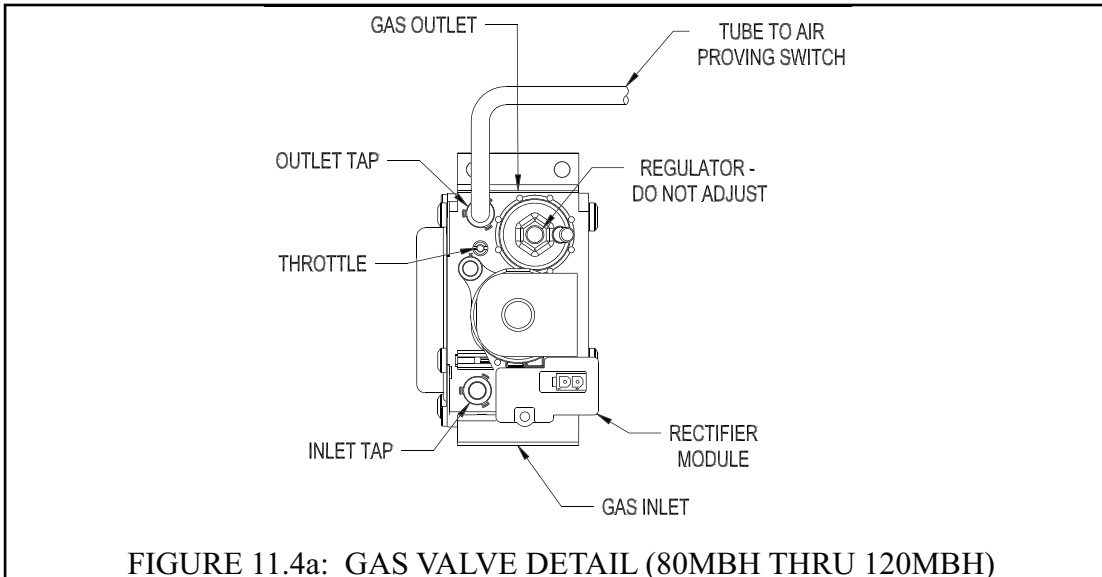

FIGURE 11.4a: GAS VALVE DETAIL (80MBH THRU 120MBH)

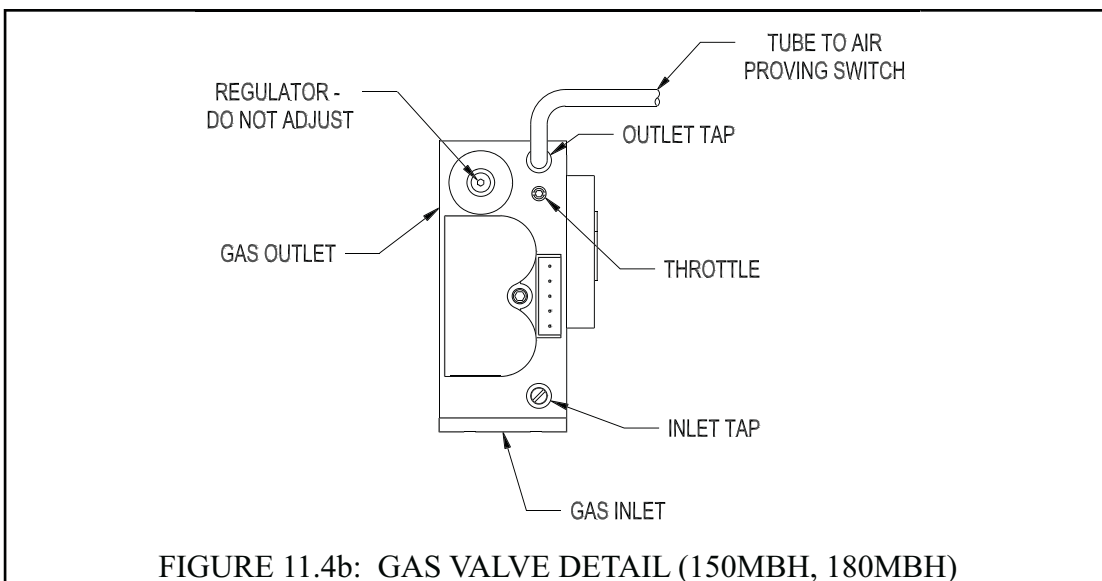

FIGURE 11.4b: GAS VALVE DETAIL (150MBH, 180MBH)

- 16) Perform a combustion test. Boilers are equipped with a screw cap in the vent adapter. Be sure to replace this cap when combustion testing is complete. Check CO<sub>2</sub> (or O<sub>2</sub>) and CO at both high and low fire. The boiler may be temporarily locked into high or low fire as follows:
- From the Home Screen, press “MENU” to enter the main menu.
  - Press “SETTINGS”.
  - If prompted for a password, use the “+1” key to raise the password to “005” and press SUBMIT, then NEXT (if you accidentally scroll past 005, press EXIT to return to the main menu and start over).
  - Review the Warning and press ACCEPT to continue to the Settings Menu.
  - At the Settings Menu select “MANUAL INPUT”.
  - Press HIGH FIRE HOLD or LOW FIRE HOLD as appropriate.

To return the boiler to automatic modulation, press AUTO FIRE. Note: If the Auto Fire button is not pressed, boiler will remain in manual fire until the display returns to the Home Screen. This happens automatically if the screen is not touched for a period of time, which varies depending on which screen is open. From the manual input screen, it takes 12min:45s.

At both high and low fire, CO readings should be less than 200 PPM air free. Typical CO<sub>2</sub> and O<sub>2</sub> readings are shown in Table 11.5. Final readings should be taken with all doors and covers in place.

- 17) Perform a check of the ignition safety shut-off device. With the burner firing, carefully unplug the orange flame rod wire at the flame rod using a pair of insulated pliers (Figure 13.1). The burner should shut off immediately.
- 18) Test any external limits or other controls in accordance with the manufacturer’s instructions.
- 19) Refer to the Operation Section to set-up the control for the system in which the boiler is installed. Some common set-up tasks include:
- Setting the CH and DHW temperature set-points (as shipped, both setpoints are set to 180°F).
  - Selecting the type of indirect water heater (if any) and location of DHW pumps.
  - Defining the system pump operation.
- 20) Adjust the heating and indirect water heater thermostats to their final set points.

Model	Fuel	%CO <sub>2</sub>	%O <sub>2</sub>	Max CO Air Free (ppm)
80MBH	Natural Gas	9.0	5.1	200
80MBH	Propane	10.2	5.4	200
100MBH	Natural Gas	9.0	5.1	200
100MBH	Propane	10.2	5.4	200
120MBH	Natural Gas	9.0	5.1	200
120MBH	Propane	10.2	5.4	200
150MBH	Natural Gas	9.0	5.1	200
150MBH	Propane	10.2	5.4	200
180MBH	Natural Gas	9.0	5.1	200
180MBH	Propane	10.2	5.4	200

TABLE 11.5: TYPICAL SEA LEVEL COMBUSTION READINGS

### NOTICE

**This boiler has a limited warranty, a copy of which is included with this boiler. It is the responsibility of the installing contractor to see that all controls are correctly installed and are operating properly when the installation is complete.**

## Lighting and Operating Instructions

### FOR YOUR SAFETY READ BEFORE OPERATING/POUR VOTRE SECURITE LISEZ AVANT DE METTRE EN MARCHÉ

**WARNING:** If you do not follow these instructions exactly, a fire or explosion may result causing property damage, personal injury or loss of life.

**AVERTISSEMENT:** Quiconque ne respecte pas à la lettre les instructions dans la présente notice risque de déclencher un incendie ou une explosion entraînant des dommages, des blessures ou la mort.

- A. This appliance does not have a pilot. It is equipped with an ignition device which automatically lights the burner. Do not try to light the burner by hand.
- B. BEFORE OPERATING smell all around the appliance area for gas. Be sure to smell next to the floor because some gas is heavier than air and will settle on the floor.

#### WHAT TO DO IF YOU SMELL GAS:

- Do not try to light any appliance.
  - Do not touch any electric switch; do not use any phone in your building.
  - Immediately call your gas supplier from a neighbor's phone. Follow the gas supplier's instructions.
  - If you cannot reach your gas supplier, call the fire department.
- C. Use only your hand to turn the gas control knob. Never use tools. If the knob will not turn by hand, don't try to repair it, call a qualified service technician. Force or attempted repair may result in a fire or explosion.
- D. Do not use this appliance if any part has been under water. Immediately call a qualified service technician to inspect the appliance and to replace any part of the control system and any gas control which has been under water.

- A. Cet appareil ne comporte pas de veilleuse. Il est muni d'un dispositif d'allumage qui allume automatiquement le brûleur. Ne tentez pas d'allumer le brûleur manuellement.
- B. AVANT DE FAIRE FONCTIONNER, reniflez tout autour de l'appareil pour détecter une odeur de gaz. Reniflez près du plancher, car certains gaz sont plus lourds que l'air et peuvent s'accumuler au niveau du sol.

#### QUE FAIRE SI VOUS SENTEZ UNE ODEUR DE GAZ:

- Ne pas tenter d'allumer d'appareil.
  - Ne touchez à aucun interrupteur ; ne pas vous servir des téléphones se trouvant dans le bâtiment.
  - Appelez immédiatement votre fournisseur de gaz depuis un voisin. Suivez les instructions du fournisseur.
  - Si vous ne pouvez rejoindre le fournisseur, appelez le service des incendies.
- C. Ne poussez ou tournez la manette d'admission du gaz qu'à la main ; ne jamais utiliser d'outil. Si la manette reste coincée, ne pas tenter de la réparer ; appelez un technicien qualifié. Le fait de forcer la manette ou de la réparer peut déclencher une explosion ou un incendie.
- D. N'utilisez pas cet appareil s'il a été plongé dans l'eau, même partiellement. Faites inspecter l'appareil par un technicien qualifié et remplacez toute partie du système de contrôle et toute commande qui ont été plongés dans l'eau.

### OPERATING INSTRUCTIONS/ INSTRUCTIONS DE FONCTIONNEMENT

1. STOP! Read safety information above on this label.
2. Set the thermostat to lowest setting.
3. Turn off all electric power to the appliance.
4. This appliance is equipped with an ignition device which automatically lights the burner. Do not try to light the burner by hand.
5. Turn the external boiler manual gas valve handle clockwise ↻ to close the gas supply.
6. Wait five (5) minutes to clear out any gas. Then smell for gas, including near the floor. If you smell gas, STOP! Follow "B" in the safety information above on this label. If you don't smell gas, go to the next step.
7. Turn the external boiler manual gas valve handle counterclockwise ↺ to open the gas supply.
8. Turn on all electric power to the appliance.
9. Set the thermostat to the desired setting.
10. If the appliance will not operate, follow the instructions "To Turn Off Gas To Appliance" and call your service technician or gas supplier.

OPEN/OUVERT

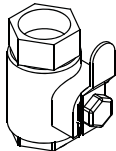

CLOSED/FERMÉ

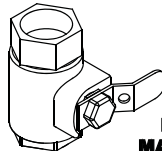

EXTERNAL BOILER  
MANUAL GAS VALVE  
LA CHAUDIÈRE EXTERNE  
MANUELLE DE CLAPET À GAZ

1. ARRÊTEZ ! Lisez les instructions de sécurité sur la portion supérieure cette étiquette.
2. Réglez le thermostat à la température la plus basse.
3. Coupez l'alimentation électrique de l'appareil.
4. Cet appareil est équipé de l' dispositif d'allumage qui automobile allume maticallyle brûleur. Ne tentez pas d'allumer le brûleur manuellement.
5. Tourner la chaudière externe manuelle poignée ↻ en clapet à gaz dans le sens des aiguilles d'une montre pour fermer l'offre de gaz.
6. Attendre cinq (5) minutes pour laisser échapper tout le gaz. Reniflez tout autour de l'appareil, y compris près du plancher, pour détecter une odeur de gaz. Si vous seutez une odeur de gaz, ARRÊTEZ ! Passez à l'étape B des instructions de sécurité sur la portion supérieure de cette étiquette. S'il n'y a pas d'odeur de gaz, passez à l'étape suivante.
7. Tourner la chaudière externe manuelle compteur de poignée ↻ en clapet à gaz ouvrir dans le sens des aiguilles d'une montre le gaz approvisionnement.
8. Mettez l'appareil sous tension.
9. Réglez le thermostat à la température désirée.
10. Si l'appareil ne se met pas en marche, suivez les instructions intitulées « Comment couper l'admission de gaz de l'appareil » et appelez un technicien qualifié ou le fournisseur de gaz.

### TO TURN OFF GAS TO APPLIANCE/ COMMENT COUPER L'ADMISSION DE GAZ DE L'APPAREIL

1. Set the thermostat to lowest setting.
  2. Turn off all electric power to the appliance if service is to be performed.
  3. Turn the external boiler manual gas valve handle clockwise ↻ to close gas supply.
1. Réglez le thermostat à la température la plus basse.
  2. Coupez l'alimentation électrique de l'appareil s'il faut procéder à l'entretien.
  3. Tourner la chaudière externe manuelle poignée ↻ en clapet à gaz dans le sens des aiguilles d'une montre pour fermer l'offre de gaz.



## XII Operation

### A. General Information

This boiler uses the microprocessor based Honeywell R7910B “boiler control” to manage all boiler functions including flame supervision and modulation. Two set point or “target” boiler supply temperatures are stored in the control’s memory; one for space heating (CH) and one for domestic hot water (DHW) production. If an outdoor temperature sensor is connected to the boiler, and enabled, the space heating supply set point will automatically shift downward as the outdoor temperature increases. For more information on this feature see the discussion on boiler water reset below.

The control modulates the boiler input by varying the fan speed. As the fan speed increases, so does the amount of gas drawn into the blower. As a result, a fairly constant air-fuel ratio is maintained across all inputs. The control determines the input needed by looking at both current and recent differences between the supply temperature and the set point temperature. As the supply temperature approaches the set point temperature, the fan will slow down and the input will drop. The minimum input is approximately 1/5 of maximum input.

This boiler control also monitors boiler return and flue temperatures. In addition, all other safety controls are connected into the R7910B. The R7910B uses inputs from all of these controls to either shut down the boiler when an unsafe condition exists or, in some cases, to correct the problem.

Finally, the basic boiler control manages up to three pumps:

- Boiler Loop Pump (built into boiler)
- DHW pump
- System pump

Refer to the Piping Section for the location of these pumps

The touch screen display on this boiler has three basic functions:

- 1) To allow the professional HVAC technician to set-up this boiler so that it will work properly in the system to which it is connected.
- 2) To indicate the current status of the boiler and to provide information that will assist the professional HVAC technician in solving problems with the boiler and/or system.
- 3) To advise the homeowner if there is a problem which requires professional service.

A map of the basic menu structure is shown in Figure 12.0. In order to prevent unauthorized or accidental adjustments, access to menus, which change settings and boiler operation, is password protected. In general, if a menu is not touched for 255 seconds, the display backs up to the previous menu. Once the Home Screen is returned to, the password must be reentered in order to regain access to protected menus (this feature prevents the boiler from being permanently left in operation without password protection).

### B. Configuring the Control

Use the Configuration Menu to provide the boiler with basic information about the type of system to which it is connected. On a new installation configure the boiler first, then go to the Settings Menu to set parameters such as target water temperatures. A map of the Configuration Menu structure is shown in figure 12.1. To configure the boiler:

- 1) From the Home Screen (shown in Figure 12.0) , press “MENU” to enter the Main Menu:
  - a) Press “CONFIGURE”
  - b) When prompted for a password, use the “+1” key to raise the password to “005”. Press SUBMIT, then NEXT (if you accidentally scroll past 005, press EXIT to return to the main menu and start over).
  - c) Review the Warning and press ACCEPT to continue to the Configuration Menu.

## IMPORTANT

This boiler is equipped with a feature that saves energy by reducing the boiler water temperature as the heating load decreases. This feature is equipped with an override which is provided primarily to permit the use of an external energy management system that serves the same function. **THIS OVERRIDE MUST NOT BE USED UNLESS AT LEAST ONE OF THE FOLLOWING CONDITIONS IS TRUE:**

- An external energy management system is installed that reduces the boiler water temperature as the heating load decreases.
- This boiler is not used for any space heating.
- This boiler is part of a modular or multiple boiler system having a total input of 300,000 BTU/hr or greater.

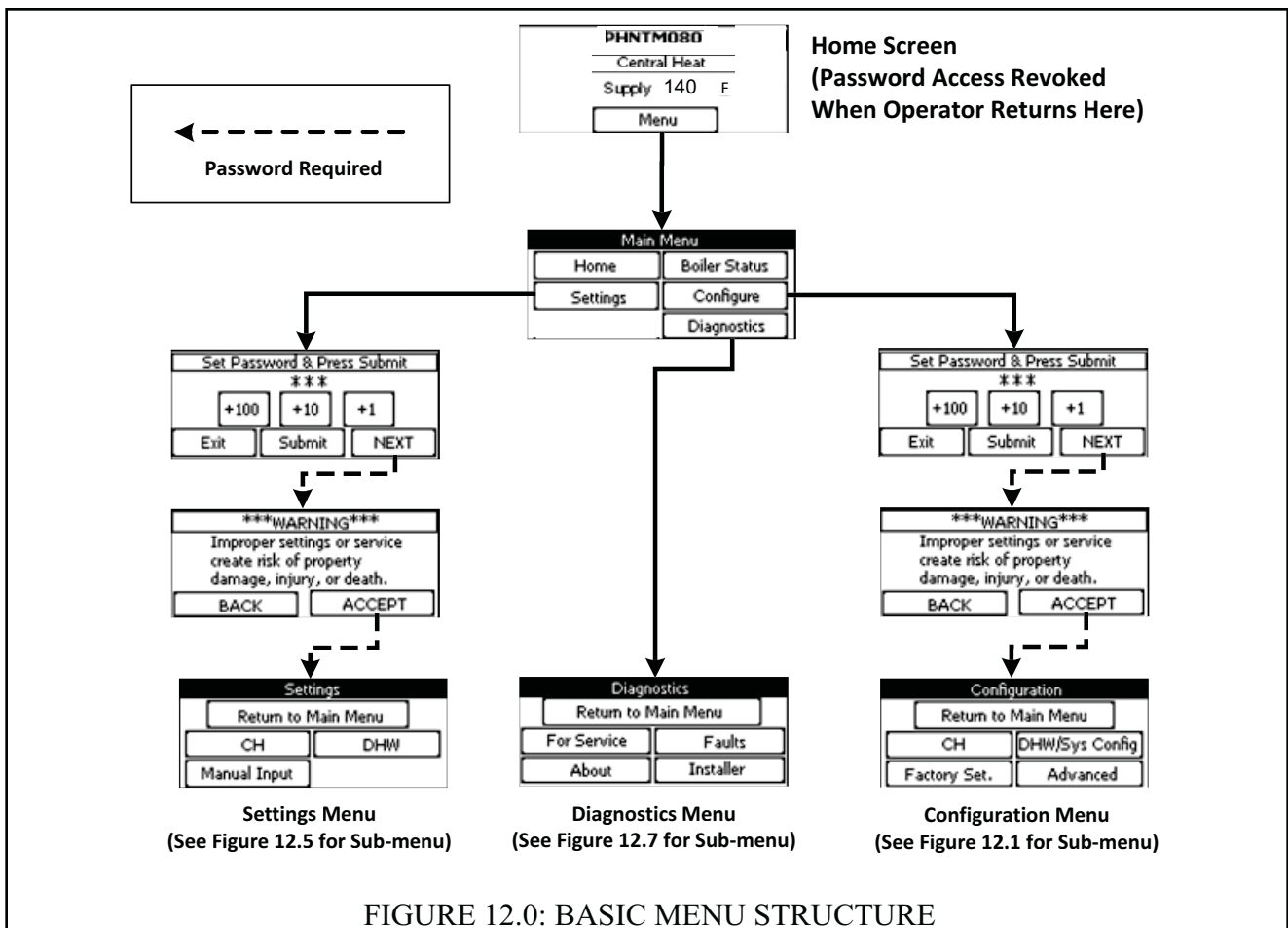

- 2) Press the CH Button to access central heating options. These include:
- a) Setpoint Location - Identifies the sensor that will be used to obtain the target water temperature when the boiler is responding to a call for heat. Choices include:
    - **Supply** (Generally Recommended) - Boiler attempts to obtain the target temperature during a call for heat at the supply sensor built into the boiler.
    - **Header** - Boiler attempts to obtain the target temperature during a call for heat at a Honeywell 32003971-003 sensor (not included) that must be installed in the header as shown in Figure 10.4 of this manual.
  - b) Outdoor Reset - Determines whether or not the outdoor reset function is enabled when the boiler is responding to a call for heat. Choices include:
    - **Outdoor Reset Enabled** - When the boiler is responding to a call for heat, the target water temperature will adjust downward (within certain limits) as the outdoor temperature increases. The graph in Figure 12.6 shows how the target water temperature changes with outdoor temperature. Figure 12.6 shows the default reset curve; the “ends” of this curve can be changed in the Settings Menu.
    - **Outdoor Reset Disabled** - When the boiler is responding to a call for heat, the target water temperature is fixed regardless of what the outdoor temperature is. This fixed setpoint can be changed in the Settings Menu. Outdoor reset function should not be disabled unless at least one of the conditions listed in the “IMPORTANT” box on page 92 is met.
  - c) If outdoor reset is enabled, press the NEXT key to access two more options related to outdoor reset only. Otherwise, press the EXIT button to return the Configuration Menu and skip to Step 3.
  - d) Warm Weather Shutdown (WWSO) - Determines how the boiler responds to a call from the heating thermostat if the outdoor temperature is “warm”.
    - **WWSO Disabled** - The boiler will always respond to a call for heat regardless of the outdoor temperature.
    - **WWSO Enabled** - When the outdoor temperature is above the WWSO Outdoor Temperature setting, the boiler will ignore a call for space heat (CH) from the thermostat.
  - e) ODR Boost - Determines if the boiler automatically increases the target temperature above that determined by the reset curve when it encounters a long call for space heat:
    - **ODR Boost Disabled** (Generally Recommended) - When responding to a call for heat, the target water temperature is determined solely by the outdoor temperature.
    - **ODR Boost Enabled** - When a call for heat first appears, the target water temperature is determined by the reset curve. If the call for heat lasts for 30 minutes, this target temperature is increased by 10°F. The target temperature is then increased in 10°F increments at 30 minute intervals until one of the following happens:
      - \* The call for heat ends.
      - \* The target water temperature is at the top of the reset curve (180°F in the example shown in Figure 12.6)
  - f) Press EXIT to return to the Configuration Menu.
- 3) If this boiler is installed with an indirect water heater which sends a DHW demand directly to the boiler, press the DHW button on the Configuration menu to configure the pump and DHW priority operation. If this is a heat only installation, or if the indirect water heater is controlled by an external zoning panel, skip to Step 4.
- There are three possible DHW configurations. Each of these options is described below and also summarized in Table 12.4. In all three cases, this boiler is intended to accept a DHW demand generated by a thermostat mounted in the indirect water heater, such as a Honeywell L4006A or L4080B, with this device set to the desired potable water temperature. The “DHW target temperature” is therefore the boiler supply temperature required during a call for DHW.

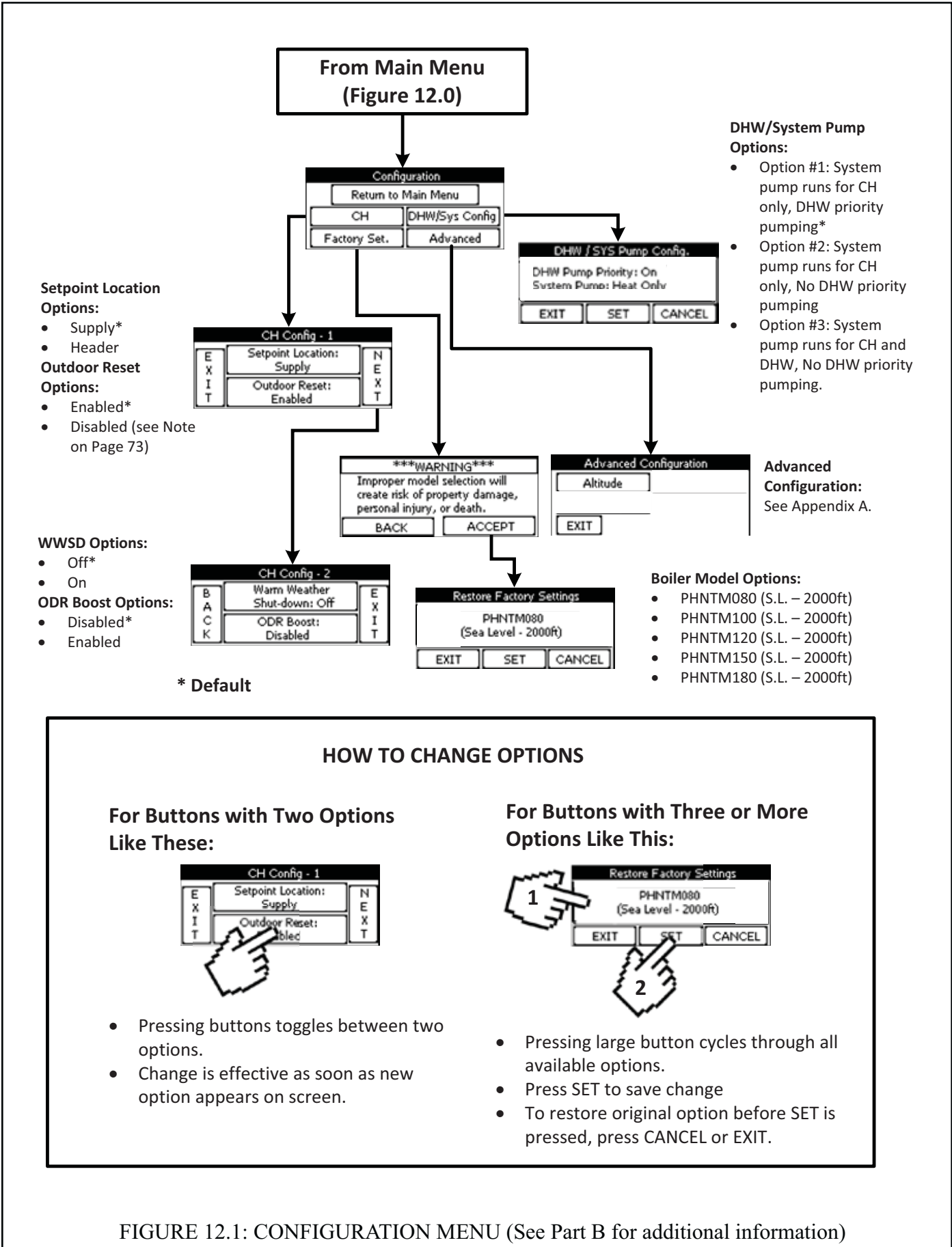

### HOW TO CHANGE OPTIONS

**For Buttons with Two Options Like These:**

- Pressing buttons toggles between two options.
- Change is effective as soon as new option appears on screen.

**For Buttons with Three or More Options Like This:**

- Pressing large button cycles through all available options.
- Press SET to save change
- To restore original option before SET is pressed, press CANCEL or EXIT.



## WARNING

**Burn Hazard. Water temperatures over 125°F can cause personal injury or death due to scalding. Children Disabled, and Elderly are at most risk of being scalded. This boiler is not designed to directly control domestic water temperature.**

- **Use only the thermostat recommended by the indirect water heater manufacture to control the DHW temperature.**
- **Adjust the thermostat set point in accordance with the indirect water heater manufacturer's instructions.**
- **Install scald protection devices as required by the indirect water heater manufacturer or local codes.**
- **Do not attempt to wire a DHW sensor into the boiler control.**

**Option #1 (DEFAULT): System Pump Used for CH Only, DHW Priority Pumping** – An example of this system is shown in Figure 12.2, as well as in Figures 9.3A and 9.3B. When this option is selected, the system operates as follows:

- a) Boiler pump runs whenever there is a demand
- b) DHW pump circulates water through the portion of the system loop where the boiler loop is connected (i.e. the closely spaced tees for the boiler loop).
- c) The system pump is used only to circulate water through the heating (CH) zone/s.
- d) The system pump is not allowed to operate while the boiler is responding to a call for DHW (this strategy permits the entire output of the boiler to be directed to the indirect water heater and in some cases is also needed to protect some types of radiation from excessive temperatures).

**Option #2: System Pump Used for CH Only, No DHW Priority Pumping** – An example of this system is shown in Figure 12.2, as well as in Figures 9.3A and 9.3B. The only difference between Option #2 and Option #1 is that Option #2 permits the system circulator to operate at the same time as the DHW pump when there is a call for both heat and DHW.

**Option #3: System Pump Used for Both CH and DHW, No DHW Priority Pumping** – An example of this system is shown in Figure 12.3, When this option is selected, the system operates as follows:

- a) Boiler pump runs whenever there is a demand.
- b) DHW circulates water only as far as a set of closely spaced tees in the system loop.
- c) The system pump is required to circulate water for either a space heating or DHW demand.
- d) A fourth pump (controlled by an installer supplied relay) is required to circulate water through the radiation.

To change the DHW configuration, press the large button containing the description repeatedly until the desired description is reached. When the selection is changed, this button will flash. When the desired configuration is reached, press SET to select it. When this change is accepted by the control, the button will stop flashing. Press EXIT to Return to the Configuration Menu.



## CAUTION

**Radiant heating systems generally require much lower boiler supply temperatures than those required for a DHW demand. Such systems can be damaged by excessive water temperatures. Do not select Option #2 or Option #3 unless one of the following is true:**

- **The heating system can accept a water temperature greater than or equal to the DHW target temperature.**
- **An external control, such as a thermostatic mixing valve, is used to limit the temperature of the water entering the heating system.**
- **Option #3 is used and there is a field-supplied control system that will force off the CH pump/s during a call for DHW.**

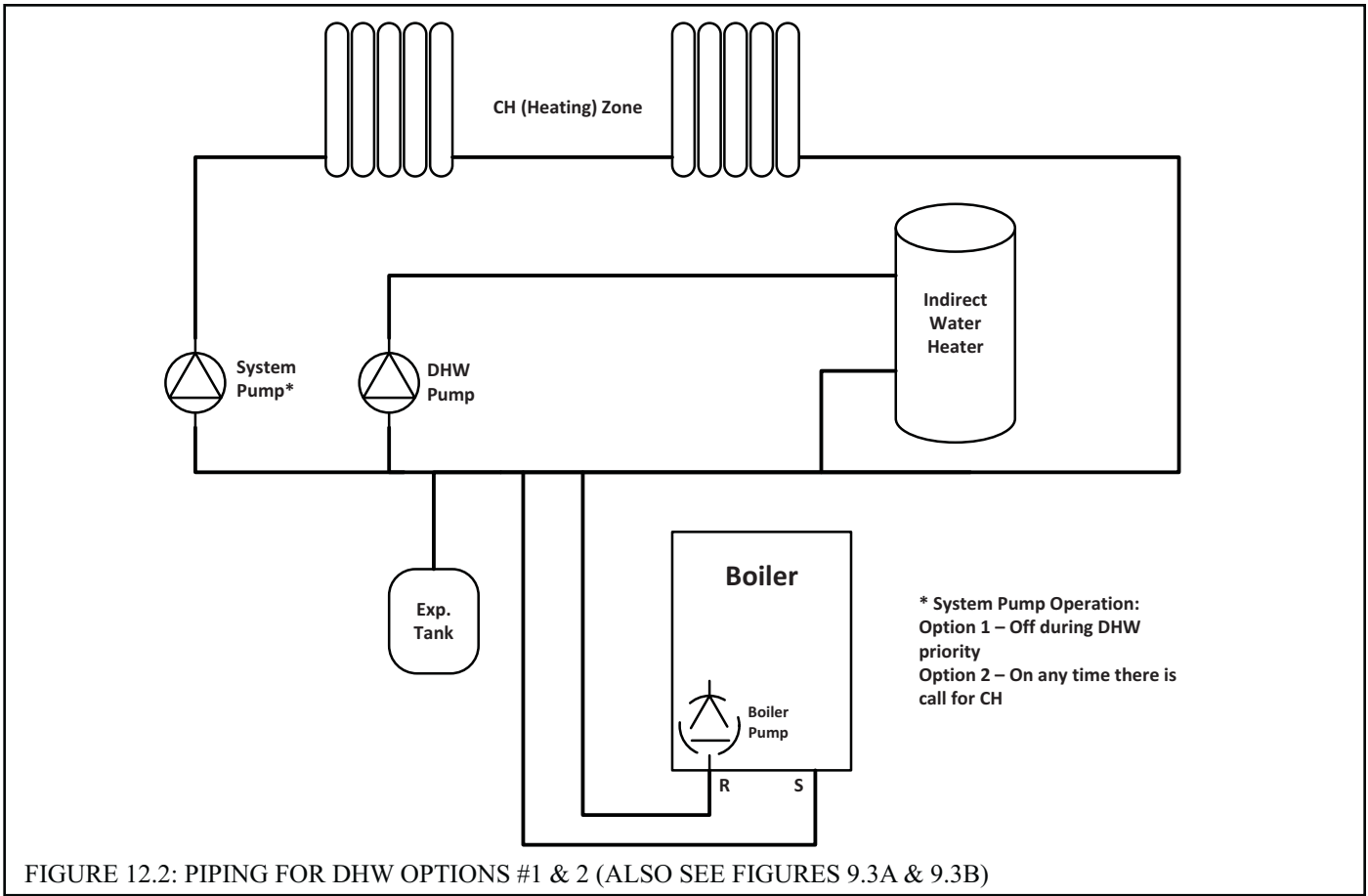

FIGURE 12.2: PIPING FOR DHW OPTIONS #1 & 2 (ALSO SEE FIGURES 9.3A & 9.3B)

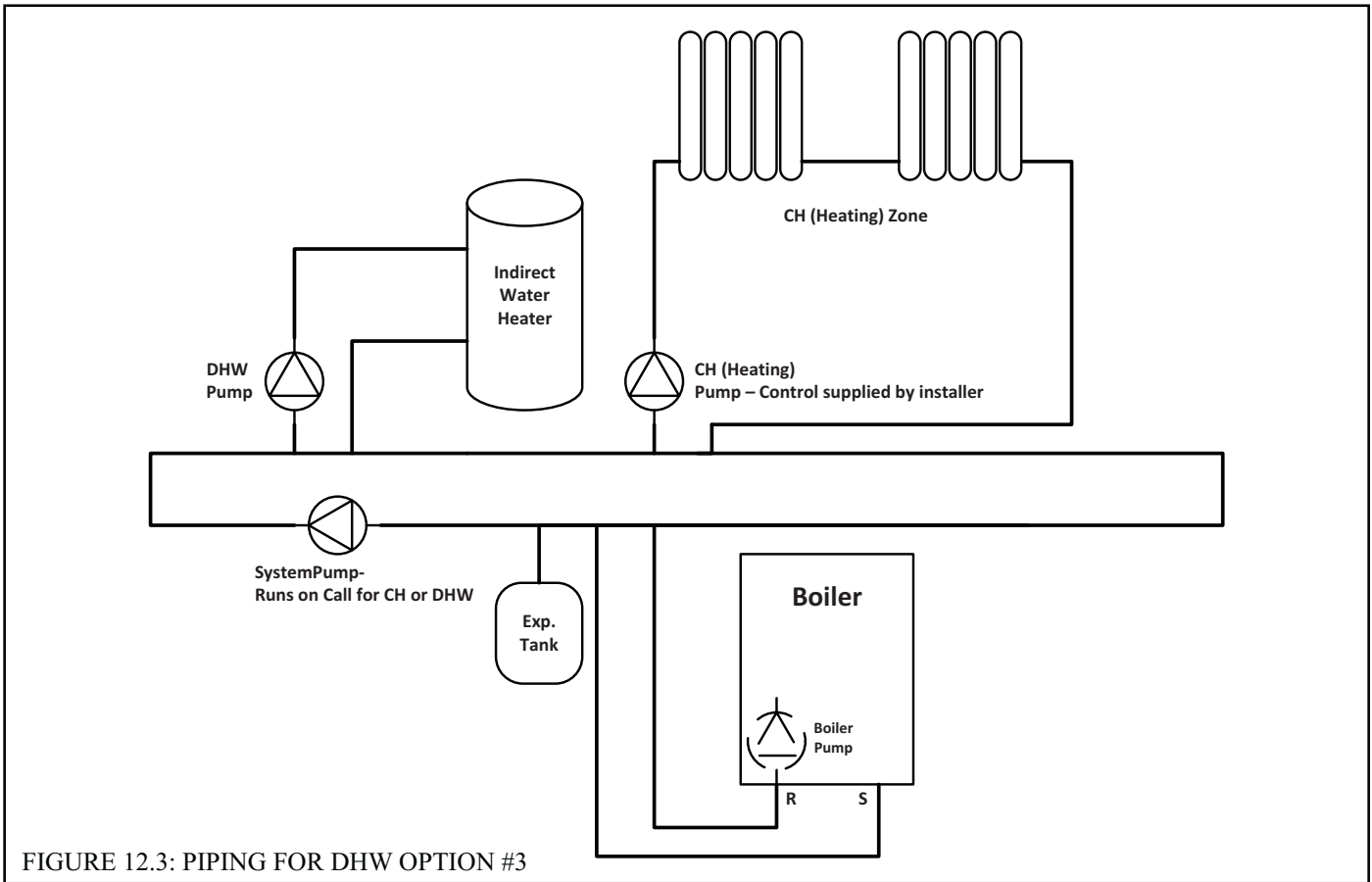

FIGURE 12.3: PIPING FOR DHW OPTION #3

**DHW Priority** - Like all boilers, the Phantom is capable of regulating only one target boiler water temperature at any given time. This means that priority must be given to either the CH or DHW target temperature. For this reason, the Phantom gives priority to the DHW demand for the first 60 minutes during which both calls for CH and DHW continuously exist. If there are still simultaneous calls for DHW and CH at the end of this time, the boiler will attempt to maintain the target CH temperature and operate the pump/s needed to satisfy the call for heat. The boiler will once again give priority to the DHW temperature when either of the following events occur:

- The call for CH ends.
- The call for DHW is removed and then restored.

Regardless of the DHW option selected, the target water temperature will always change from that for DHW to CH if the simultaneous demand exceeds 60 min.

- 4) Pressing the ADVANCED button on the configuration menu takes the user to the Advanced Configuration menu. This menu allows the user to access rarely needed configuration options. These include:

**FACTORY SET** - This button allows the user to restore all factory configuration and setting options. This function can be used to restore all factory settings if a large number of settings are suspect or if the original control is replaced by one that is programmed for use on another size Phantom. Pressing this button brings up the screen shown in Figure 12.1. Press the model number button until the desired model number is reached. When the selection is changed, this button will flash. When the desired model is reached, press SET to select it. When this change is accepted by the control, the button will stop flashing. Press EXIT to Return to the Advanced Configuration Menu. Repeat the set-up process that starts at the beginning of this Section (XII).



**Asphyxiation Hazard. Boiler type is factory set and must match the boiler model. Only change the boiler type setting if you are installing a new or replacement control. The boiler type setting determines minimum and maximum blower speeds. Incorrect boiler type can cause hazardous burner conditions and improper operation that may result in property loss, physical injury or death.**

Table 12.4: Summary of Target Temp and Pump Behavior

DHW Option #	Description	Status of:	Demands				
			None	CH Only	DHW Only	CH+DHW (<60 min)	CH+DHW (>60 min)
1	System Pump used for CH only (Fig. 12.2). DHW priority pumping.	Boiler Pump	OFF	ON	ON	ON	ON
		DHW Pump	OFF	OFF	ON	ON	OFF
		System Pump	OFF	ON	OFF	OFF	ON
		Target Temp	NONE	CH	DHW	DHW	CH
2	System Pump used for CH only (Fig. 12.2). No DHW priority pumping.	Boiler Pump	OFF	ON	ON	ON	ON
		DHW Pump	OFF	OFF	ON	ON	ON
		System Pump	OFF	ON	OFF	ON	ON
		Target Temp	NONE	CH	DHW	DHW	CH
3	System Pump used for both CH and DHW (Fig. 12.3).	Boiler Pump	OFF	ON	ON	ON	ON
		DHW Pump	OFF	OFF	ON	ON	OFF
		System Pump	OFF	ON	ON	ON	ON
		Target Temp	NONE	CH	DHW	DHW	CH

### C. Changing Settings

Use the Settings Menu to change temperature setpoints and to temporarily lock the boiler in high or low fire. On a new installation configure the boiler first, then go to the Settings Menu. A map of the Settings Menu structure is shown in Figure 12.5. To change settings:

- 1) From the Home Screen (shown in Figure 12.0) , press “MENU” to enter the Main Menu:
  - a) Press “SETTINGS”
  - b) When prompted for a password, use the “+1” key to raise the password to “005”. Press SUBMIT, then NEXT (if you accidentally scroll past 005, press EXIT to return to the main menu and start over).
  - c) Review the Warning and press ACCEPT to continue to the Settings Menu.
  - d) Note: If you go from the Configurations Menu to the Settings Menu without returning to the Home Screen, you will not have to reenter a password.
- 2) CH Settings - Press CH to change the target supply water temperature setting.
  - a) If outdoor reset is disabled, only one CH setpoint exists. The boiler will always attempt to maintain this temperature during a call for CH. To change the setting, touch the button containing the current setting. Adjust the temperature using the “+” and “-” arrows shown and press SET to save the change (also see “How to Change Settings” in Figure 12.5).
  - b) If outdoor reset is enabled, there are a total of four settings that can be changed (also see Figures 12.5 and 12.6):
    - **Max Supply Setpoint** - This is the maximum permissible supply setpoint temperature, regardless of how low the outdoor temperature is.
    - **Min Supply Setpoint** - This is the minimum permissible supply setpoint, regardless of how high the outdoor temperature is.
    - **Max Outdoor Temp** - At or above this setting, supply setpoint is equal to the “Min Supply Setpoint”
    - **Min Outdoor Temp** - At or below this setting, supply setpoint is equal to the “Max Supply Setpoint”

Pressing the GRAPH button on either the CH Outdoor Reset -1 or CH Outdoor Reset -2 screen allows any of the above four outdoor reset settings to be changed while viewing the other three. This graph is for reference only - it does not scale with changes to the ODR settings.

- c) If Warm Weather Shut-Down (WWSD) is enabled, a NEXT button will be present on the CH-Outdoor Reset - 2 screen. This screen allows the user to set the **WWSD Outdoor Temperature**. This is the outdoor temperature above which the boiler will ignore a call for heat from the thermostat.



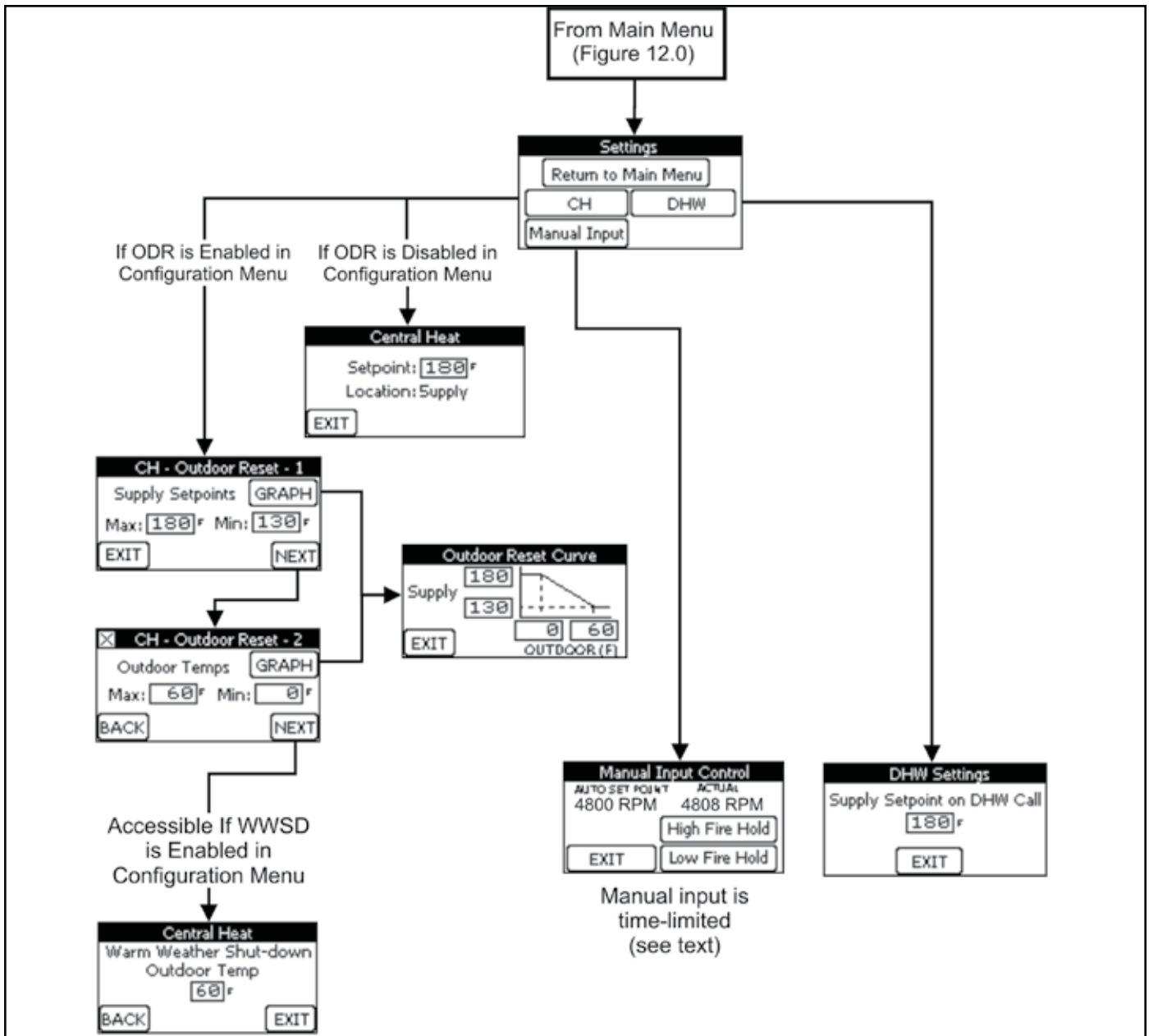

### How to Change Settings

1) Touch value to be changed  
Note: If there is no box around value it cannot be changed on this screen

2) Above screen will appear. Use appropriate "+" and "-" keys to obtain desired setting.  
3) Press SET to save change. To restore original setting before SET is pressed, press CANCEL

4) After SET is pressed, original screen will be displayed with new setting.

FIGURE 12.5: SETTINGS MENU (SEE PART C FOR ADDITIONAL INFORMATION)

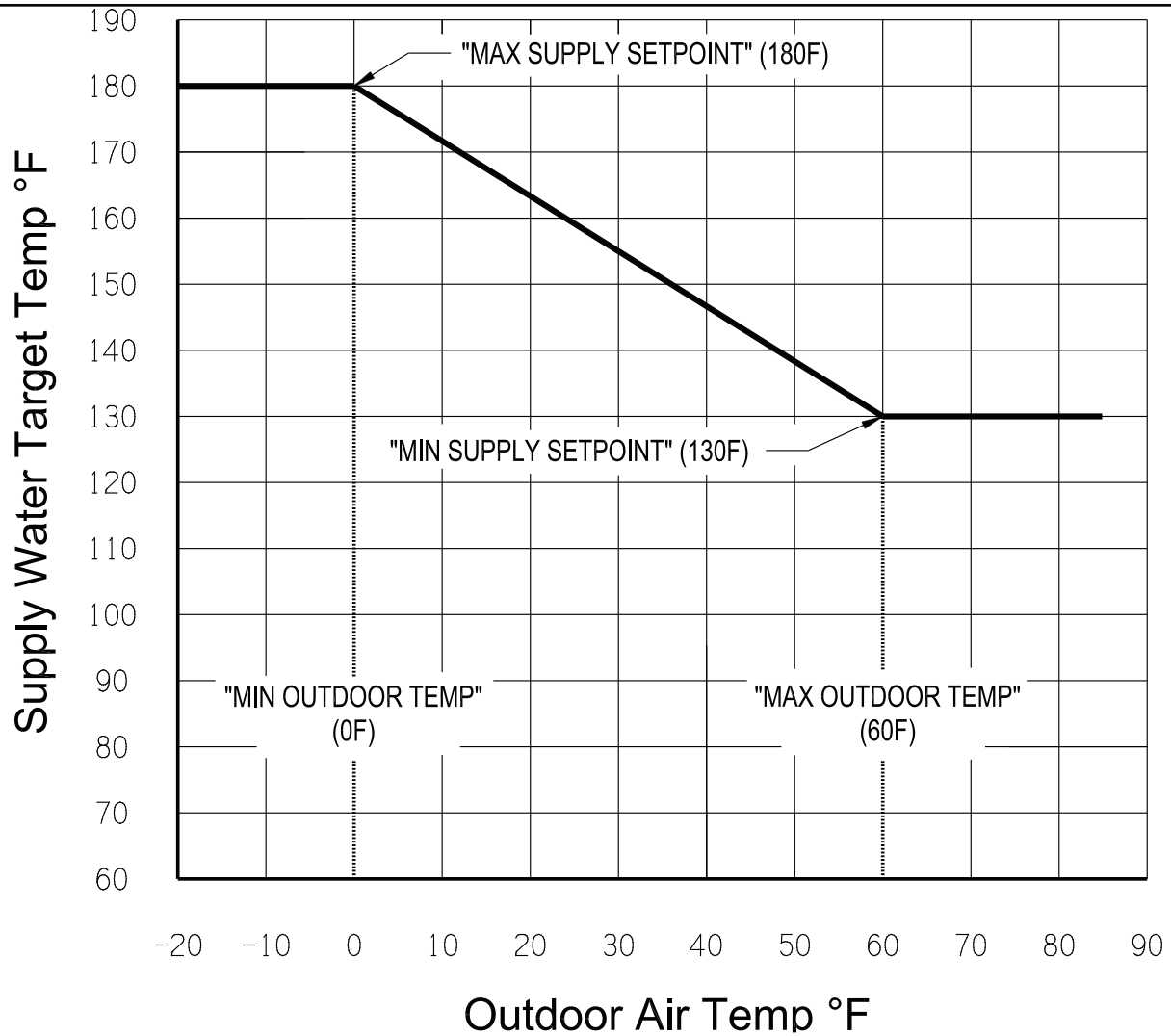

FIGURE 12.6: OUTDOOR RESET CURVE (DEFAULT SETTINGS SHOWN)

- 3) DHW Settings - From the Settings Menu, press the DHW button to change the setpoint temperature when the boiler is responding to a call for DHW. The “DHW Setpoint” is the setpoint of the boiler supply temperature during a call for DHW. Control of the potable water temperature is accomplished using the thermostat on the storage type indirect water heater.
- 4) Manual Input - From the settings menu, press the MANUAL INPUT button to temporarily lock the boiler into either high or low fire (Figure 12.5). This menu is normally used during the performance of combustion tests. Restore automatic operation by pressing the AUTO FIRE Button. If AUTO FIRE is not pressed, the boiler will remain in manual input until one the following occurs:
  - 12 minutes and 45 seconds passes with no touch screen activity
  - The user returns to the Home Screen

## D. Enter Service Contact Information

If desired, the technician can enter contact information so that the owner knows who to contact for future service. To do this:

- 1) From the Main Menu, press the DIAGNOSTICS button.
- 2) From the Diagnostic Menu, press either the INSTALLER or MORE button (only one will be visible depending on whether you are “logged in”).
  - a) If prompted for a password, use the “+1” key to raise the password to “005”. Press SUBMIT, then NEXT (if you accidentally scroll past 005, press EXIT to return to the main menu and start over).
  - b) Review the Warning and press ACCEPT to continue.
- 3) Press ENTER CONTACT.
- 4) Touch the top blank field to enter the first line. When you do this, the keyboard shown in Figure 12.7 will appear. Use the up and down arrows to access additional characters. After entering the first line, press the return key to temporarily save the line.
- 5) Repeat Step 4 for the remaining two lines.
- 6) Press SET to permanently save all three lines into the memory of the display.

## E. Boiler Status Menu

The basic Status Menu is shown in Figure 12.8. It allows the technician to quickly identify how the boiler is currently operating. Specific information available on these screens is as follows:

- 1) Home Screen
  - a) Current Demand - The demand to which the boiler is currently responding. If more than one demand is present, the Current Demands shown will be the one having the highest priority. Typical Current Demands include:
    - **No Demand** - The boiler is not receiving a demand of any type.
    - **Central Heat** - Boiler is receiving a call for space heat
    - **Domestic HW** - Boiler is receiving a call for domestic hot water.
    - **Frost Protection** - The boiler supply, or header temperature fell below 45°F and the boiler is responding to prevent freeze damage to itself.
    - **Off on Warm Weather** - The warm weather shut down option has been selected in the Configuration Menu and the outside air temperature has exceeded the setting at which this function causes the boiler to ignore calls for space heating.
    - **Other Current Demands**, such as “Lead-Lag”, are possible but should never be seen in the applications covered by this manual.
  - b) Active Fault (visible only when there is a problem) - Reverse flashes to indicate certain problems with the boiler or the system. Touching this indicator takes the users to the Diagnostic Menu. See Section XIV for more information.
  - c) Supply - Current boiler supply temperature.

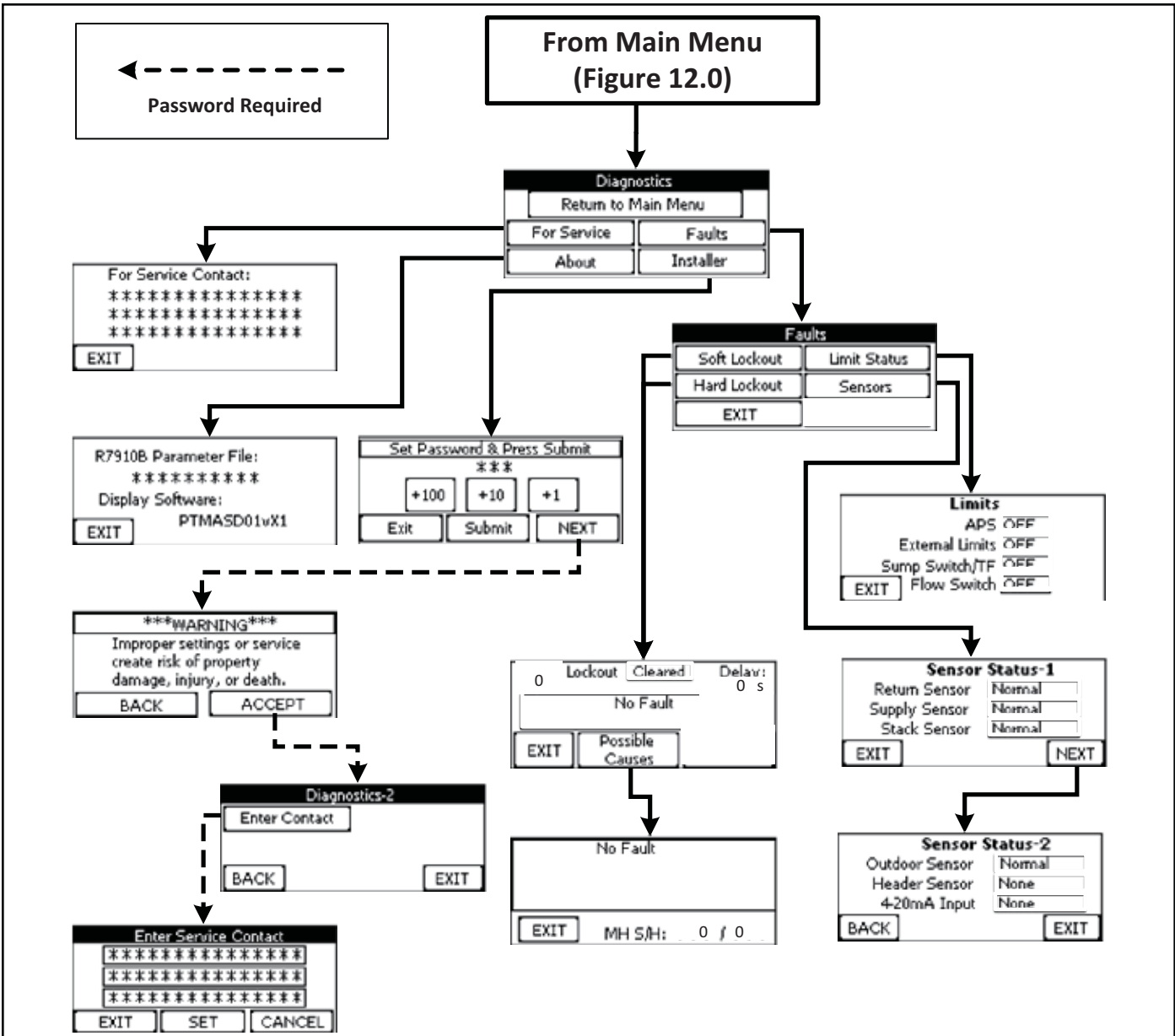

### How to Enter Service Contact Info.

- 1) Touch field to be changed
- 2) Screen below will appear. Use appropriate keys to enter first line.
- 3) Press SET to permanently save all three fields

Enter Service Contact

EXIT SET CANCEL

Use Arrows for More Chars.

W . E .

A	B	C	D	E	F	G	H
I	J	↑	↓	ES	CL	ES	←

Enter Service Contact

W . E . COYOTE HTG

PHOENIX AZ

123 456 7890

EXIT SET CANCEL

Use UP and DOWN Arrows for More

Exit Screen without Saving

Clear Entire Field

Backspace

Temporarily Save Field and Exit

FIGURE 12.7: DIAGNOSTIC MENU (SEE PART D AND SECTION XIV FOR ADDITIONAL INFORMATION)

2) Current Priority Screen:

- a) **Current Demand** - The demand to which the boiler is currently responding. If more than one demand is present, it is the one having the highest priority. See above descriptions under “Home Screen” for specific types of Current Demands.
- b) **Setpoint** - The temperature that the boiler is currently trying to achieve.
- c) **Supply (or Header) Temperature** - The actual water temperature at the current setpoint location (either the boiler supply or header, depending on the demand and what setpoint location was selected in the Configuration Menu).
- d) **Setpoint Source** - Should always read “Local S.P.” in the applications covered by this manual.

3) Boiler Temperatures Screen:

- a) **Supply** - Current water temperature at boiler supply sensor.
- b) **Return** - Current water temperature at boiler return sensor.
- c) **Stack** - Current flue gas temperature near boiler vent connection.
- d) **Header** - Current header sensor temperature. This temperature will only be visible if the header was selected as the setpoint location in the Configuration Menu.

4) Burner Status Screen:

- a) **Burner Status** - Indicates what the burner system is currently doing. Typical Burner Status include:
  - **Standby** - Burner is not needed because there is no call for heat or the target temperature has been reached.
  - **Standby Delay** - Burner is needed, but is being temporarily held off (generally due to a soft lockout - see Diagnostics section).
  - **Safe Start-up** - Control is checking flame circuit before initiating ignition sequence.
  - **Drive Purge** - Waiting for blower to reach pre-purge speed.
  - **Prepurge** - Allowing the blower to clear any residual gas/flue gas from the combustion chamber (10 s).
  - **Drive Light-off** - Waiting for blower to prove that it is at the proper ignition fan speed.
  - **Pre-ignition test** - Test the safety relay and verify that downstream contacts are off.
  - **Pre-ignition** - Energize ignitor with gas valve off to make sure that there is no “false flame” signal.
  - **Direct ignition** - With the ignitor energized, open the gas valve and check for the presence of a flame. Nominal trial for ignition period is 4s.
  - **Running** - Burner is firing.
  - **Post-Purge** - Blower is running after the burner shuts off to clear the combustion chamber of residual gasses. Post purge time is 30s.
  - **Lockout** - Boiler is in a hard lockout (see Diagnostic Section).
- b) **Active Fault** (visible only when there is a problem) - Reverse flashes to indicate a problem with the boiler or the system. Touching this indicator takes the user to the Diagnostic Menu. See Section XIV for more information.
- c) **Hold Delay (Visible only during soft lockout)** - Indicates remaining time before next ignition sequence.
- d) **Flame Signal** - Indicates the strength of the flame signal in DC micro-amps.

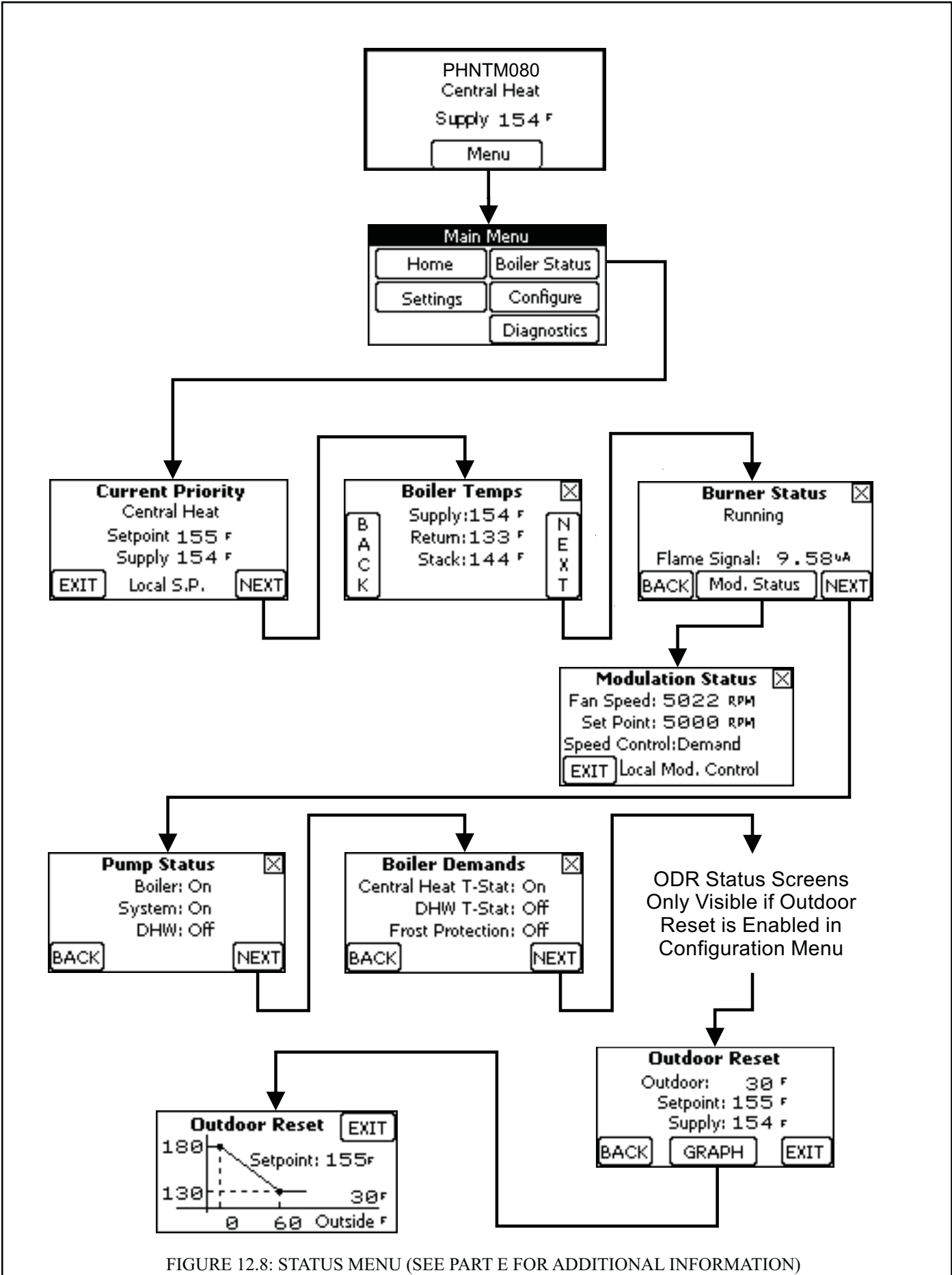

FIGURE 12.8: STATUS MENU (SEE PART E FOR ADDITIONAL INFORMATION)

5) Modulation Status Screen:

- a) **Fan Speed** - Current actual fan speed in RPM
- b) **Setpoint** - Current target fan speed in RPM
- c) **Speed Control** - Indicates the function currently controlling fan speed (and therefore firing rate). Typical possibilities include:
  - **Off** - Blower is off.
  - **Burner system** - The blower speed is being determined by that needed for pre-purge, ignition, or post purge.
  - **Demand** - Fan speed is being determined by the “PID” function in the control. This function regulates the fan speed based on a combination of past and present differences between the target water temperature and the actual water temperature.
  - **Supply Limit** - The supply temperature is above 185°F and the input is being limited to reduce the likelihood of high limit activation.
  - **Delta-T limit** - The temperature rise across the boiler has exceeded approximately 54°F and the input is being limited to reduce the likelihood of a soft lockout.
  - **Stack Limit** - The flue temperature is above 200°F and the input is being limited to reduce the likelihood of a hard lockout.
  - **Min Mod** - The input is not allowed to go lower because the minimum allowable fan speed has been reached.
  - **Manual** - The boiler is set in manual input mode (see Settings Menu).
- d) **Modulation Source** - Should always read “Local Mod. Control” in the applications covered by this manual.

6) Pump Status:

- a) **Boiler** - Indicates whether the boiler pump is currently powered.
- b) **System** - Indicates whether the system pump is currently powered.
- c) **DHW** - Indicates whether the DHW pump is currently powered.

7) Boiler Demands:

- a) **Central Heat T’Stat** - Indicates whether the boiler is seeing a call for space heat from a thermostat.
- b) **DHW T’ Stat** - Indicates whether the boiler is seeing a call from a domestic hot water thermostat.
- c) **Frost Protection** - Indicates whether the boiler is seeing a call for frost protection. This demand should never be present unless the boiler supply, or header, temperature is at or below 45°F.

8) Outdoor Reset Screens (only visible when outdoor reset has been enabled in Configuration Menu):

- a) **Outdoor** - Current temperature at outdoor sensor.
- b) **Setpoint** - Current CH setpoint obtained from outdoor reset curve (Figure 12.6).
- c) **Supply (or Header) Temperature** - The actual water temperature at the current setpoint location (either the boiler supply or header, depending on the demand and what setpoint location was selected in the Configuration Menu).
- d) **Outdoor Reset Graph** - Shows all outdoor reset curve settings, the current outdoor temperature, and setpoint. Note: this graph is for reference only and does not scale.

### XIII. Service and Maintenance



#### **WARNING**

- **Asphyxiation Hazard. Fire Hazard. Explosion Hazard.** This boiler requires regular maintenance and service to operate safely. Follow the instructions contained in this manual.
- **Improper installation, adjustment, alteration, service or maintenance can cause property damage, personal injury or loss of life.** Read and understand the entire manual before attempting installation, start-up operation, or service. Installation and service must be performed only by an experienced, skilled, and knowledgeable installer or service agency.



#### **DANGER**

- **Explosion Hazard. Electrical Shock Hazard. Burn Hazard.** This boiler uses flammable gas, high voltage electricity, moving parts, and very hot water under high pressure. Assure that all gas and electric power supplies are off and that the water temperature is cool before attempting any disassembly or service.
- **Do not attempt any service work if gas is present in the air in the vicinity of the boiler.** Never modify, remove or tamper with any control device.



#### **WARNING**

- **This boiler must only be serviced and repaired by skilled and experienced service technicians.**
- **If any controls are replaced, they must be replaced with identical models.**
- **Read, understand and follow all the instructions and warnings contained in all the sections of this manual.**
- **If any electrical wires are disconnected during service, clearly label the wires and assure that the wires are reconnected properly.**
- **Never jump out or bypass any safety or operating control or component of this boiler.**
- **Assure that all safety and operating controls and components are operating properly before placing the boiler back in service.**
- **Annually inspect all vent gaskets and replace any exhibiting damage or deterioration.**
- **Burn Hazard.** This boiler contains very hot water under pressure. Do not unscrew any pipe fittings nor attempt to disconnect any components of this boiler without positively assuring the water is cool and has no pressure. Always wear protective clothing and equipment when installing, starting up or servicing this boiler to prevent scald injuries. Do not rely on the pressure and temperature gauges to determine the temperature and pressure of the boiler. This boiler contains components which become very hot when the boiler is operating. Do not touch any components unless they are cool.
- **Respiratory Hazard.** Boiler materials of construction, products of combustion and the fuel contain alumina, silica, heavy metals, carbon monoxide, nitrogen oxides, aldehydes and/or other toxic or harmful substances which can cause death or serious injury and which are known to the state of California to cause cancer, birth defects and other reproductive harm. Always use proper safety clothing, respirators and equipment when servicing or working nearby the appliance.
- **Failure to follow all instructions in the proper order can cause personal injury or death.** Read all instructions, including all those contained in component manufacturers manuals which are provided with the boiler before installing, starting up, operating, maintaining or servicing.
- **All cover plates, enclosures and guards must be in place at all times.**



## NOTICE

Warranty does not cover boiler damage or malfunction if the following steps are not performed at the intervals specified.

1) **Continuously:**

- a. **Keep the area around the boiler** free from combustible materials, gasoline and other flammable vapors and liquids.
- b. **Keep the area around the combustion air inlet terminal** free from contaminants.
- c. **Keep the boiler room ventilation openings** open and unobstructed.

2) **Monthly Inspections:**

- a. **Inspect the vent piping and outside air intake piping** to verify they are open, unobstructed and free from leakage or deterioration. Call the service technician to make repairs if needed.
- b. **Inspect the condensate drain system** to verify it is leak tight, open and unobstructed. Call the service technician if the condensate drain system requires maintenance.
- c. **Inspect the water and gas lines** to verify they are free from leaks. Call the service technician to make repairs if required.

## NOTICE

Water leaks can cause severe corrosion damage to the boiler or other system components. Immediately repair any leaks found.

4) **Annual Inspections and Service:** In addition to the inspections listed above, the following should be performed by a service technician once every year.

- a. **Follow the procedure** for turning the boiler off found in the Lighting and Operating Instructions, on page 90.
- b. **Turn off all power** to the boiler.
- c. **Inspect the wiring** to verify the conductors are in good condition and attached securely.



## CAUTION / ATTENTION

Electrical Shock Hazard. Label all wires prior to disconnection when servicing controls. Wiring errors can cause improper and dangerous operation. Verify proper operation after servicing.

Au moment de l'entretien des commandes, étiquetez tous les fils avant de les débrancher. Les erreurs de câblage peuvent nuire au bon fonctionnement et être dangereuses. S'assurer que l'appareil fonctionne adéquatement une fois k'entretien terminé.

- d. **Verify that the gas shutoff** shown in Figure 8.1 is closed
- e. **Disconnect the flexible gas line** at the gas valve flare connection (Figure 13.0).



## WARNING

Fire Hazard. Explosion Hazard. Always use a back-up wrench on the flare connection when making or breaking this connection as shown in Figure 13.0. Failure to do so can cause adjacent threaded connections to loosen or damage to the gas valve. Check all internal gas piping for leaks any time it is disconnected or disturbed during servicing.

- f. **Unplug the electrical connection** to the gas valve.
- g. **Disconnect the air proving switch tube** from the gas valve outlet tap.
- h. **Unplug the power and speed control cables** from the blower.

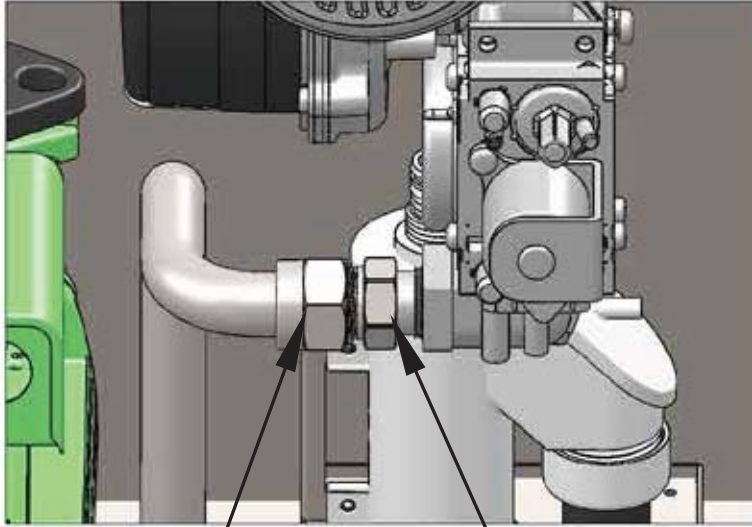

FLEXIBLE GAS LINE  
CONNECTION

WHEN DISCONNECTING FLEXIBLE GAS LINE  
PLACE A BACKUP WRENCH ON THIS NUT TO  
PREVENT DAMAGE TO THE GAS VALVE.

FIGURE 13.0: DISCONNECTING FLEXIBLE GAS LINE

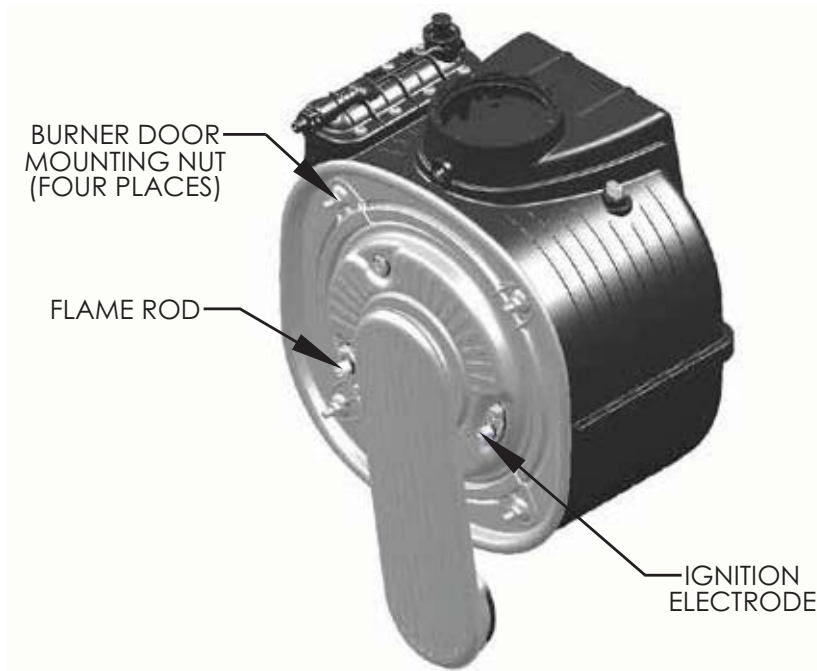

BURNER DOOR  
MOUNTING NUT  
(FOUR PLACES)

FLAME ROD

IGNITION  
ELECTRODE

FIGURE 13.1: FLAME IONIZATION ELECTRODE AND IGNITION ELECTRODE LOCATION

- i. **Unplug the ignition, ground, and flame rod wires** from the ignition electrode and the flame rod (Figure 13.1).
- j. **Use a 10mm wrench to remove the four nuts** securing the fire door to the heat exchanger (Figure 13.1). Carefully remove the door/blower/gas valve assembly from the heat exchanger, being careful not to damage the refractory insulation on the inside of the door (see Refractory Warning on next page) or the electrodes.
- k. **Inspect the heat exchanger combustion chamber and vacuum** any debris found on the coil surfaces. If necessary, the coils may be brushed with a nonabrasive, nonmetallic brush. Do not use cleaning agents, solvents, acid or alkali products of any type to clean the heat exchanger .
- l. **Inspect the target wall and fire door insulation.** If either shows signs of damage, it must be replaced.
- m. **Inspect the burner for heat damage** or other deterioration. Use a non-metallic brush or source of compressed air to clean off dust or debris from ports.
- n. **Inspect the ignition electrode and flame rod** for deposits. Clean any found with steel wool. Do not use sand paper or Emory cloth for this cleaning. Inspect the ceramic portion of both of these parts for cracks and replace if any are found. Verify that the ignition electrode gap is within the range shown in Figure 13.2
- o. **Inspect the blower gas valve assembly**, looking for dust, lint, or other debris that may have been drawn into this assembly. Excessive deposits may be vacuumed out.

The blower/gas valve assembly used on the 150MBH and 180MBH may be disassembled to expose the “swirl plate” (see Parts Section for identification of parts in this assembly). If it is necessary to clean the swirl plate, carefully note the orientation of all parts during disassembly and use care not to damage the swirl plate vanes. The venturi assembly used on the 80, 100, and 120 cannot be removed from the blower.

Inspect all rubber and plastic components on the blower/gas valve assembly, looking for deterioration. Replace blower and/or gas valve if deterioration is found.

- p. **Inspect and clean the condensate trap.** Place a bucket under the condensate cleanout cap on the bottom of the boiler (Figure 2.1) to catch water in the trap as well as the ball and ball support. Unscrew the cap, being careful not to lose the ball or ball support. Flush any debris found in the trap with water – do not use other cleaning agents. Reassemble the trap as shown in Figure 13.3.



## WARNING

**Asphyxiation Hazard. Do not operate the boiler without the ball and ball support in place. Doing so could result in flue gas leakage into the indoors resulting in personal injury or death from Carbon Monoxide (CO) poisoning.**

## NOTICE

**Attempting to clean the heat exchanger or trap with anything other than water could result in condensate backup, causing the boiler to shut-down.**

- q. **Reinstall the fire door/blower/gas valve assembly**, following the above steps in reverse order.



## CAUTION

**Do not over tighten fire door mounting nuts. Doing so could break the fire door mounting studs. If any of these studs are damaged, the heat exchanger must be replaced. Use of a short 10mm box wrench will reduce the risk of damaging these studs.**

- r. **Inspect the vent system to verify that:**
  - All gaskets and joints between the boiler heat exchanger and terminal are leak tight.
  - All supports are intact and vent system is properly pitched
  - All pipe is in good condition. Look for damage such as cracks, heat distortion, discoloration, and embrittlement. If any such damage is found, the pipe must be replaced and the cause of the damage identified.
  - Vent/Intake terminals are in good condition, free from blockages, and still correctly located relative to doors, windows, decks, etc.
  - There is no gasoline, flammable liquids/vapors, or halogen based products stored in the vicinity of the vent or inlet terminals. Also verify that there are no chemical products containing chlorine, chloride based salts, chlorofluorocarbons, paint removers, cleaning solvents, or detergents stored near the air intake terminal.

## **Important Product Safety Information** **Refractory Ceramic Fiber Product**

### **Warning:**

The Repair Parts list designates parts that contain refractory ceramic fibers (RCF). RCF has been classified as a possible human carcinogen. When exposed to temperatures above 1805°F, such as during direct flame contact, RCF changes into crystalline silica, a known carcinogen. When disturbed as a result of servicing or repair, these substances become airborne and, if inhaled, may be hazardous to your health.

### **AVOID Breathing Fiber Particulates and Dust**

### **Precautionary Measures:**

Do not remove or replace RCF parts or attempt any service or repair work involving RCF without wearing the following protective gear:

1. A National Institute for Occupational Safety and Health (NIOSH) approved respirator
  2. Long sleeved, loose fitting clothing
  3. Gloves
  4. Eye Protection
- Take steps to assure adequate ventilation.
  - Wash all exposed body areas gently with soap and water after contact.
  - Wash work clothes separately from other laundry and rinse washing machine after use to avoid contaminating other clothes.
  - Discard used RCF components by sealing in an airtight plastic bag. RCF and crystalline silica are not classified as hazardous wastes in the United States and Canada.

### **First Aid Procedures:**

- If contact with eyes: Flush with water for at least 15 minutes. Seek immediate medical attention if irritation persists.
- If contact with skin: Wash affected area gently with soap and water. Seek immediate medical attention if irritation persists.
- If breathing difficulty develops: Leave the area and move to a location with clean fresh air. Seek immediate medical attention if breathing difficulties persist.
- Ingestion: Do not induce vomiting. Drink plenty of water. Seek immediate medical attention.

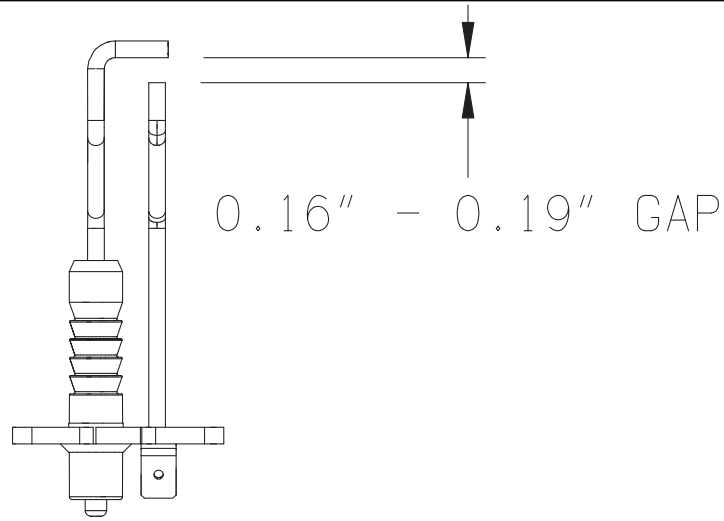

FIGURE 13.2: IGNITION ELECTRODE GAP

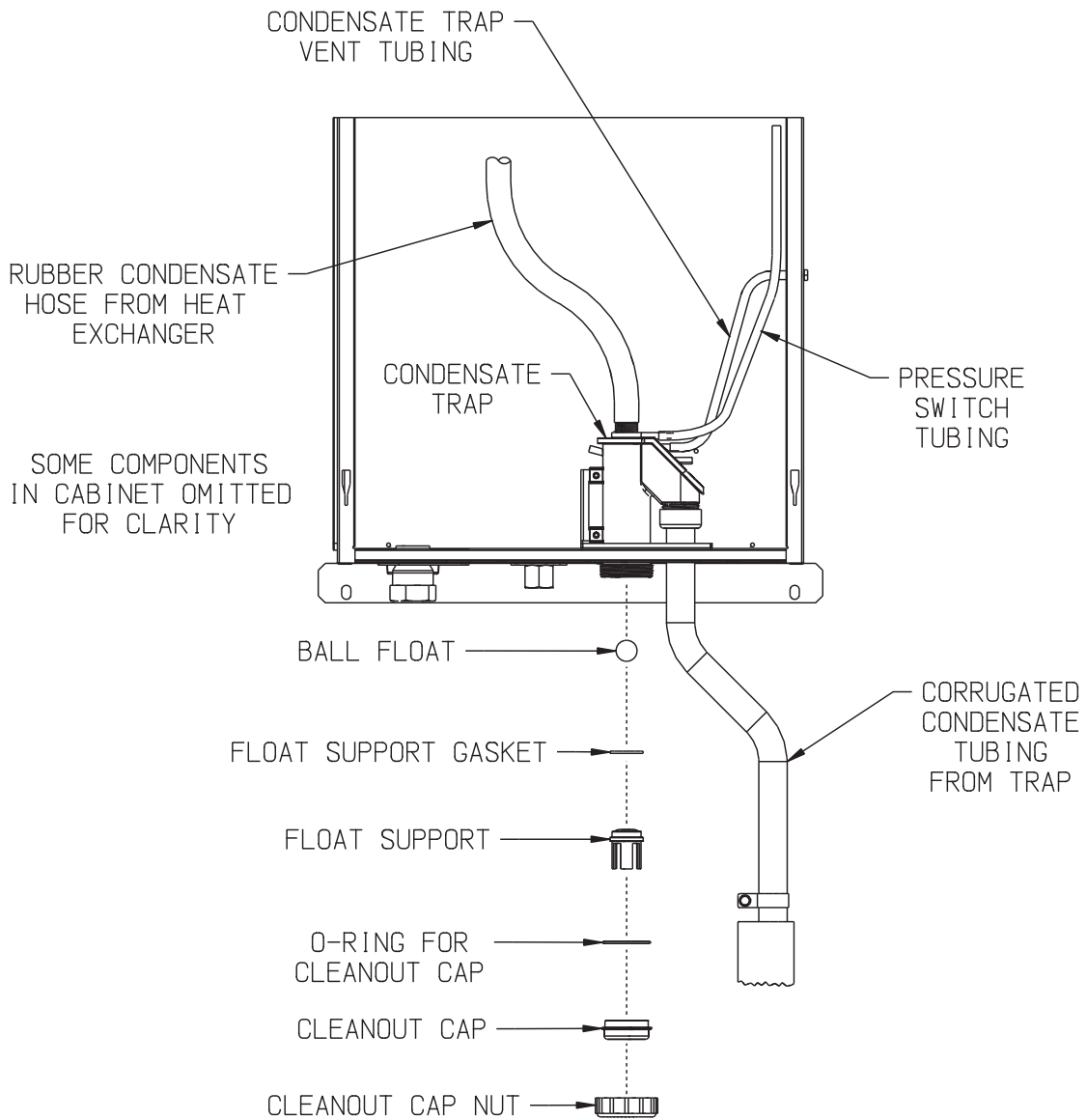

FIGURE 13.3: CONDENSATE TRAP EXPLODED PARTS VIEW

Refer to Part VII (Venting) to re-assemble any vent system components that are disassembled during this inspection. Also refer to Part VII for details on supporting, pitching, and terminating the vent system.

- s. **Replace any wiring** which has been disconnected.
- t. **Inspect the hydronic system.** Look for leaks and repair any found. If system contains antifreeze, or other additives, test and/or maintain them as directed by the additive manufacturer. See Part XI (Start-up and Checkout) for important information on boiler water and the use of boiler water additives.
- u. **Test the flow switch.** To do this:
  - Start with the boiler in standby.
  - Either close a shut-off in the boiler loop or unplug the boiler pump at connector L1. (Figure 10.6)
  - Initiate a call for heat and confirm that the boiler shows an Active Fault indicating that the flow switch is open.



## CAUTION

**If burner comes on with no flow through the boiler, there is a problem with the flow switch. Turn the boiler off immediately. Failure to do so could cause severe heat exchanger damage.**

- v. **Follow ALL instructions in Part XI (Start-up and Checkout)** to place the boiler back in service, including the performance of a combustion test.

## XIV. Troubleshooting



### DANGER

- **Explosion Hazard. Electrical Shock Hazard. Burn Hazard.** This boiler uses flammable gas, high voltage electricity, moving parts, and very hot water under high pressure. Assure that all gas and electric power supplies are off and that the water temperature is cool before attempting any disassembly or service.
- Do not attempt any service work if gas is present in the air in the vicinity of the boiler. Never modify, remove or tamper with any control device.



### WARNING

- This boiler must only be serviced and repaired by skilled and experienced service technicians.
- If any controls are replaced, they must be replaced with identical models.
- Read, understand and follow all the instructions and warnings contained in all the sections of this manual.
- If any electrical wires are disconnected during service, clearly label the wires and assure that the wires are reconnected properly.
- Never jump out or bypass any safety or operating control or component of this boiler.
- Read, understand and follow all the instructions and warnings contained in ALL of the component instruction manuals.
- Assure that all safety and operating controls and components are operating properly before placing the boiler back in service.

The following pages contain trouble shooting tables for use in diagnosing control problems. When using these tables the following should be kept in mind:

- 1) This information is only meant to be used by a professional heating technician as an aid in diagnosing boiler problems.
- 2) Where applicable, follow all precautions outlined in the Section XI (Start-up and Checkout).
- 3) All controls on the boiler are tested at least once in the manufacturing process and a defective control or component is generally the least likely cause. Before replacing a component, try to rule out all other possible causes.

### A. Using the Diagnostics Menu

The plain text display provided with this boiler provides an easy means of identifying most common problems. In the event that the control system detects a problem, such as an open limit or defective sensor, the Active Fault button shown in Figure 14.0 will appear and flash on both the Home Screen and the Burner Status Screen. Touching either Active Fault button will take the user to the Diagnostics Menu. From here, press the flashing button on each successive screen to reach a list of possible causes. In the case of a defective temperature sensor, a defect indicator will also show up on the status screens where the corresponding temperature is normally displayed. See Figure 14.0 for an example of this.

The complete Diagnostics Menu is shown in Figure 12.7. The screens on this menu provide the following information:

- 1) **For Service Contact** - Displays the service contact information entered in Section XII, Step D.
- 2) **About** - Displays the software versions for both the boiler control (R7910B) and the display
- 3) **Fault Menu** - Provides status of different types of faults by category. When a particular fault exists, the button for that category of faults will flash (see Figure 14.0 for an example of a faulty supply sensor). In the example shown in Figure 14.0, both the Sensor and Soft Lockout buttons flash on the Fault Menu because a defective supply sensor also causes a soft lockout. Fault categories include:

- a) **Soft Lockout** - A soft lockout prevents the boiler from firing until the problem has been corrected and, in some cases, a specified amount of time (up to 1 hour, depending on the nature of the fault) has passed. An example of the Fault Menu structure during a soft lockout is shown in Figure 14.0
- b) **Hard Lockout** - A hard lockout prevents the boiler from firing until the problem has been corrected AND the boiler has been manually reset. This can either be done at the boiler control itself or on the hard lockout screen. An example of the Fault Menu structure during a hard lockout is shown in Figure 14.2.  
A hard lockout closes the alarm contact connections on the low voltage PCB.
- c) **Sensors** - The Sensor Screens show the status of all sensors. Possible states of the sensors include:
- **None** - The boiler control (R7910B) is not looking for an input from this sensor
  - **Normal** - The sensor is working normally
  - **Shorted** - There is a short between the boiler control (R7910B) and the sensor or the sensor is defective
  - **Open** - There is a break in the wiring between the boiler control (R7910B) and the sensor or the sensor is defective
  - **Out of Range** - The sensor is defective or is being subjected to electrical noise.
  - **Unreliable** - The sensor is defective or is being subjected to electrical noise.
- d) **Limit Status** - The Limit Status Screen shows the status of all safety limits. Each of these limits is either shown as being ON or OFF. It is important to remember that since all of limits are wired in series, any limit which is in the OFF state will cause all limits “downstream” of it to also appear on this screen as being OFF, regardless of whether or not they actually are. The limits are wired in the following order (also see Figure 10.5):
1. External Limits, including LWCO if used.
  2. Air Proving Switch (APS)
  3. Sump Pressure Switch
  4. Flow Switch

Therefore, in the example shown in Figure 14.1, the Auxiliary limit is known to be closed, the LWCO is known to be open, and the High Limit and Air Pressure switches could be either open or closed.

## **B. Troubleshooting when the Display is Blank**

Use the flow chart in Figure 14.3 to locate the problem when the display is blank or is not readable.

## **C. Operation and Troubleshooting of Boiler Controls Other than the Sola**

For the location of the controls described below, see Figure 14.4.

**Fuses** – This boiler is equipped with two 5 x 20mm fuses:

- **Pump Fuse** – This fuse protects the relay contacts in the boiler control from excessive current draw caused by an oversized or seized pump. The fuse supplied with the boiler is a 6.3A, slow blow type. A replacement fuse is supplied with the boiler. If this fuse blows, look for a seized pump, a short circuit in the pump wiring, or an oversized DHW or system pump. When a Taco 0013 is supplied for the boiler pump, the total draw of the DHW and system pumps cannot exceed 4.3A.
- **24V Fuse** – This fuse protects the transformer from excessive draw and is a 1.6A slow blow type. If this fuse blows, look for a short circuit in the 24V wiring before replacing. A short circuit to ground in field wiring (such as a thermostat wire touching a pipe) will cause this fuse to blow. A replacement fuse is supplied with the boiler



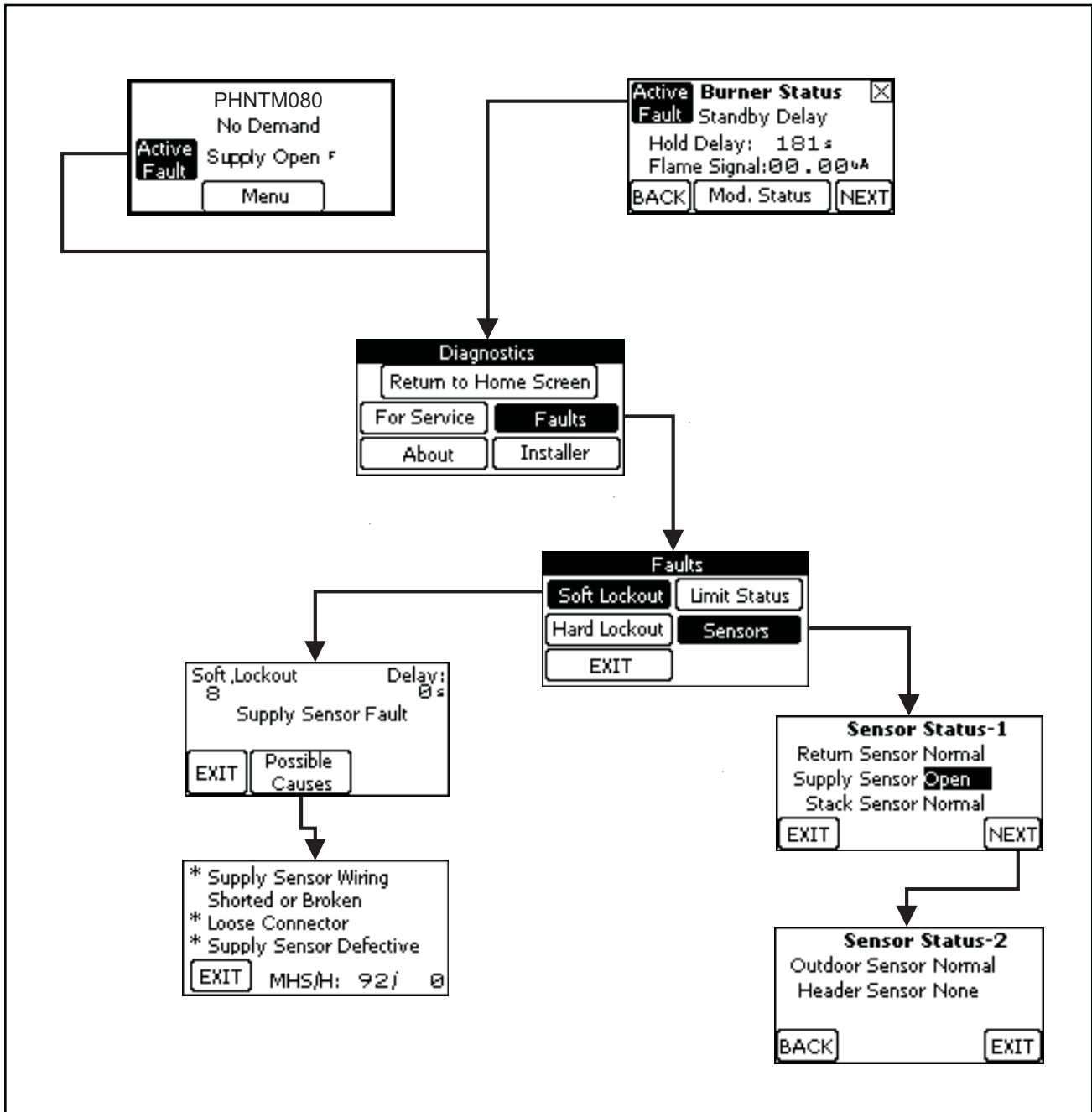

FIGURE 14.0: EXAMPLE OF DIAGNOSTIC MENU DURING SOFT LOCKOUT

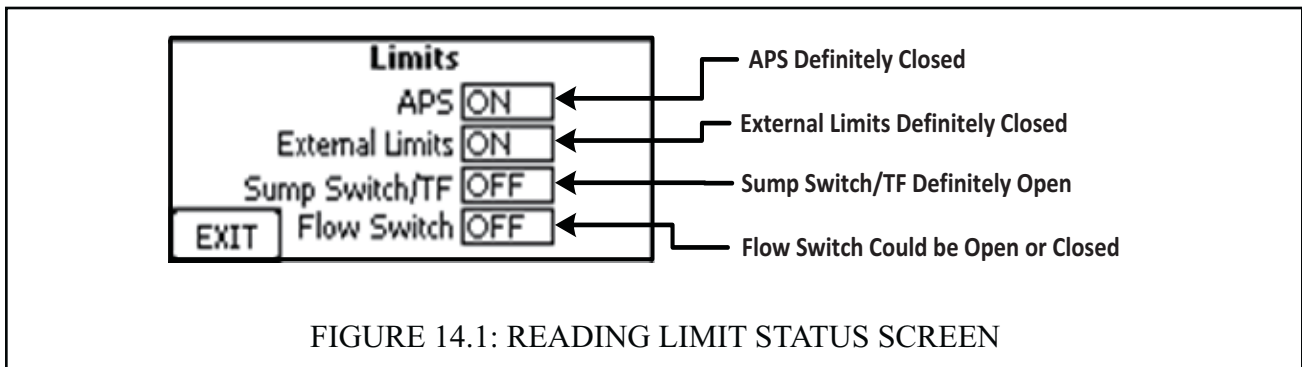

FIGURE 14.1: READING LIMIT STATUS SCREEN

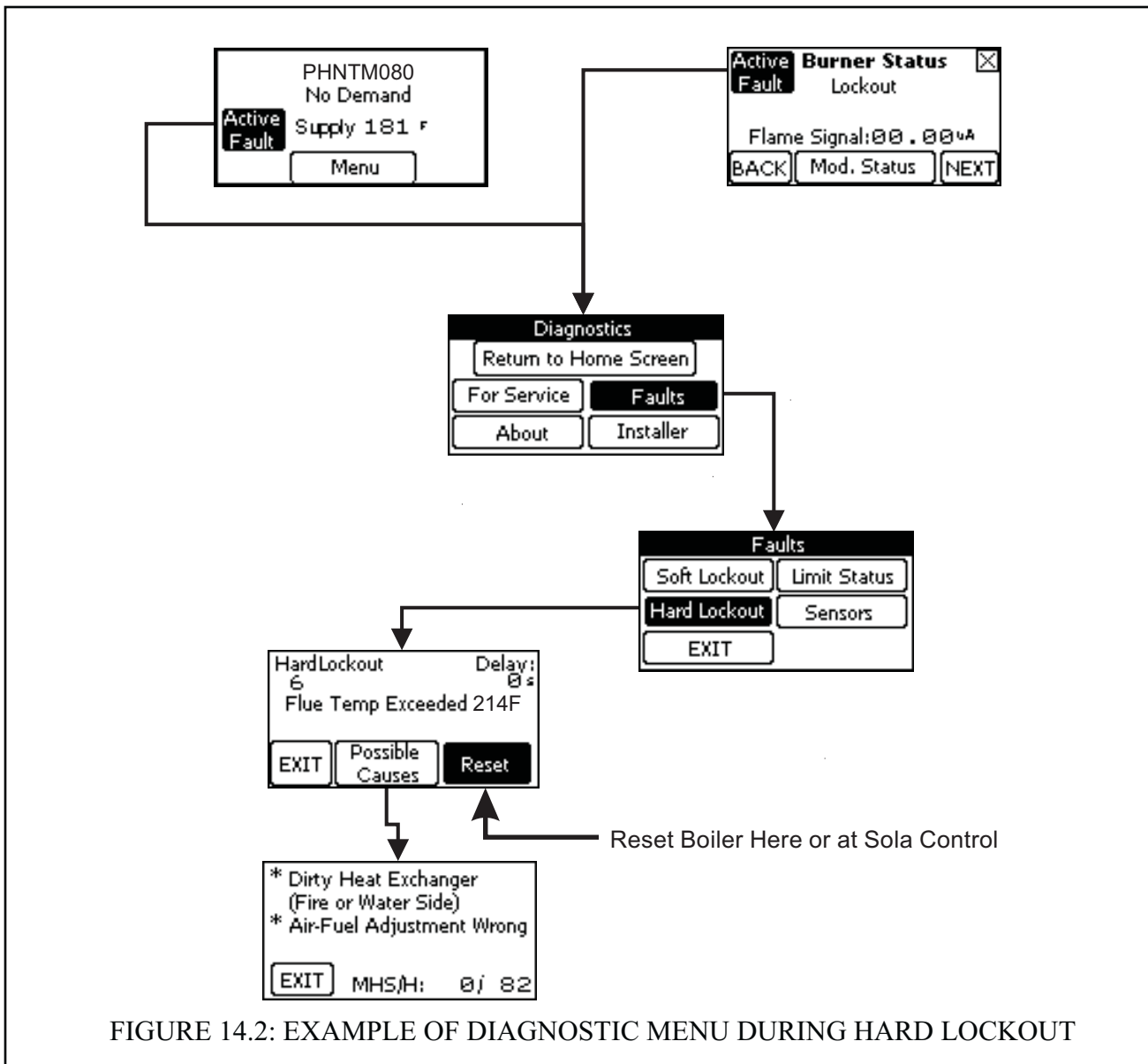

FIGURE 14.2: EXAMPLE OF DIAGNOSTIC MENU DURING HARD LOCKOUT

**Thermal Fuse** – The thermal fuse is designed to prevent boiler operation in the event that the heat exchanger is damaged by excessive flue gas temperatures. It is set to open at 358F and is a one shot non-replaceable device. If this fuse opens, the heat exchanger must be replaced. The thermal fuse is essentially a back-up to the flue gas sensor, which is designed to prevent boiler operation if the flue gas temperature exceeds 210F. .

If the thermal fuse is suspected of having opened, unplug the wire heading to it and check continuity directly across the thermal fuse. If no continuity is present, the heat exchanger needs to be replaced. If continuity is present, the fault lies elsewhere.



## WARNING

**Asphyxiation Hazard. Fire Hazard. Do not attempt to jump or replace the thermal fuse. Doing so may cause a breach of the heat exchanger casing resulting in property damage, personal injury or loss of life.**

**Sump Pressure Switch (SPS)** – This pressure switch is normally closed and monitors the difference in pressures between the boiler cabinet and the sump (the sump pressure is very close to the pressure at the boiler’s vent connection). This switch is piped as shown in Figure 14.5. The SPS is calibrated to open at 3.15 +/- 0.10 inches water column. A blockage in vent system that causes the vent pressure to exceed the SPS set point will cause the burner to shut down and recycle. Likewise, a blockage in the air intake system that causes the vacuum in the cabinet to fall below -3.15 inches will also cause the boiler to shut down and recycle. If this switch opens, look for a blockage in the vent or air intake system.

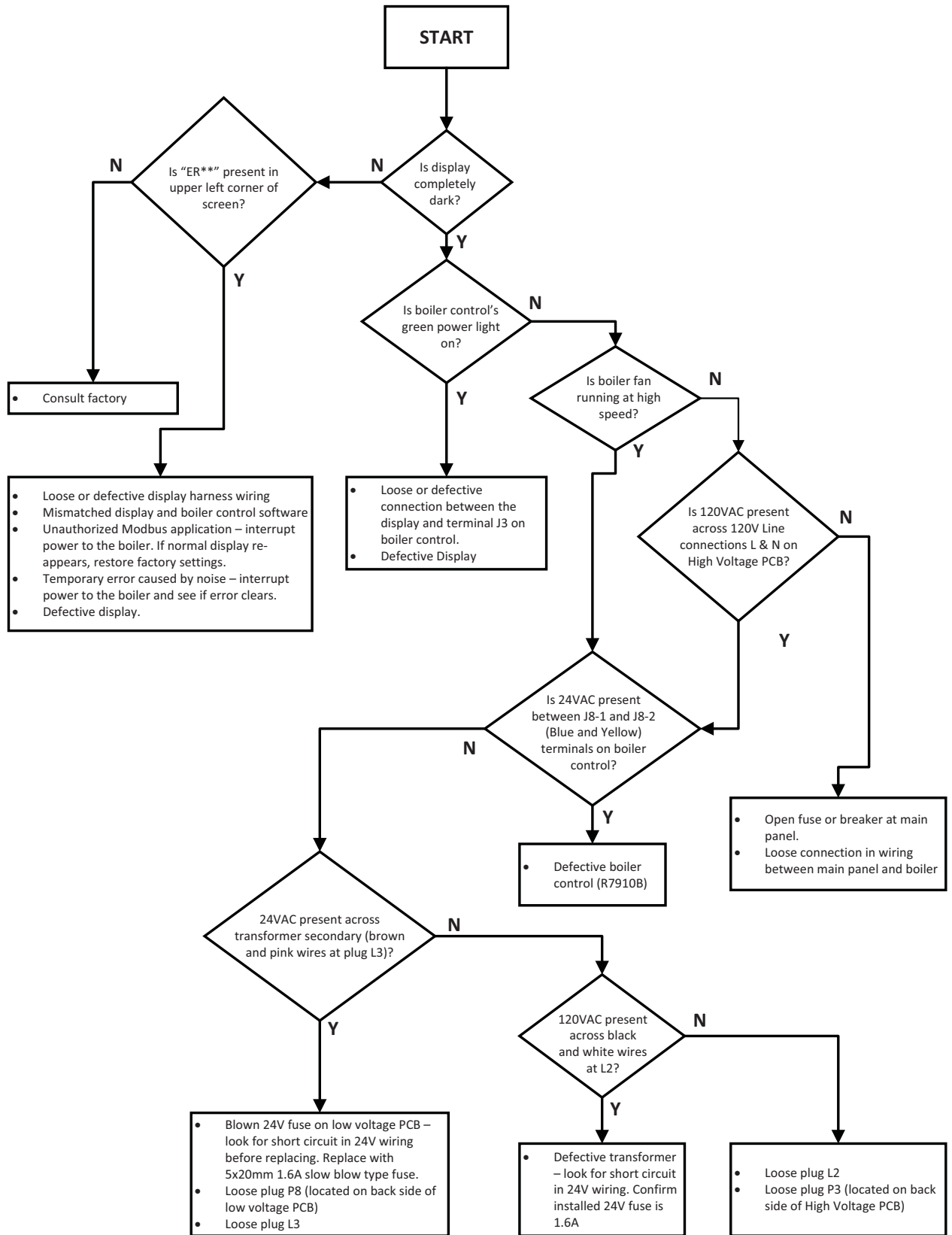
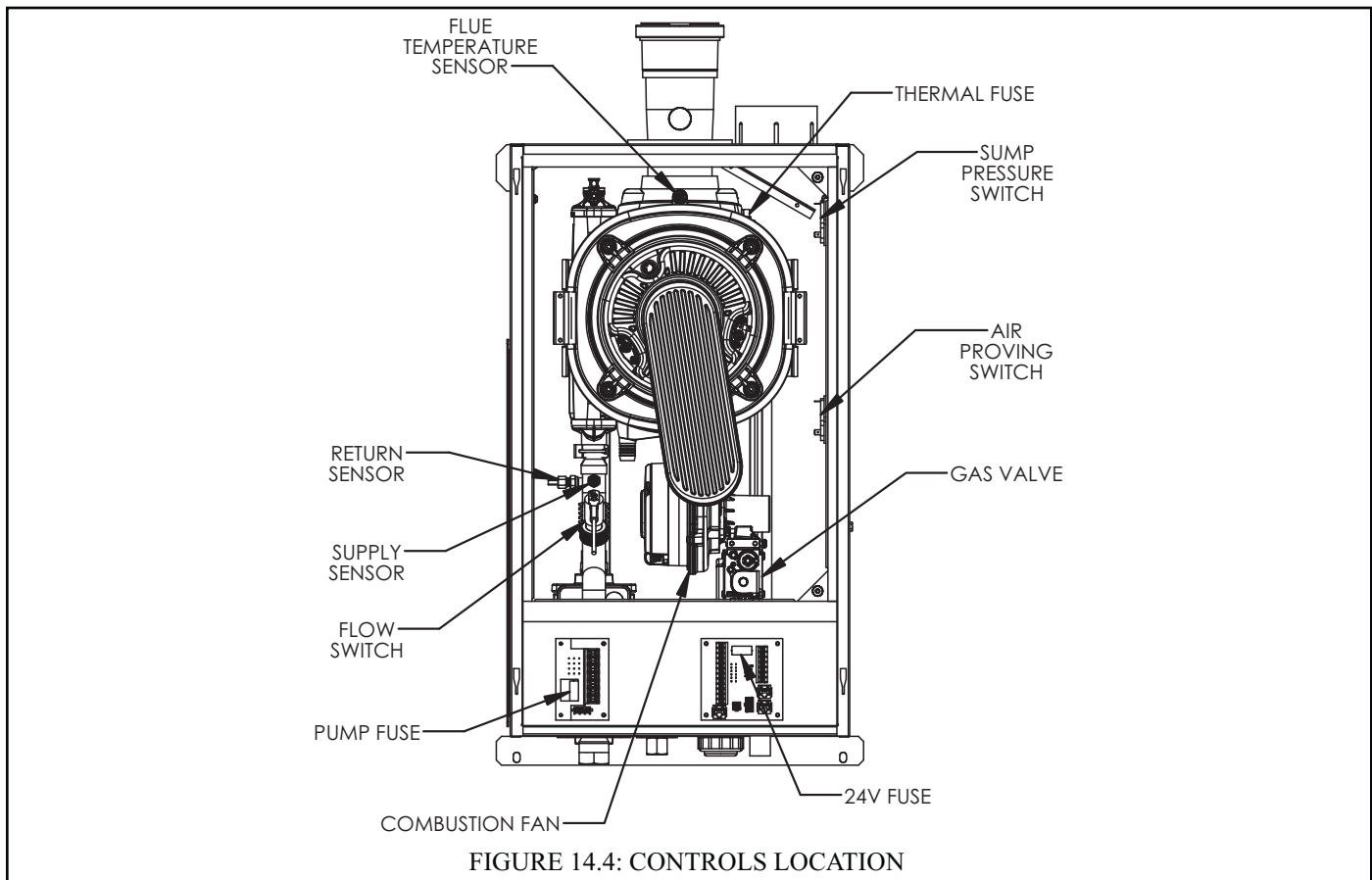

FIGURE 14.3: TROUBLESHOOTING BLANK OR UNREADABLE SCREEN



**Air Proving Switch (APS)** – This pressure switch is normally open and is connected to the outlet tapping on the gas valve as shown in Figure 14.5. During pre-purge, when the gas valve is closed, the IAS is monitoring the pressure drop across gas-air mixer (venturi for the 80-120, swirl plate on the 150 and 180). Greater air flow through the mixer causes this pressure reading to increase. The APS is calibrated to close when this pressure rises to 1.05 +/- 0.05" wc, which is a pressure at pre-purge corresponding to adequate air flow. After the gas valve opens, this pressure will drop very close to zero, regardless of the actual air flow rate through the boiler. For this reason, the APS is ignored after pre-purge. In the event that the burner fires continuously for one hour, the boiler control will recycle the burner to verify that the APS still closes and that adequate airflow is still present. If the APS opens, look for the following:

- Blockage in the vent or air intake system.
- Disconnected, loose or blocked APS tube.

**Flow Switch** – The paddle type flow switch is calibrated to close at a water flow rate of approximately 3.2GPM. This switch is intended to do two things:

- Prove that there is water in the boiler (no water means no flow at this switch)
- Prove that there is enough flow for the supply and return temperature sensors to accurately measure the water temperatures entering and exiting the heat exchanger.

The minimum flow rate required for all models is significantly above 3.2 GPM (Table 9.1). The boiler control verifies that there is adequate flow through the boiler by monitoring the temperature rise through the boiler; the flow switch merely assures that the measured rise is accurate. The boiler control starts to limit the firing rate when the temperature rise exceeds 53F and the boiler goes into a soft lockout if the rise reaches 63F.

If the flow switch does not close, look for the following:

- No water in the boiler
- Trapped air in the boiler or system - make sure that a steady stream of water exits the manual air vent shown in Figure 11.1 when it is opened.
- Valve closed in boiler loop piping
- Fouled Y strainer in boiler loop piping

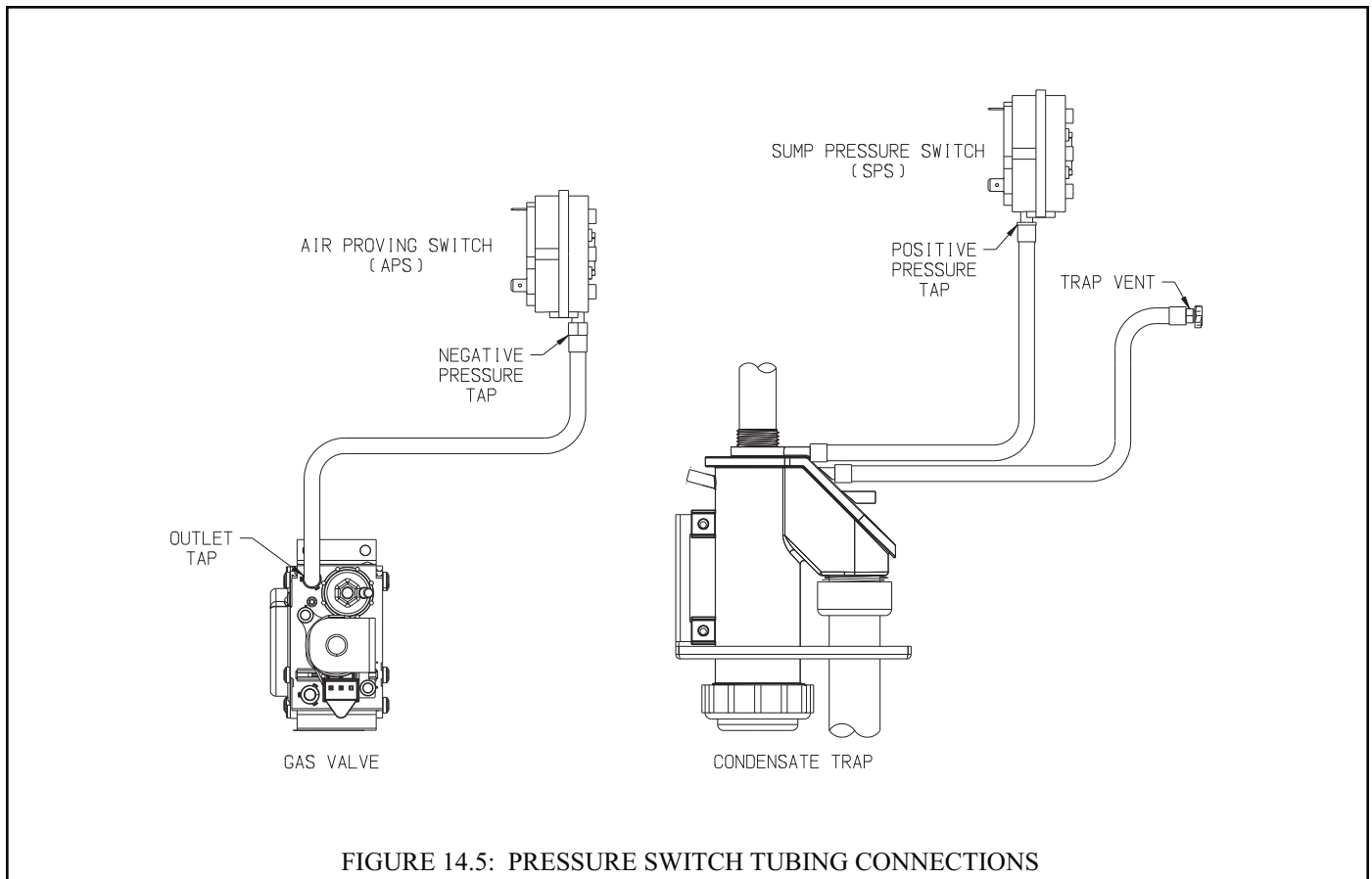

- Seized or disconnected boiler pump
- Blown Pump Fuse

**Supply Sensor** – The boiler control infers the supply temperature based on the resistance measured at the supply sensor. Table 14.6a shows this resistance as a function of water temperature. Because the control/supply sensor is used as the boiler’s water temperature limit control, there are actually two “thermistors” in the supply sensor wired in parallel (Figure 10.5). The control compares the resistances across these two thermistors and prevents boiler operation if there is a significant difference between the readings.

**Return Sensor** – The boiler control infers the return temperature based on the resistance measured across a single thermistor in the return sensor. Table 14.6a shows this resistance as a function of water temperature.

**Flue Temperature Sensor** – The boiler control infers the flue gas temperature based on the resistance measured at the flue temperature sensor. Table 14.6a shows this resistance as a function of flue temperature. There are actually two “thermistors” in the flue temperature sensor wired in parallel (Figure 10.5). The control compares the resistances across these two thermistors and prevents boiler operation if there is a significant difference between the readings.

**Outdoor Sensor** – The boiler control infers the outdoor temperature based on the resistance measured across a single thermistor in the outdoor sensor. Table 14.6b shows this resistance as a function of temperature.

**Condensate Trap** – The condensate trap allows condensate to leave the boiler while containing flue gasses. In the event that this trap becomes blocked, condensate will start to back up in the trap. To prevent a rising condensate level from backing up into the heat exchanger, both a ground wire and the flame rod wire are bonded to this trap in such a way that an abnormally high condensate level will conduct flame current directly to ground (Figure 10.5). The boiler control will interpret this as a loss of flame and enter a soft lockout. See Figures 7.35 or 13.3 for trap location.

**Table 14.6a: Supply, Return and Flue Temperature Sensor Temperature versus Resistance**

Temperature		Ohms of Resistance
°F	°C	
32	0	32624
50	10	19897
68	20	12493
77	25	10000
86	30	8056
104	40	5324
122	50	3599
140	60	2483
158	70	1748
176	80	1252
194	90	912
212	100	674
230	110	506
248	120	384

**Table 14.6b: Outdoor Air Temperature Sensor Temperature versus Resistance**

Outdoor Temperature		Ohms of Resistance
°F	°C	
-20	-28.9	106926
-10	-23.3	80485
0	-17.8	61246
10	-12.2	47092
20	-6.7	36519
30	-1.1	28558
40	4.4	22537
50	10.0	17926
60	15.6	14356
70	21.1	11578
76	24.4	10210
78	25.6	9795
80	26.7	9398
90	32.2	7672
100	37.8	6301
110	43.3	5203
120	48.9	4317

**Combustion Fan** – The combustion fan pushes air-fuel mixture into the burner and the speed of this blower determines the firing rate. There are two electrical connections at this fan:

- 120V Plug – Supplies 120VAC Power to the Fan
- Speed Control Plug - Delivers a PWM (speed control) signal from the boiler control to the fan. This plug also includes tachometer connections so that the boiler control can monitor the actual fan speed.

In the event that there is 120volts at the boiler, but no signal at the speed control plug, this fan will run at its maximum speed. Specific causes of this include:

- Disconnected speed control plug
- Blown 24V fuse.
- Loose J2 Plug
- Loose P8 plug (P8 is on back side of low voltage PCB)
- Loose L2 or L3 Plug

**Gas Valve** – The gas valve used on this boiler has either one or two 24VDC coils (the gas valve used on all boiler models is redundant). The gas valve output from the boiler control is 24VAC. A rectifier module is installed between the gas valve and the wiring harness on the 80, 100 and 120 models (Figure 11.4a). The rectifier is built into the gas valve plug itself on the 150 and 180.

## XV Parts

The following parts may be obtained from any Crown distributor. To find the closest Crown distributor, consult the area Crown representative or the factory at:

Crown Boiler Co.  
Customer Service  
P.O. Box 14818  
Philadelphia, PA 19134  
[www.crownboiler.com](http://www.crownboiler.com)

### NOTE

- **When replacing boiler pump, use only one recommended by Crown for use with this boiler.**
- **Grundfos 26-99 must always be set at speed 3.**
- **If pump must be replaced, do not remove return piping assembly (Key 16) from heat exchanger.**

KEY #	DESCRIPTION	QTY. OR CROWN PN	QUANTITY PER BOILER OR CROWN PART NUMBER				
			80	100	120	150	180
1	FIXING CLAMP BRACKET	2 EA	430003	430004	430005	430006	430006
2	HOLDING CLAMP	430002	2 EA	2 EA	2 EA	2 EA	2 EA
3	M4 x 6mm FIXING CLAMP SCREW	900240	4 EA	4 EA	4 EA	4 EA	4 EA
4	#10-32 X 1/2" THREAD CUTTING SCREW	900241	8 EA	8 EA	8 EA	8 EA	8 EA
5	BARE HEAT EXCHANGER	1 EA	430013	430014	430015	430016	430016
6	FLUE OUTLET GASKET	430017	1 EA	1 EA	1 EA	1 EA	1 EA
7	FLUE TEMPERATURE SENSOR	430120	1 EA	1 EA	1 EA	1 EA	1 EA
8	REFRACTORY TARGET WALL (WARNING: CONTAINS RCF)	430025	1 EA	1 EA	1 EA	1 EA	1 EA
9	BURNER DOOR GASKET	430020	1 EA	1 EA	1 EA	1 EA	1 EA
10	BURNER DOOR ASSEMBLY (WARNING: CONTAINS RCF)	1 EA	430021	430022	430023	430024	430024
11	FLAME ROD KIT	433030	1 EA	1 EA	1 EA	1 EA	1 EA
11A	FLAME ROD	430007	1 EA	1 EA	1 EA	1 EA	1 EA
11B	FLAME ROD GASKET	430008	1 EA	1 EA	1 EA	1 EA	1 EA
11C	M4 X 10mm ELECTRODE MOUNTING SCREW	900242	4 EA	4 EA	4 EA	4 EA	4 EA
12	IGNITION ELECTRODE KIT	433031	1 EA	1 EA	1 EA	1 EA	1 EA
12A	IGNITION ELECTRODE	430010	1 EA	1 EA	1 EA	1 EA	1 EA
12B	IGNITION ELECTRODE GASKET	430011	1 EA	1 EA	1 EA	1 EA	1 EA
13	M6 SERRATED FLANGE HEX BURNER DOOR NUT	900243	4 EA	4 EA	4 EA	4 EA	4 EA
14	EDPM O-RING (22mm ID x 2mm dia)	430053	2 EA	2 EA	2 EA	2 EA	2 EA
15	CONNECTION CLIP	430054	2 EA	2 EA	2 EA	2 EA	2 EA
16	INTERNAL RETURN PIPING ASSEMBLY	430052	1 EA	1 EA	1 EA	1 EA	1 EA
17	1" NPT CIRCULATOR FLANGE KIT	950151	1 EA	1 EA	1 EA	1 EA	1 EA
18	GASKET, CIRCULATOR FLANGE BULKHEAD	950152	1 EA	1 EA	1 EA	1 EA	1 EA
19	TACO 0013 CIRCULATOR	950161	1 EA	1 EA	1 EA	1 EA	1 EA
19	GRUNDFOS 26-99 CIRCULATOR (ALTERNATE)	95-201	1 EA	1 EA	1 EA	1 EA	1 EA
20	RETURN TEMPERATURE SENSOR	430125	1 EA	1 EA	1 EA	1 EA	1 EA
21	FLOW SWITCH WITH O-RING	430058	1 EA	1 EA	1 EA	1 EA	1 EA
21A	NBR O-RING (18mm ID x 2.5mm dia)	430095	1 EA	1 EA	1 EA	1 EA	1 EA
22	SUPPLY TEMPERATURE SENSOR	430122	1 EA	1 EA	1 EA	1 EA	1 EA
23	INTERNAL SUPPLY PIPING ASSEMBLY	1 EA	430055	430055	430056	430056	430056
24	GASKET, SUPPLY PIPING BULKHEAD	430057	1 EA	1 EA	1 EA	1 EA	1 EA



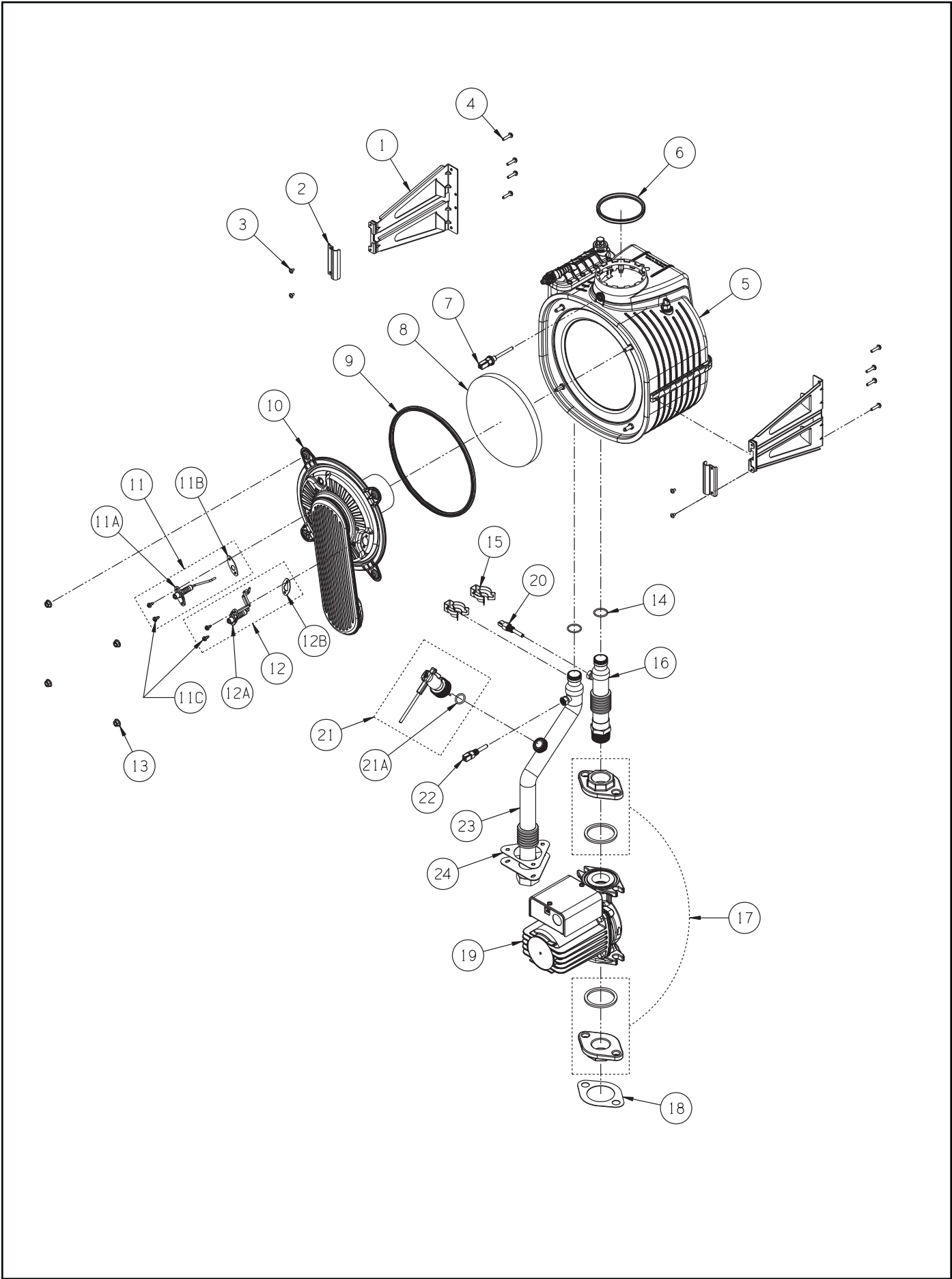

KEY #	DESCRIPTION	QTY. OR CROWN PN	QUANTITY PER BOILER OR CROWN PART NUMBER				
			80	100	120	150	180
27	M5 x 20mm SET SCREW	9000021	4 EA	4 EA	4 EA	4 EA	4 EA
28	BLOWER OUTLET GASKET	430030	1 EA	1 EA	1 EA	1 EA	1 EA
29	M5 LOCKNUT	900003	4 EA	4 EA	4 EA	4 EA	4 EA
30	CSST GAS LINE ASSEMBLY	430037	1 EA	1 EA	1 EA	1 EA	1 EA
31	CSST GAS LINE FLANGE GASKET	430038	1 EA	1 EA	1 EA	1 EA	1 EA
32	AIR PROVING PRESSURE SWITCH	430009	1 EA	1 EA	1 EA	1 EA	1 EA
33	SILCONE TUBING (5/16" ID)	430060	1 EA	1 EA	1 EA	1 EA	1 EA
34	CSST x 1/2" NPT ADAPTER	230715	1 EA	1 EA	1 EA	1 EA	1 EA
35	GAS VALVE FLANGE KIT	3507326	1 EA	1 EA	1 EA	1 EA	1 EA
36	BLOWER, NRV118 WITH #533 VENTURI	1 EA	430032	430032			
36	BLOWER, NRV118 WITH #532 VENTURI	1 EA			430033		
36	BLOWER, RG148/1200-3633	1 EA				430034	430034
37	RUBBER COUPLING	430035	1 EA	1 EA	1 EA		
38	GAS ORIFICE, 5.25 mm	1 EA	3507332				
38	GAS ORIFICE, 5.00 mm	1 EA		3507333			
38	GAS ORIFICE, 6.50 mm	1 EA			3507334		
38	GAS ORIFICE, 7.00 mm	1 EA				3507339	3507339
39	GAS VALVE, GB-ND 055 E01 S00	1 EA	3507370	3507370	3507370		
39	GAS VALVE, GB-WND 055 D01 S00 LH	1 EA				3507375	3507375
40	RECTIFIER MODULE	3507371	1 EA	1 EA	1 EA		
41	RECTIFIER PLUG w/ M4 X 30mm CONNECTOR SCREW	3507372				1 EA	1 EA
42	BLOWER INLET SHROUD ASSEMBLY WITH 9.0 mm RED SWIRLPLATE	1 EA				430045	
42	BLOWER INLET SHROUD ASSEMBLY WITH 12.0 mm GRAY SWIRLPLATE	1 EA					430046
43	M4 x 8mm TORX HEAD SCREW	900244				4 EA	4 EA
44	M4 x 25mm TRI-LOBULAR TORX SELF THREADING SCREW	3 EA				900245	
44	M4 x 29mm TRI-LOBULAR TORX SELF THREADING SCREW	3 EA					900246
45	ATTENUATOR ASSEMBLY	430040				1 EA	1 EA
46	#8 x 18 SHEET METAL SCREW (1-1/2")	900247				1 EA	1 EA
47	1/2" NPT 90° STREET ELBOW	950056				1 EA	1 EA
48	M5 X 16mm TORX HEAD SCREW	900016	2 EA	2 EA	2 EA		

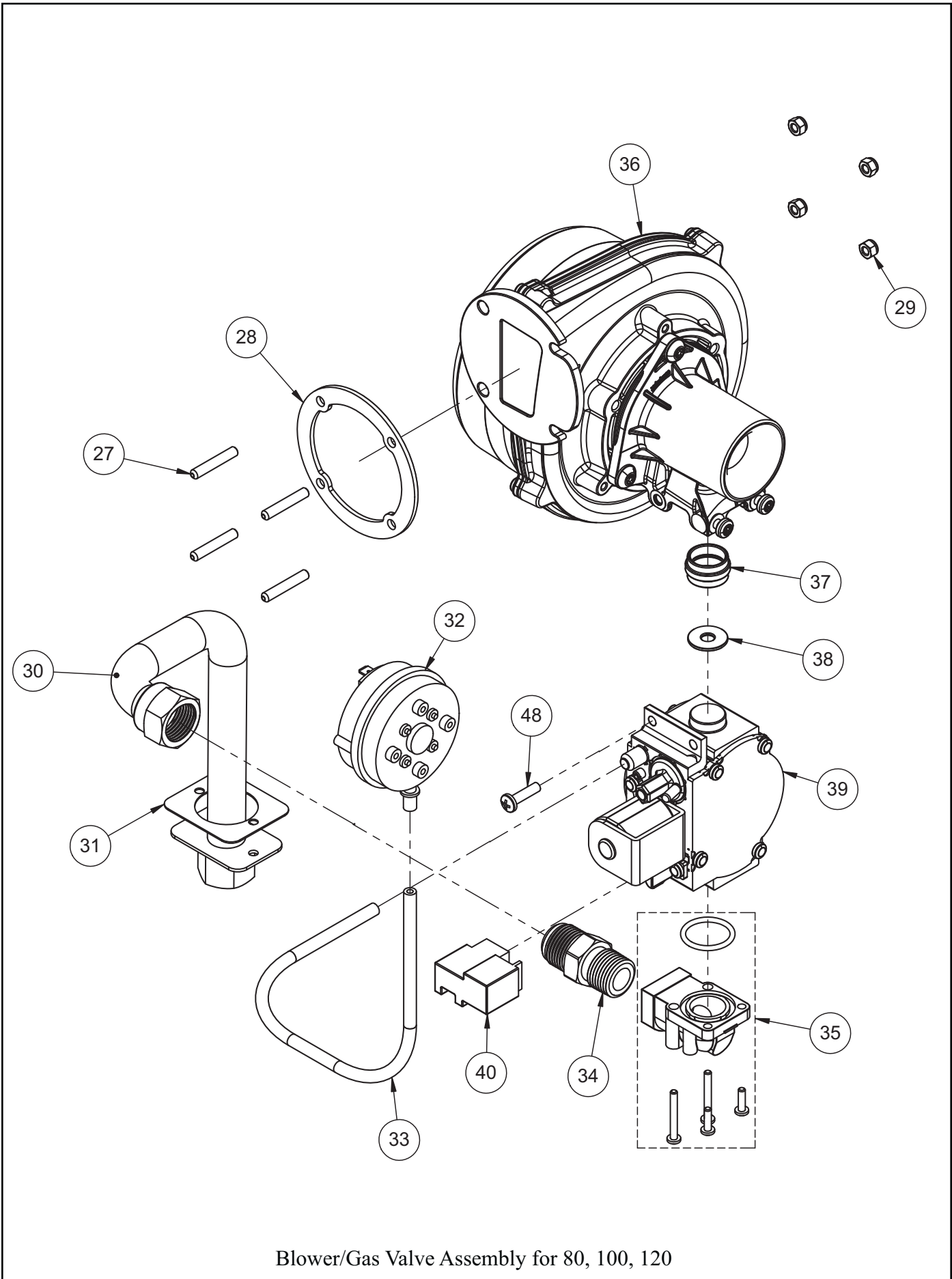

Blower/Gas Valve Assembly for 80, 100, 120

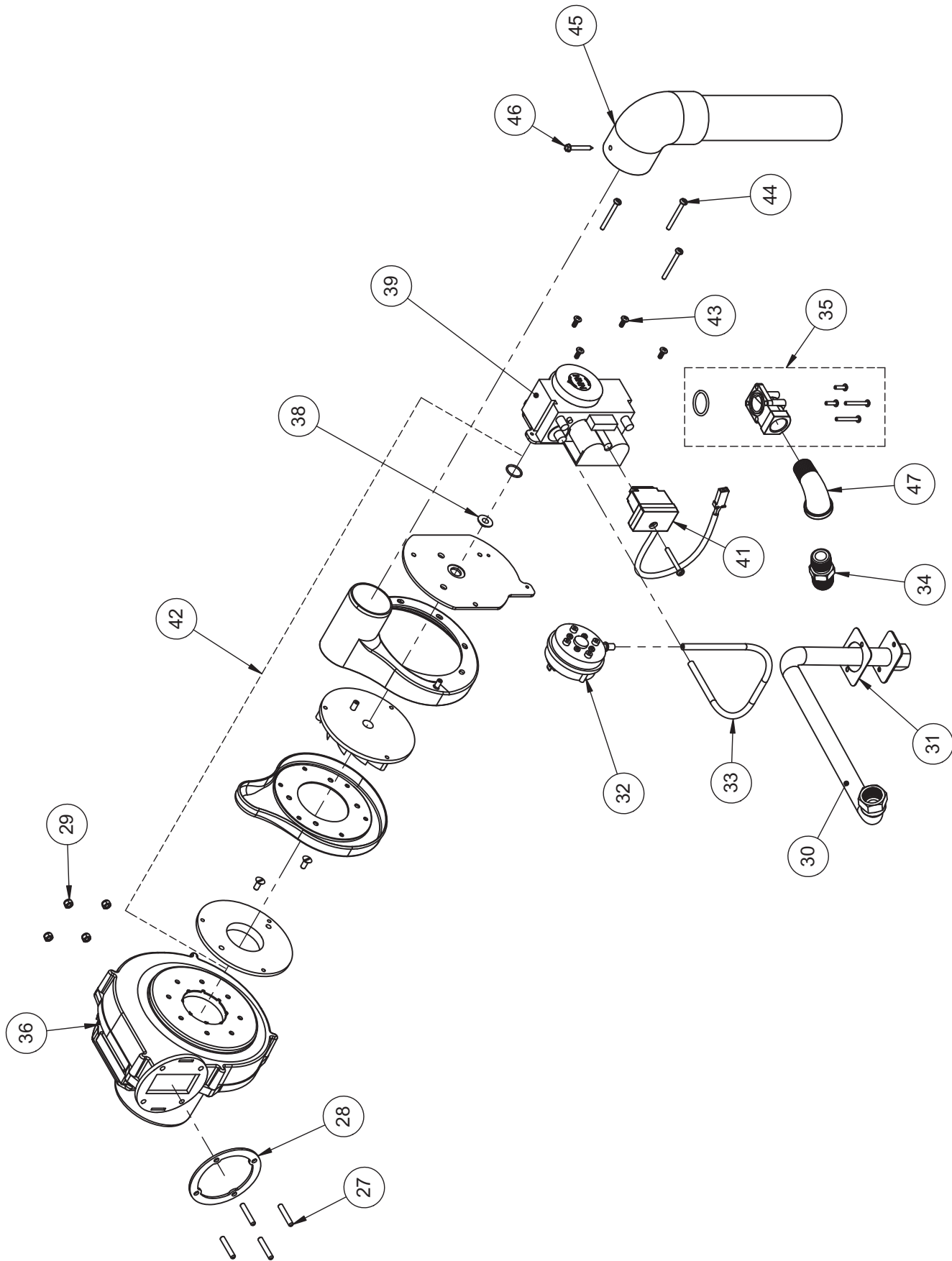

Blower/Gas Valve Assembly for 150, 180

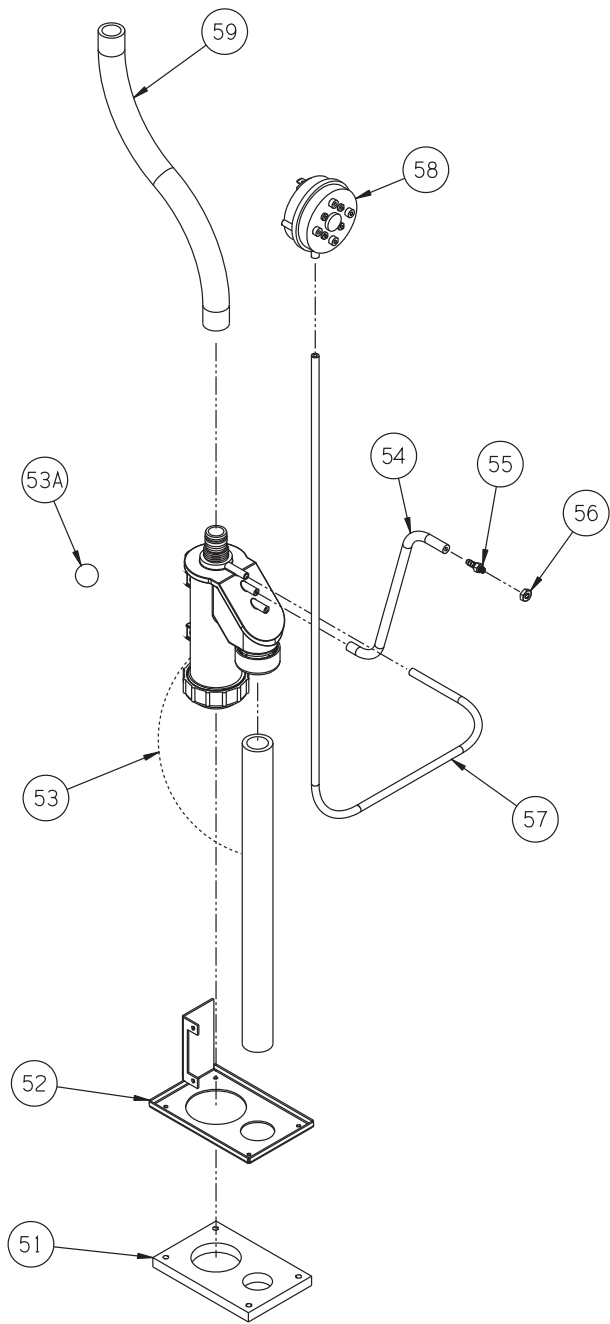

KEY #	DESCRIPTION	QTY. OR CROWN PN	QUANTITY PER BOILER OR CROWN PART NUMBER				
			80	100	120	150	180
51	GASKET, CONDENSATE TRAP	430105	1 EA	1 EA	1 EA	1 EA	1 EA
52	CONDENSATE TRAP BRACKET	430106	1 EA	1 EA	1 EA	1 EA	1 EA
53	CONDENSATE TRAP (INCLUDES 53A)	430100	1 EA	1 EA	1 EA	1 EA	1 EA
53A	CONDENSATE TRAP BALL	430101	1 EA	1 EA	1 EA	1 EA	1 EA
54	SILCONE TUBING (3/16" ID)	430061	1 EA	1 EA	1 EA	1 EA	1 EA
55	3/16" HOSE BARB FITTING	430065	1 EA	1 EA	1 EA	1 EA	1 EA
56	10-32 HEX FLANGE NUT	900248	1 EA	1 EA	1 EA	1 EA	1 EA
57	SILCONE TUBING (3/16" ID)	430062	1 EA	1 EA	1 EA	1 EA	1 EA
58	SUMP PRESSURE SWITCH	430109	1 EA	1 EA	1 EA	1 EA	1 EA
59	SILCONE TUBING (3/4" ID)	430063	1 EA	1 EA	1 EA	1 EA	1 EA
65	GASKET, SHORT, VESTIBULE FRAME	430400	2 EA	2 EA	2 EA	2 EA	2 EA
66	GASKET, LONG, VESTIBULE FRAME/CONTROL PANEL	430402	2 EA	2 EA	2 EA	2 EA	2 EA
67	5/16 OD x 1/4" SPACER	960054	8 EA	8 EA	8 EA	8 EA	8 EA
68	GASKET, LOW VOLTAGE PCB	430404	1 EA	1 EA	1 EA	1 EA	1 EA
69	LOW VOLTAGE PRINTED CIRCUIT BOARD	3503042	1 EA	1 EA	1 EA	1 EA	1 EA
70	GASKET, LINE VOLTAGE PCB	430406	1 EA	1 EA	1 EA	1 EA	1 EA
71	LINE VOLTAGE PRINTED CIRCUIT BOARD	3503043	1 EA	1 EA	1 EA	1 EA	1 EA
72	PCB INSULATOR	430408	1 EA	1 EA	1 EA	1 EA	1 EA
73	#8-18 x 3/4" SCREW	900249	8 EA	8 EA	8 EA	8 EA	8 EA
74	#8-18 X 1/2" SELF TAPPING SCREW	900250	1 EA	1 EA	1 EA	1 EA	1 EA
75	TRANSFORMER	3502430	1 EA	1 EA	1 EA	1 EA	1 EA
76	HONEYWELL R7910B BOILER CONTROL KIT	433022	1 EA	1 EA	1 EA	1 EA	1 EA
77	THUMB SCREW, 8-32 x 13/32"	900251	2 EA	2 EA	2 EA	2 EA	2 EA
78	GASKET, WIRE PARTITION	430412	4 EA	4 EA	4 EA	4 EA	4 EA
79	#8-18 x 1/2" SELF TAPPING SCREW	900250	8 EA	8 EA	8 EA	8 EA	8 EA
80	PROGAMMED DISPLAY KIT	433060	1 EA	1 EA	1 EA	1 EA	1 EA
81	8-18 x 1/2" SELF TAPPING SCREW	900250	6 EA	6 EA	6 EA	6 EA	6 EA
82	CONTROL PANEL GASKET	430415	4 EA	4 EA	4 EA	4 EA	4 EA
83	GASKET, CABLE HOLDER	430416	3 EA	3 EA	3 EA	3 EA	3 EA
*	CABLE HOLDER ANCHOR MOUNT	430339	3 EA	3 EA	3 EA	3 EA	3 EA

\* NOT SHOWN

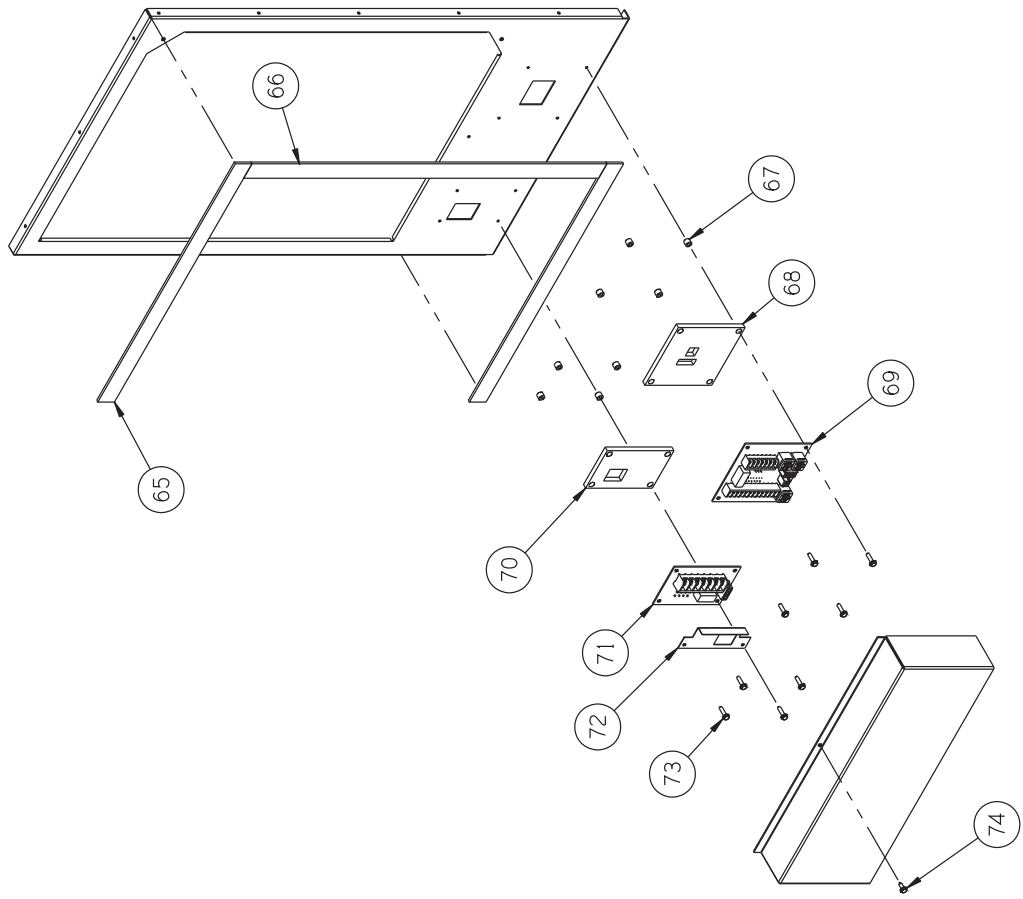

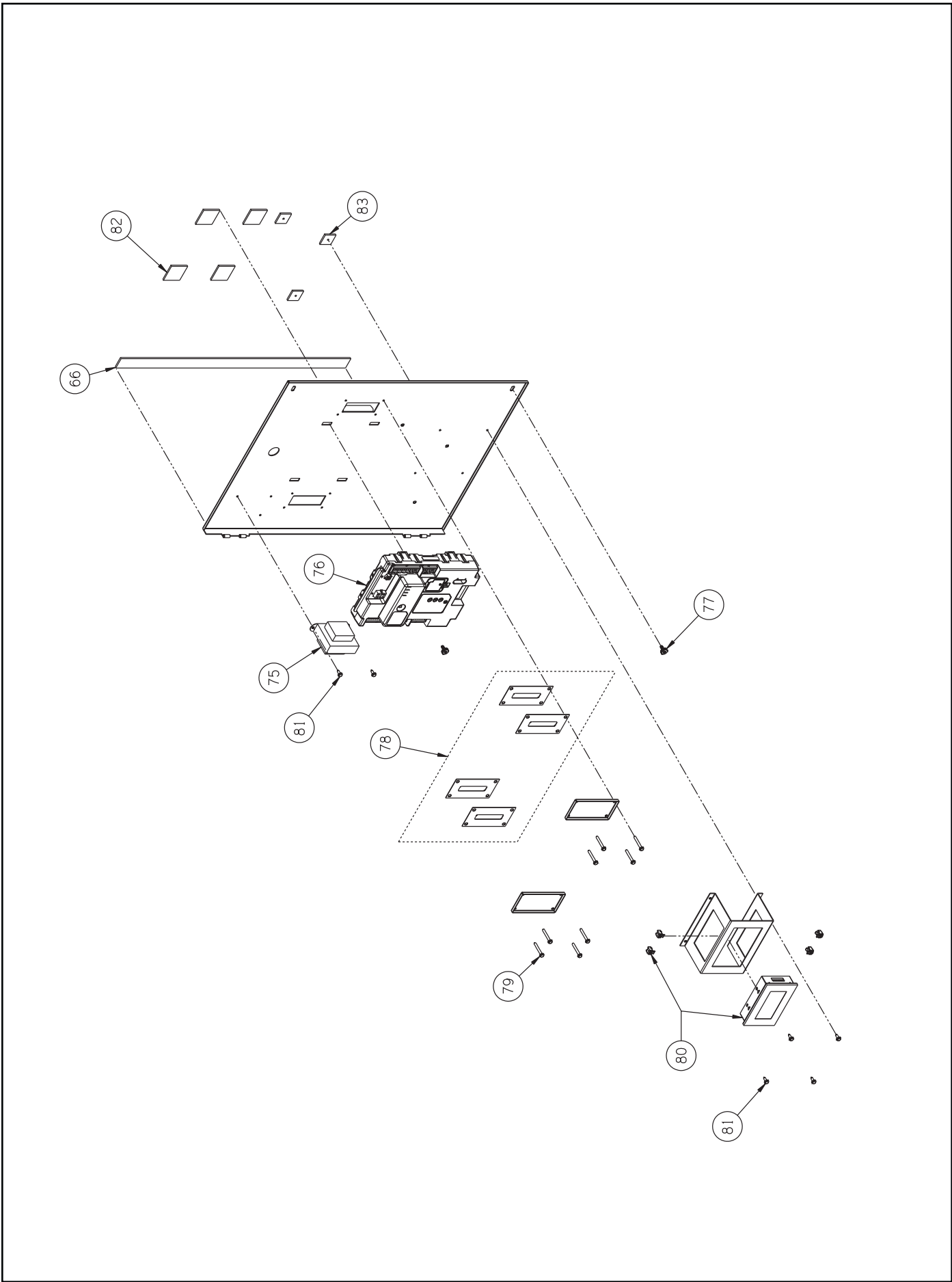



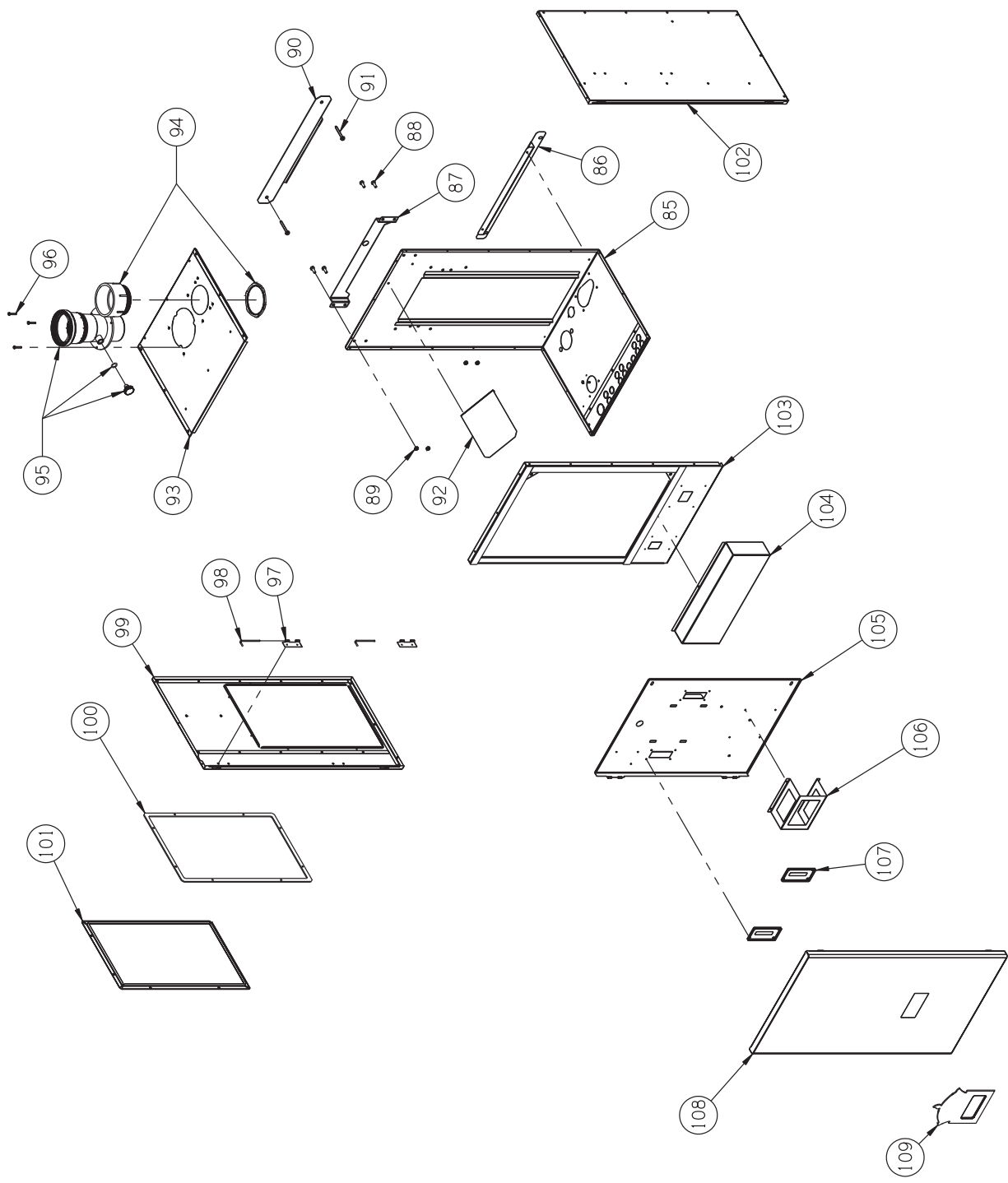

KEY #	DESCRIPTION	QTY. OR CROWN PN	QUANTITY PER BOILER OR CROWN PART NUMBER				
			80	100	120	150	180
85	BASE-REAR PANEL	1 EA	430303	430303	430303	430304	430304
86	BOTTOM SECURING BRACKET	430420	1 EA	1 EA	1 EA	1 EA	1 EA
87	HANGING BRACKET, BOILER	430435	1 EA	1 EA	1 EA	1 EA	1 EA
88	1/4-20 X 1/2" CAP SCREW	900720	4 EA	4 EA	4 EA	4 EA	4 EA
89	1/4-20 LOCKNUT	900721	4 EA	4 EA	4 EA	4 EA	4 EA
90	HANGING BRACKET, WALL	430410	1 EA	1 EA	1 EA	1 EA	1 EA
91	5/16 X 2" LAG SCREW	900760	4 EA	4 EA	4 EA	4 EA	4 EA
*	5/16" FLAT WASHER	900102	4 EA	4 EA	4 EA	4 EA	4 EA
92	AIR INTAKE SHIELD BRACKET	430302	1 EA	1 EA	1 EA	1 EA	1 EA
93	TOP PANEL	1 EA	430323	430323	430323	430324	430324
94	3" PVC INTAKE COUPLING WITH LOCKNUT	430800	1 EA	1 EA	1 EA	1 EA	1 EA
95	VENT ADAPTER	430801	1 EA	1 EA	1 EA	1 EA	1 EA
*	VENT ADAPTER GASKET	430802	1 EA	1 EA	1 EA	1 EA	1 EA
96	#8-18 X 1/2" SCREW	900256	3 EA	3 EA	3 EA	3 EA	3 EA
97	CONTROL HINGE BRACKET	430332	2 EA	2 EA	2 EA	2 EA	2 EA
98	HINGE PIN	430333	2 EA	2 EA	2 EA	2 EA	2 EA
99	LEFT SIDE PANEL	1 EA	430301	430301	430301	4303015	4303015
100	ACCESS PANEL GASKET	430306	1 EA	1 EA	1 EA	1 EA	1 EA
101	ACCESS PANEL	430305	1 EA	1 EA	1 EA	1 EA	1 EA
102	RIGHT SIDE PANEL	1 EA	430300	430300	430300	4303005	4303005
103	VESTIBULE FRAME	430331	1 EA	1 EA	1 EA	1 EA	1 EA
104	WIRING ENCLOSURE COVER	430334	1 EA	1 EA	1 EA	1 EA	1 EA
105	CONTROL PANEL	430330	1 EA	1 EA	1 EA	1 EA	1 EA
106	DISPLAY MOUNTING BRACKET	430337	1 EA	1 EA	1 EA	1 EA	1 EA
107	WIRE COVER BRACKET	430338	2 EA	2 EA	2 EA	2 EA	2 EA
108	FRONT PANEL	430313	1 EA	1 EA	1 EA	1 EA	1 EA
109	PHANTOM LOGO PLATE	430050	1 EA	1 EA	1 EA	1 EA	1 EA
115	1"NPT X 2-1/2" NIPPLE	950123	1 EA	1 EA	1 EA	1 EA	1 EA
116	1" NPT TEE	950111	1 EA	1 EA	1 EA	1 EA	1 EA
117	3/4" NPT BOILER DRAIN VALVE	95-041	1 EA	1 EA	1 EA	1 EA	1 EA
118	1"NPT x 2" NIPPLE	950122	1 EA	1 EA	1 EA	1 EA	1 EA
119	1" NPT TEE WITH SIDE OUTLET	950112	1 EA	1 EA	1 EA	1 EA	1 EA
120	1" x 1/4" NPT HEX REDUCING BUSHING	950115	1 EA	1 EA	1 EA	1 EA	1 EA
121	TEMPERATURE/PRESSURE GAUGE	95-038	1 EA	1 EA	1 EA	1 EA	1 EA
122	1" x 3/4" NPT HEX REDUCING BUSHING	950113	2 EA	2 EA	2 EA	2 EA	2 EA
123	3/4" NPT X 4" NIPPLE	950003	1 EA	1 EA	1 EA	1 EA	1 EA
124	3/4" NPT 90° ELBOW	95-057	1 EA	1 EA	1 EA	1 EA	1 EA
125	3/4" NPT X 30" NIPPLE	950006	1 EA	1 EA	1 EA	1 EA	1 EA
126	30 psi RELIEF VALVE	95-040	1 EA	1 EA	1 EA	1 EA	1 EA

\* NOT SHOWN

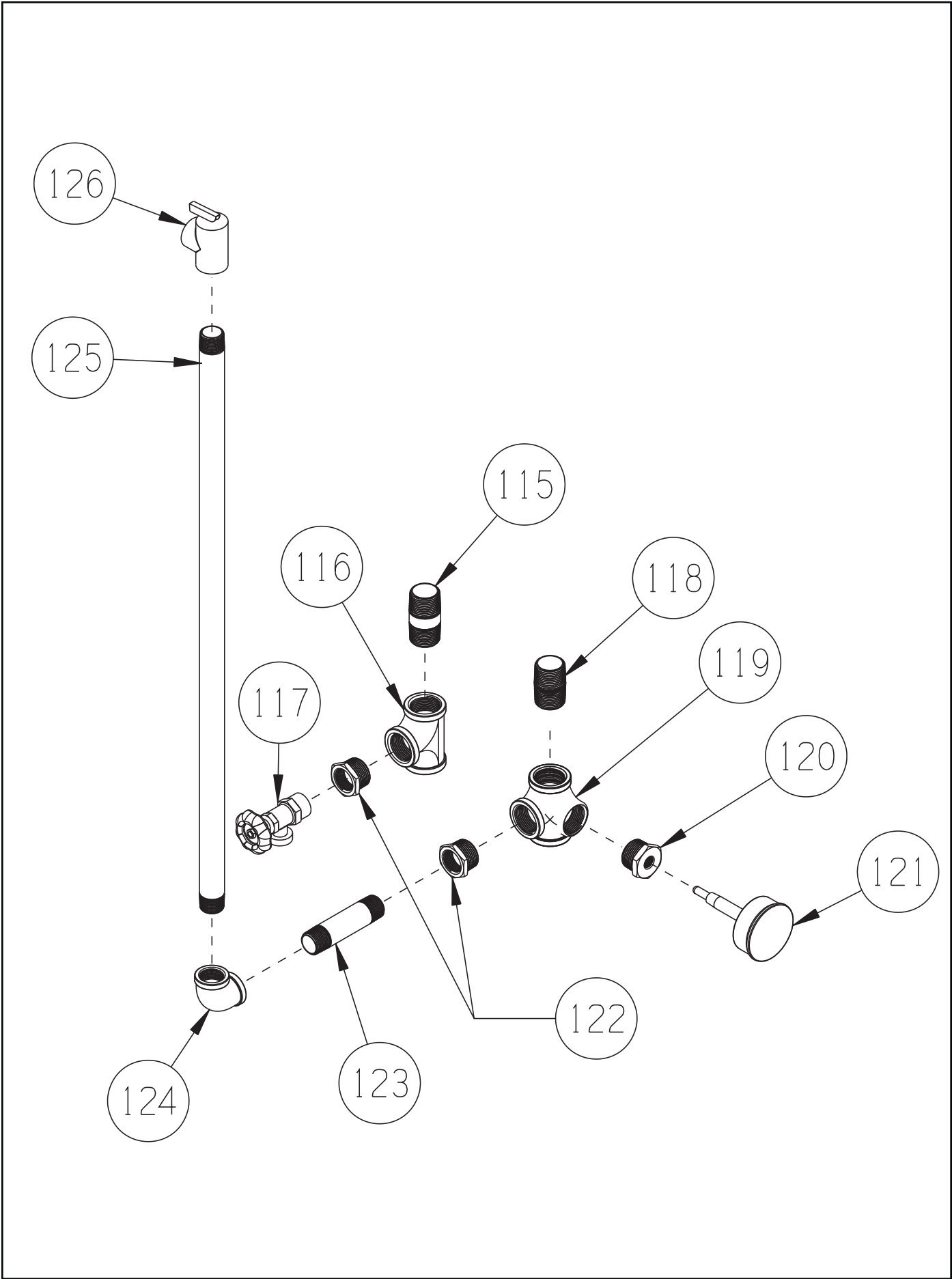

KEY #	DESCRIPTION	QTY. OR CROWN PN	QUANTITY PER BOILER OR CROWN PART NUMBER				
			80	100	120	150	180
130	3" STAINLESS STEEL RODENT SCREEN	230833	2 EA	2 EA	2 EA	2 EA	2 EA
131	3" X 30" SCHEDULE 40 CPVC PIPE	230823	1 EA	1 EA	1 EA	1 EA	1 EA
132	3" SCHEDULE 80 CPVC 90° ELBOW	230813	1 EA	1 EA	1 EA	1 EA	1 EA
133	3" PVC COUPLING	430853	1 EA	1 EA	1 EA	1 EA	1 EA
134	3" PVC LONG SWEEP 90° ELBOW	430803	1 EA	1 EA	1 EA	1 EA	1 EA
140	LOW VOLTAGE / COMMUNICATION WIRING HARNESS	9604300	1 EA	1 EA	1 EA	1 EA	1 EA
141	HIGH VOLTAGE / IGNITOR WIRING HARNESS	9604301	1 EA	1 EA	1 EA </td <td>1 EA</td> <td>1 EA</td>	1 EA	1 EA
142	CONDENSATE TRAP/FLAME SENSE WIRE HARNESS	9604302	1 EA	1 EA	1 EA	1 EA	1 EA
143	CONDENSATE TRAP/GROUND WIRE HARNESS	9604303	1 EA	1 EA	1 EA	1 EA	1 EA
144	IGNITION CABLE WIRE HARNESS	9604304	1 EA	1 EA	1 EA	1 EA	1 EA
145	CIRCULATOR PIGTAIL WIRE HARNESS	9604305	1 EA	1 EA	1 EA	1 EA	1 EA
*	LWCO JUMPER	9604306	1 EA	1 EA	1 EA	1 EA	1 EA
*	EXTERNAL LIMIT JUMPER	9604307	1 EA	1 EA	1 EA	1 EA	1 EA
*	GT02L PCB ADAPTER	9601752	1 EA	1 EA	1 EA	1 EA	1 EA
*	1.6A FUSE	9604308	1 EA	1 EA	1 EA	1 EA	1 EA
*	6.3A FUSE	9604309	1 EA	1 EA	1 EA	1 EA	1 EA
*	OUTDOOR TEMPERATURE SENSOR	350082	1 EA	1 EA	1 EA	1 EA	1 EA
*	USERS MANUAL	980126	1 EA	1 EA	1 EA	1 EA	1 EA
*	INSTALLATION AND OPERATION MANUAL	980125	1 EA	1 EA	1 EA	1 EA	1 EA

\* NOT SHOWN

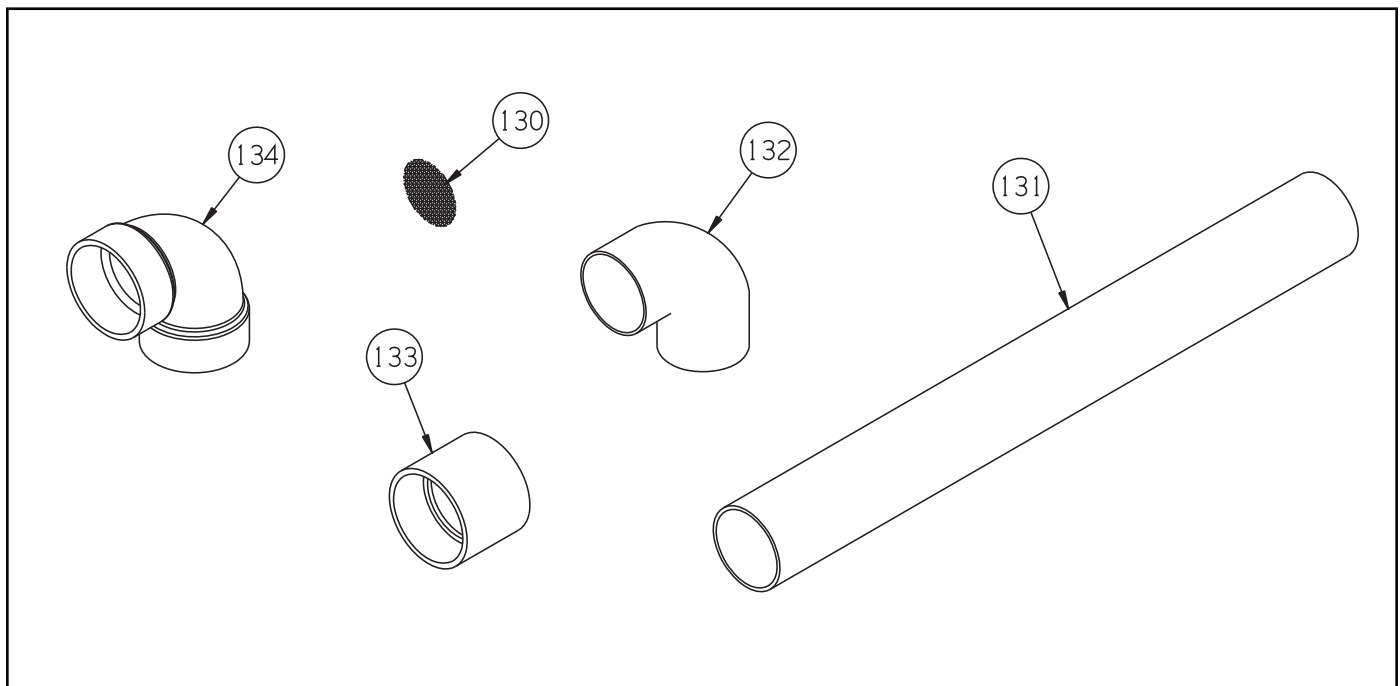

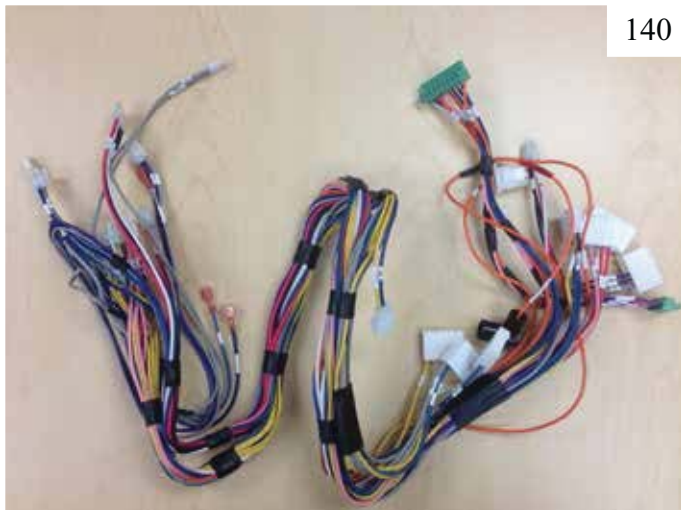

140



141



142



143



144



145

## Appendix A: Instructions for Conversion of This Boiler for Use with LP Gas and/or Altitudes above 2000ft



### DANGER

These instructions include a procedure for adjusting the air-fuel mixture on this boiler. This procedure requires a combustion analyzer to measure the CO<sub>2</sub> and Carbon Monoxide (CO) levels in flue gas. Adjusting the air-fuel mixture without a proper combustion analyzer could result in unreliable boiler operation, personal injury, or death due to carbon monoxide poisoning.



### WARNING

- **PHNTM080, PHNTM180** - Do not attempt to convert PHNTM080 for use with LP gas at altitudes above 2000ft. Also, do not attempt to convert PHNTM180 for use with LP gas at altitudes above 7800ft. Attempts to do so may result in unreliable operation, property damage, personal injury, or loss of life due to carbon monoxide (CO) poisoning.
- **LP CONVERSIONS** - This conversion kit shall be installed by a qualified service agency in accordance with the manufacturer's instructions and all applicable codes and requirements of the authority having jurisdiction. If the information in these instructions is not followed exactly, a fire, an explosion or production of carbon monoxide may result causing property damage, personal injury, or loss of life. The qualified service agency is responsible for proper installation of this kit. The installation is not proper and complete until the operation of the converted appliance is checked as specified in the manufacturer's instructions supplied with the kit.
- **ALTITUDE CONVERSIONS** - This conversion shall be performed by a qualified service agency in accordance with these instructions and all applicable codes and requirements of the authority having jurisdiction. If the information in these instructions is not followed exactly, unreliable operation, property damage or production of carbon monoxide may result causing property damage, personal injury, or loss of life. The installation is not proper and complete until the operation of the converted boiler is checked as specified in these instructions.

### NOTICE

- **IN CANADA** - Contact Provincial authority having jurisdiction for installations that are more than 4500 feet (1350 m) above sea level.
- Model numbers ending in "A" cannot be converted for use at altitudes above 2000ft. For example:  
PHTM180HNT1SU**A** CANNOT be converted for use above 2000ft.  
PHTM180HNT1SU**B** CAN be converted for use above 2000ft.

All Phantom boilers are factory configured for use on Natural gas at altitudes below 2000 feet. Perform the steps listed in these instructions if either, or both, of the following are true:

- Boiler is to be used with LP gas
- Boiler is to be installed at an altitude above 2000ft.

**Follow steps 1-13 below in the order they are presented.** Steps applying to only one type of conversion (LP or altitude) may be skipped if that type of conversion is not being performed.

- 1) If not already done, install the boiler in accordance with this manual, following all instructions in Part XI (Start-up and Check-out) up to Step 10.
- 2) LP CONVERSIONS ONLY – Set the throttle to its preliminary setting for LP. To do this:
  - a. Turn the throttle (Figure A.1) clockwise until it stops (several full turns).
  - b. Turn throttle counter-clockwise the exact number of turns shown in Table A.2.
- 3) ALTITUDE CONVERSIONS ONLY – Control system must be set to permit operation at higher fan speeds than those used at sea level. This is changed in the ALTITUDE MENU (Figure A.3). To change altitude setting in control:
  - a. From the home screen, press MENU
  - b. From the main menu, press CONFIGURE
  - c. When prompted for a password. Use the “+1” button to raise the password to 5, then press SUBMIT. If you accidentally raise the password above 5, press EXIT to return to the main menu and start over.
  - d. Once the password is accepted, review the WARNING screen and press ACCEPT to reach the configuration menu.
  - e. At the configuration menu, press ADVANCED to reach the advanced configuration menu.
  - f. Press ALTITUDE. Review the WARNING screen that follows, and press ACCEPT to reach the altitude screen.
  - g. Press the altitude shown to advance to the appropriate altitude (Figure A.3). Four altitude ranges can be selected:
    - 0 - 2000ft (Default)
    - 2001 - 4500ft
    - 4501 - 7800ft
    - 7801 - 10200ftWhere the installation altitude is very close to one of these breakpoints, use the lower range.
  - h. Press SET to select the appropriate configuration. Control has accepted this change when SET and the altitude stops flashing.
  - i. Return to the HOME screen and verify that the appropriate altitude range (in kft) is shown in the lower right corner of the screen (Fig A.3)
- 4) Attempt to start the boiler using the lighting instructions located on Page 90. If the boiler does not light on the first try for ignition, allow to boiler to make at least four more attempts to light. If boiler still does not light, turn the throttle counterclockwise in 1/8 turn increments, allowing the boiler to make at least four tries for ignition at each setting, until the boiler lights.
- 5) After the burner lights, force the burner to high fire by entering the Settings Menu, and selecting Manual Input, then High Fire Hold as described in Part XI (start-up and checkout). Allow the boiler to operate for approximately 5 minutes before taking combustion readings. Note: that after 12 minutes, 45 seconds the boiler is automatically released from high fire hold. The boiler will also be released from manual input if the user manually navigates back to the home screen.
- 6) Perform a combustion test, sampling flue products from the tap in the front of the vent adaptor.
- 7) While the burner is at high fire adjust the throttle as needed to obtain the CO<sub>2</sub> settings shown in the Table A.4:
  - To reduce the CO<sub>2</sub> (increase the O<sub>2</sub>) turn the throttle clockwise
  - To increase the CO<sub>2</sub> (reduce the O<sub>2</sub>) turn the throttle counter-clockwise

Make adjustments in increments of 1/8 to 1/4 turn and allow the boiler at least a minute to respond to each adjustment before making another. In general, the CO level will be at its lowest somewhere in the CO<sub>2</sub> range shown in this table. Consult



## WARNING

- **The throttle adjustments shown in Table A.2 are approximate. The final throttle setting must be found using a combustion analyzer. Leaving the boiler in operation with a CO level in excess of 200PPM air-free could result in injury or death from carbon monoxide poisoning. Leaving the boiler in operation with a CO<sub>2</sub> level outside of the range shown in Table A.4 could also result in injury or death from carbon monoxide poisoning, even if the boiler is operating at an air-free CO level below 200PPM during this adjustment procedure.**
- **If the throttle is very far out of adjustment on the “rich” (counter-clockwise) side, the boiler burner may be running at 0% excess air or even with air deficiency. Operating the boiler in this condition may cause property damage, personal injury or loss of life. Under these conditions most combustion analyzers used in the field will show 0% O<sub>2</sub> and a very high (well over 1000 ppm) CO. Combustion readings will also appear to be unresponsive to throttle adjustment. If the boiler appears to be operating under this condition, turn the throttle screw clockwise until the flame lengthens significantly and is mostly blue. Then, slowly turn the throttle counter-clockwise, using a combustion analyzer to achieve the required CO<sub>2</sub> as described in Step 7.**

factory if it is not possible to reduce the CO level below 200PPM air free within the range of CO<sub>2</sub>s shown for the fuel and altitude at which the boiler is being used.

- 8) Replace the screw cap in the vent adapter when combustion testing is complete.
- 9) Cycle boiler at least five times at the final throttle setting to ensure burner ignites without delay and without noise.
- 10) Verify that the gas inlet pressure is between the following shown in Table A.5 with all gas appliances (including the converted boiler) both on and off.
- 11) LP CONVERSIONS ONLY - A sheet of yellow labels is provided in the envelope with this manual for boilers converted from natural to LP gas. Select the model from this sheet of labels and apply them as follows:
  - a. Apply the “Rating Plate Label” adjacent to the rating plate.
  - b. Apply the “Gas Valve Label” to a conspicuous area on the gas valve.
  - c. Apply the “Boiler Conversion Label” to a conspicuous surface on, or adjacent to, the outer boiler jacket. Fill in the date of the conversion and the name and address of the company making the conversion with a permanent marker.
- 12) Refer to the “Start-up and Checkout” section of the boiler installation manual and perform any checks not already completed.
- 13) Higher altitudes cause the boiler input and output to drop by between 0% and 2.4% per thousand feet, depending on model, fuel, and altitude. Consult factory for details.



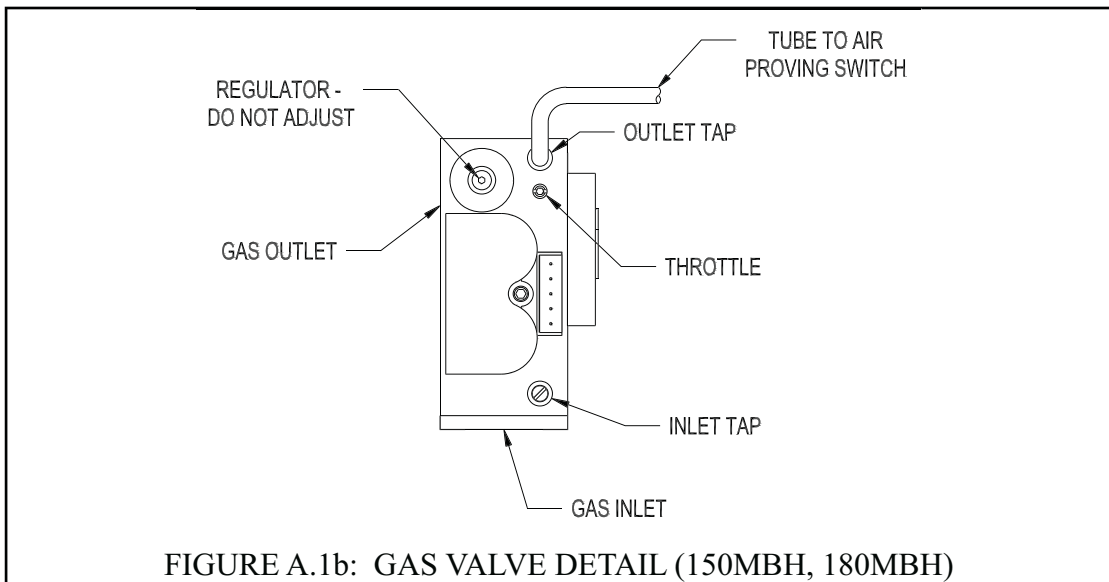
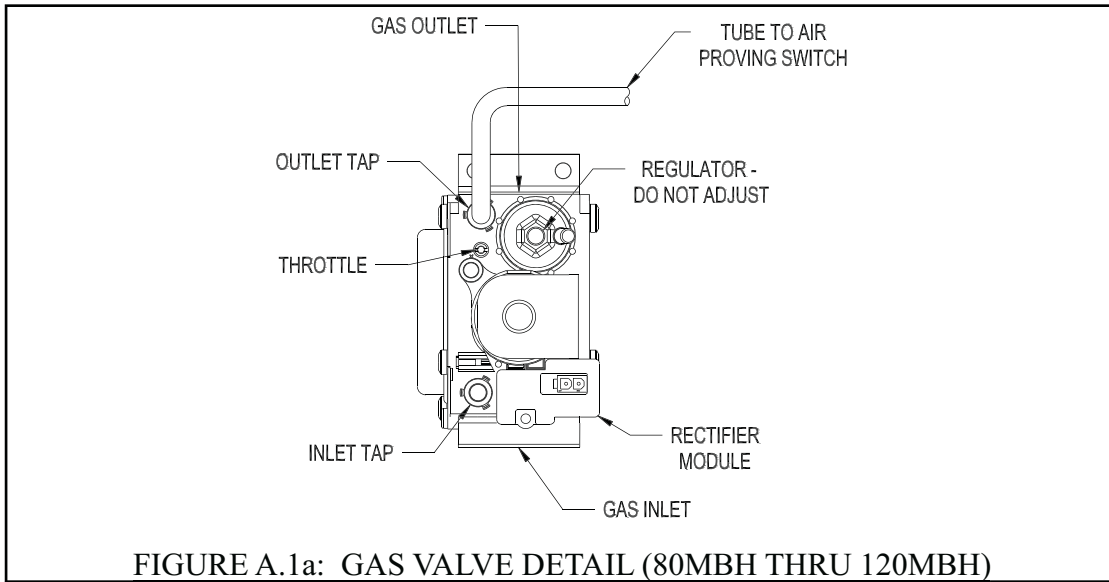

**TABLE A.2: STARTING NUMBER OF THROTTLE TURNS FOR CONVERSION TO LP GAS**

MODEL	# COUNTERCLOCKWISE TURNS (FROM FULLY CLOSED)
080	3-3/4
100	3
120	4
150	5-3/4
180	6-1/2

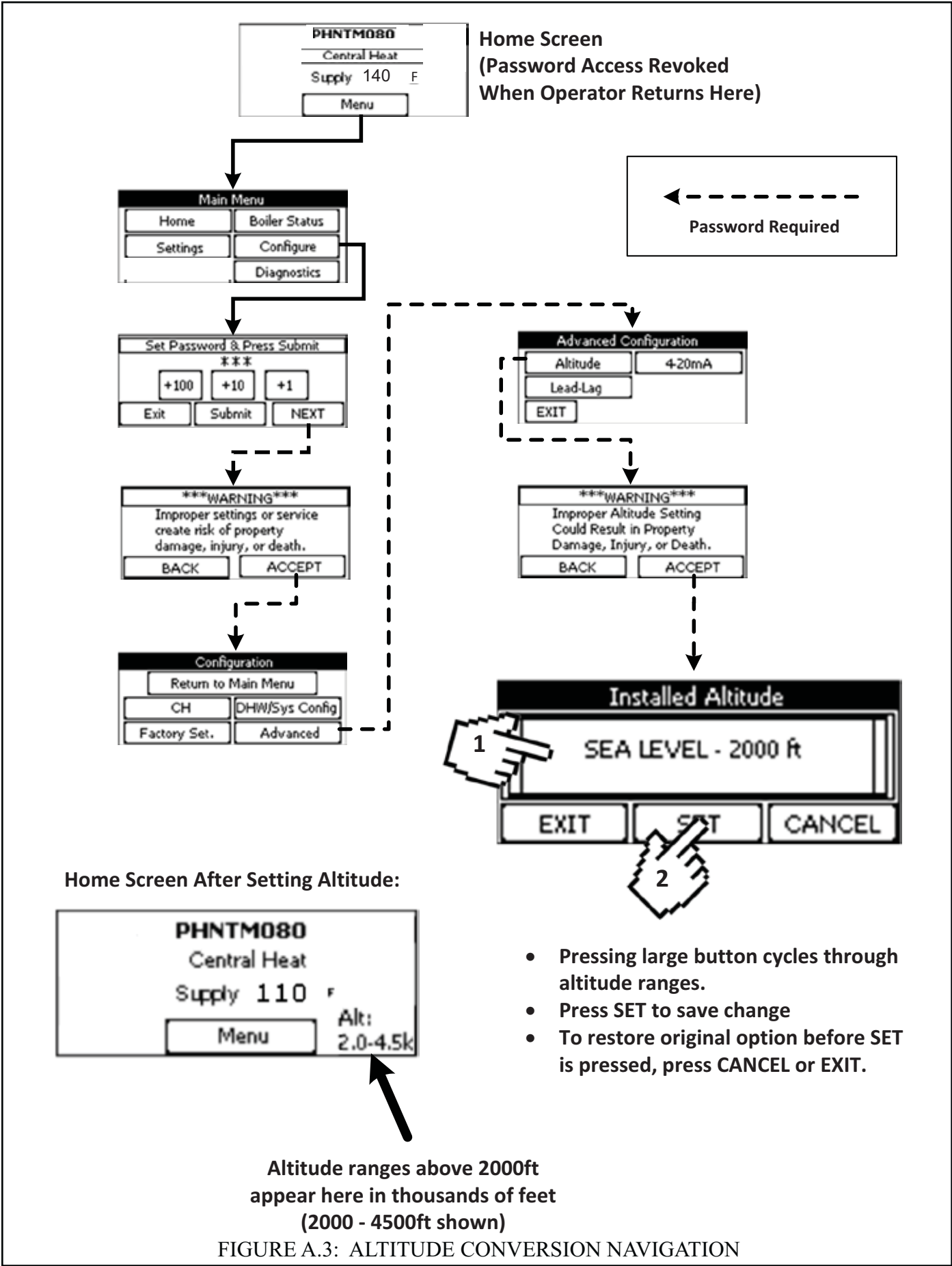

TABLE A.4: ACCEPTABLE COMBUSTION READINGS

Model	Fuel	Allowable CO2 Readings (%)				Max CO (PPM Air-Free)
		Sea Level - 2000 ft	2001 - 4500 ft	4501 - 7800 ft	7801 - 10200 ft	All Altitudes
80	Nat. Gas	8.7 - 9.3	8.7 - 9.2	8.7 - 9.1	8.7 - 9.1	200
	LP	10.1 - 10.3	NOT PERMITTED			200
100	Nat. Gas	8.5 - 9.3	8.5 - 9.3	8.5 - 9.3	8.5 - 9.3	200
	LP	10.1 - 10.3	10.0 - 10.3	9.9 - 10.2	9.8 - 10.1	200
120	Nat. Gas	8.8 - 9.3	8.8 - 9.3	8.8 - 9.3	8.8 - 9.3	200
	LP	10.1 - 10.3	9.9 - 10.2	9.9 - 10.2	9.5 - 9.8	200
150	Nat. Gas	8.6 - 9.3	8.6 - 9.3	8.6 - 9.3	8.6 - 9.3	200
	LP	9.7 - 10.3	9.8 - 10.3	9.8 - 10.3	9.8 - 10.1	200
180	Nat. Gas	8.5 - 9.1	8.5 - 9.1	8.5 - 9.1	8.5 - 9.1	200
	LP	9.9 - 10.3	9.9 - 10.3	9.9 - 10.2	NOT PERMITTED	200

TABLE A.5: ACCEPTABLE GAS INLET PRESSURE RANGE

Fuel	Inlet Pressure (in w.c.)	
	Sea Level - 2000ft	2001-10200ft
Nat. Gas	2.5 - 14.0	4.0 - 14.0
LP	11.0 - 14	11.0 - 14

## Appendix B: Special Requirements For Side-Wall Vented Appliances In The Commonwealth of Massachusetts

### IMPORTANT

The Commonwealth of Massachusetts requires compliance with regulation 248 CMR 4.00 and 5.00 for installation of side-wall vented gas appliances as follows:

(a) For all side wall horizontally vented gas fueled equipment installed in every dwelling, building or structure used in whole or in part for residential purposes, including those owned or operated by the Commonwealth and where the side wall exhaust vent termination is less than seven (7) feet above finished grade in the area of the venting, including but not limited to decks and porches, the following requirements shall be satisfied:

1. **INSTALLATION OF CARBON MONOXIDE DETECTORS.** At the time of installation of the side wall horizontal vented gas fueled equipment, the installing plumber or gasfitter shall observe that a hard wired carbon monoxide detector with an alarm and battery back-up is installed on the floor level where the gas equipment is to be installed. In addition, the installing plumber or gasfitter shall observe that a battery operated or hard wired carbon monoxide detector with an alarm is installed on each additional level of the dwelling, building or structure served by the side wall horizontal vented gas fueled equipment. It shall be the responsibility of the property owner to secure the services of qualified licensed professionals for the installation of hard wired carbon monoxide detectors.

- a. In the event that the side wall horizontally vented gas fueled equipment is installed in a crawl space or an attic, the hard wired carbon monoxide detector with alarm and battery back-up may be installed on the next adjacent floor level.
- b. In the event that the requirements of this subdivision can not be met at the time of completion of installation, the owner shall have a period of thirty (30) days to comply with the above requirements; provided, however, that during said thirty (30) day period, a battery operated carbon monoxide detector with an alarm shall be installed.

2. **APPROVED CARBON MONOXIDE DETECTORS.** Each carbon monoxide detector as required in accordance with the above provisions shall comply with NFPA 720 and be ANSI/UL 2034 listed and IAS certified.

3. **SIGNAGE.** A metal or plastic identification plate shall be permanently mounted to the exterior of the building at a minimum height of eight (8) feet above grade directly in line with the exhaust vent terminal for the horizontally vented gas fueled heating appliance or equipment. The sign shall read, in print size no less than one-half (1/2) inch in size, "GAS VENT DIRECTLY BELOW. KEEP CLEAR OF ALL OBSTRUCTIONS".

4. **INSPECTION.** The state or local gas inspector of the side wall horizontally vented gas fueled equipment shall not approve the installation unless, upon inspection, the inspector observes carbon monoxide detectors and signage installed in accordance with the provisions of 248 CMR 5.08(2)(a)1 through 4.

(b) **EXEMPTIONS:** The following equipment is exempt from 248 CMR 5.08(2)(a)1 through 4:

1. The equipment listed in Chapter 10 entitled "Equipment Not Required To Be Vented" in the most current edition of NFPA 54 as adopted by the Board; and
2. Product Approved side wall horizontally vented gas fueled equipment installed in a room or structure separate from the dwelling, building or structure used in whole or in part for residential purposes.

(c) **MANUFACTURER REQUIREMENTS - GAS EQUIPMENT VENTING SYSTEM PROVIDED.** When the manufacturer of Product Approved side wall horizontally vented gas equipment provides a venting system design or venting system components with the equipment, the instructions provided by the manufacturer for installation of the equipment and the venting system shall include:

1. Detailed instructions for the installation of the venting system design or the venting system components; and
2. A complete parts list for the venting system design or venting system.

(d) MANUFACTURER REQUIREMENTS - GAS EQUIPMENT VENTING SYSTEM NOT PROVIDED. When the manufacturer of a Product Approved side wall horizontally vented gas fueled equipment does not provide the parts for venting the flue gases, but identifies “special venting systems”, the following requirements shall be satisfied by the manufacturer:

1. The referenced “special venting system” instructions shall be included with the appliance or equipment installation instructions; and

2. The “special venting systems” shall be Product Approved by the Board, and the instructions for that system shall include a parts list and detailed installation instructions.

(e) A copy of all installation instructions for all Product Approved side wall horizontally vented gas fueled equipment, all venting instructions, all parts lists for venting instructions, and/or all venting design instructions shall remain with the appliance or equipment at the completion of the installation.



---

Manufacturer of Hydronic Heating Products  
P.O. Box 14818 3633 I. Street  
Philadelphia, PA 19134  
[www.crownboiler.com](http://www.crownboiler.com)

PN 980125  
Rev D, 12/14