

CROWN SERIES 24 Commercial Hot Water or Steam Boiler

Series 24 Specifications

BOILER MODEL	HORSE-POWER	GROSS OUTPUT (MBH)	NET I=B=R RATING			BURNER INPUT		HEATING SURFACE (SQ. FT.)		NET FIREBOX VOLUME (CU. FT.)	PRESSURE IN FIREBOX ("W.C.")	WATER CONTENT (GAL.)		BOILER WEIGHT W/WATER (LBS.)		VENT DIA. (IN.)
			SQ. FT.	MBH STEAM	MBH WATER	OIL (GPH)	GAS (MBH)	STEAM	WATER			STEAM	WATER	STEAM	WATER	
24-03	10.2	342	1071	257	297	3.05	438	34.2	37.0	3.2	.33	44.5	66.0	1439	1618	7
24-04	14.1	471	1471	353	410	4.10	594	48.6	54.3	4.8	.38	53.0	75.0	1811	1995	7
24-05	18.9	634	1983	476	551	5.50	792	63.0	71.5	6.4	.31	61.5	84.0	2184	2372	8
24-06	23.8	797	2492	598	693	6.90	990	77.5	88.8	7.9	.38	70.0	93.0	2557	2749	8
24-07	28.0	937	2929	703	815	8.10	1174	91.9	106.0	9.5	.36	78.5	102.0	2930	3126	8
24-08	32.5	1087	3396	815	945	9.40	1358	106.3	123.3	11.0	.35	87.0	111.0	3303	3503	10
24-09	39.3	1316	4146	995	1148	11.40	1641	120.7	140.5	12.6	.35	95.5	120.0	3676	3880	10
24-10	45.0	1505	4788	1149	1309	13.00	1867	135.1	157.8	14.2	.40	104.0	129.0	4048	4257	10
24-11	50.5	1690	5429	1303	1470	14.60	2093	149.5	175.0	15.7	.45	112.5	138.0	4421	4634	12
24-12	55.3	1852	5983	1436	1610	16.00	2320	164.0	192.3	17.3	.49	121.0	147.0	4794	5011	12

- Notes:**
- Trim suffix S = Steam Boiler W = Water Boiler
Fuel suffix N = Natural Gas O = Oil
 - I=B=R net ratings shown are based on piping and pick-up allowances which vary from 1.333 to 1.289 for steam and 1.15 for water. Consult manufacturer for installations having unusual piping and pick-up requirements, such as intermittent system operation, extensive piping systems, etc. The I=B=R burner capacity in GPH is based on oil having a heat value of 140,000 BTU per gallon.
 - Firebox volume does not include added volume of 8" extended burner mounting plate (BMP). If 8" BMP is specified (refer to Figure 1), add 0.7 cu. ft. to volume listed above.
 - Boiler ratings are based on 12.5% CO₂ (oil) and 9.7% CO₂ (natural gas), + .10" (inches) water column pressure at boiler flue outlet. Ratings shown above apply at altitudes up to 1000 feet on oil and 2,000 feet on gas. For altitudes above those indicated, the ratings should be reduced at the rate of 4% for each 1000 feet above sea level. Maximum Allowable Working Pressure: Steam Boiler – 15 PSI, Water Boiler – 80 PSI (US) - 45 PSI (Canada) Standard Safety (Relief) Valve Set Pressure: Steam Boiler – 15 PSI, Water Boiler – 30 PSI

Beckett Gas Burners (Natural Gas)

Boiler Model	Burner Model	Rate Control	STD. Motor Voltage	H.P.	Min. Inlet Pressure (in W.C.)	Gas Train Size
24-03	CG10.1S	On/Off	120/60/1	1/3	3.2	1"
24-04	CG10.4S	On/Off	120/60/1	1/3	3.6	1"
24-05	CG10.5S	On/Off	120/60/1	1/3	4.3	1-1/4"
24-06	CG10.6S	On/Off	120/60/1	1/3	4.4	1-1/2"
24-07	CG15.3S	Lo/Hi/Lo	120/60/1	1/2	4.0	1-1/2"
24-08	CG15.4S	Lo/Hi/Lo	120/60/1	1/2	4.4	1-1/2"
24-09	CG25.2S	Lo/Hi/Lo	120/60/1	3/4	4.3	1-1/2"
24-10	CG25.3S	Lo/Hi/Lo	120/60/1	3/4	4.9	1-1/2"
24-11	CG25.4S	Lo/Hi/Lo	120/60/1	3/4	4.9	1-1/2"
24-12	CG50.2S	Lo/Hi/Lo	208-240/60/1	2	3.9	1-1/2"

Minimum gas pressures shown are for standard burners only. See manual for minimum gas pressure when other size gas trains are used.

Beckett Oil Burners

Boiler Model	Burner Model	Rate Control	STD. Motor Voltage	H.P.
24-03	CF500	On/Off	120/60/1	1/3
24-04	CF800	On/Off	120/60/1	1/3
24-05	CF800	On/Off	120/60/1	1/3
24-06	CF1400	Lo/Hi/Lo	120/60/1	1/2
24-07	CF1400	Lo/Hi/Lo	120/60/1	1/2
24-08	CF1400	Lo/Hi/Lo	120/60/1	1/2
24-09	CF2300A	Lo/Hi/Lo	120/60/1	3/4
24-10	CF2300A	Lo/Hi/Lo	120/60/1	3/4
24-11	CF2500	Lo/Hi/Lo	240/60/1	2
24-12	CF2500	Lo/Hi/Lo	240/60/1	2



Specifications are subject to change without notice.

www.crownboiler.com | Philadelphia PA

S24 - 09/13
PN 980521 - R1



COMMERCIAL, FORCED DRAFT, HOT WATER OR STEAM BOILER

SIZES FROM 342 TO 1,842 MBH OUTPUT

Series 24 Features

- Cast iron sectional heat exchanger and push nipples
- Vertical flue design
- Easily assembled with short individual draw rods
- Optional tankless heater for domestic hot water
- Top or rear vent connections
- Side cleanout plates
- Optional Return Temperature Control (RTC)
- Ten sizes ranging from 342 to 1,852 MBH output

The right fit for any commercial job

- The Series 24 is built to handle any installation - businesses, institutions, apartments, and other commercial buildings
- Available for use with gas, oil, or combination gas/oil fired in hot water and steam models
- Delivered in easily handled sections for convenience on the job site



See back side for specifications

www.crownboiler.com | Philadelphia PA

CROWN SERIES 24 Commercial Hot Water or Steam Boiler

Ten reasons why you need the Series 24 commercial boiler

- Optimum for large installations** – Available in ten sizes from 342,000 to 1,852,000 BTU/hr output. down stairs making this boiler ideal for installs where the boiler room is not readily accessible.
- Gas, oil or combination gas/oil fired** – Customer's preference in the choice of fuels for economy and availability may be an important part of the purchase decision.
- Hot water or steam** – The Series 24 has been designed to meet a wide variety of installations.
- Tankless heater available for domestic hot water** – Convenient for small spaces or difficult installations that preclude a separate water heater. Finned copper coil heats water fast, and piping is easier to install.
- Cast iron construction** – Cast iron heat exchanger sections and push nipples provide long life. Cast iron resists the effect of petroleum-based chemicals such as corrosion inhibitors, pump lubricants and antifreeze. Cast iron push nipples are important because they expand and contract at the same rate as the sections they join, which provides integrity to the entire assembly.
- Convenient delivery in sections** – Delivery is available in easily handled sections that can be maneuvered through doorways and
- Easy assembly** – Once in place, the sections are easily assembled using a 3/4-inch drive ratchet with a 1-1/16-inch-deep socket and a wrench. Short draw rods pass through the sections' reinforced lugs, resulting in fast, strain-free assembly.
- Versatile venting options** – The Series 24 is a forced draft boiler that eliminates the need for high chimneys or draft inducers. Uniquely, the boiler can be vented from either the top or rear for maximum installation flexibility. Rear outlet venting requires only 6-1/2 feet of vertical clearance from floor to ceiling.
- Hassle-free maintenance** – All regular maintenance access areas are located on the left side, allowing the Series 24 to be installed 9 inches from the right sidewall. Removable jacket panels and flue cover plates simplify access to the heating surfaces.
- It's a CROWN!** Satisfied customers are our goal. So, all CROWN boilers employ the latest technology for performance and safety. We offer a wide range of products to meet each customer's individual needs, and we offer competitive pricing, attractive warranties and optional extended coverage.

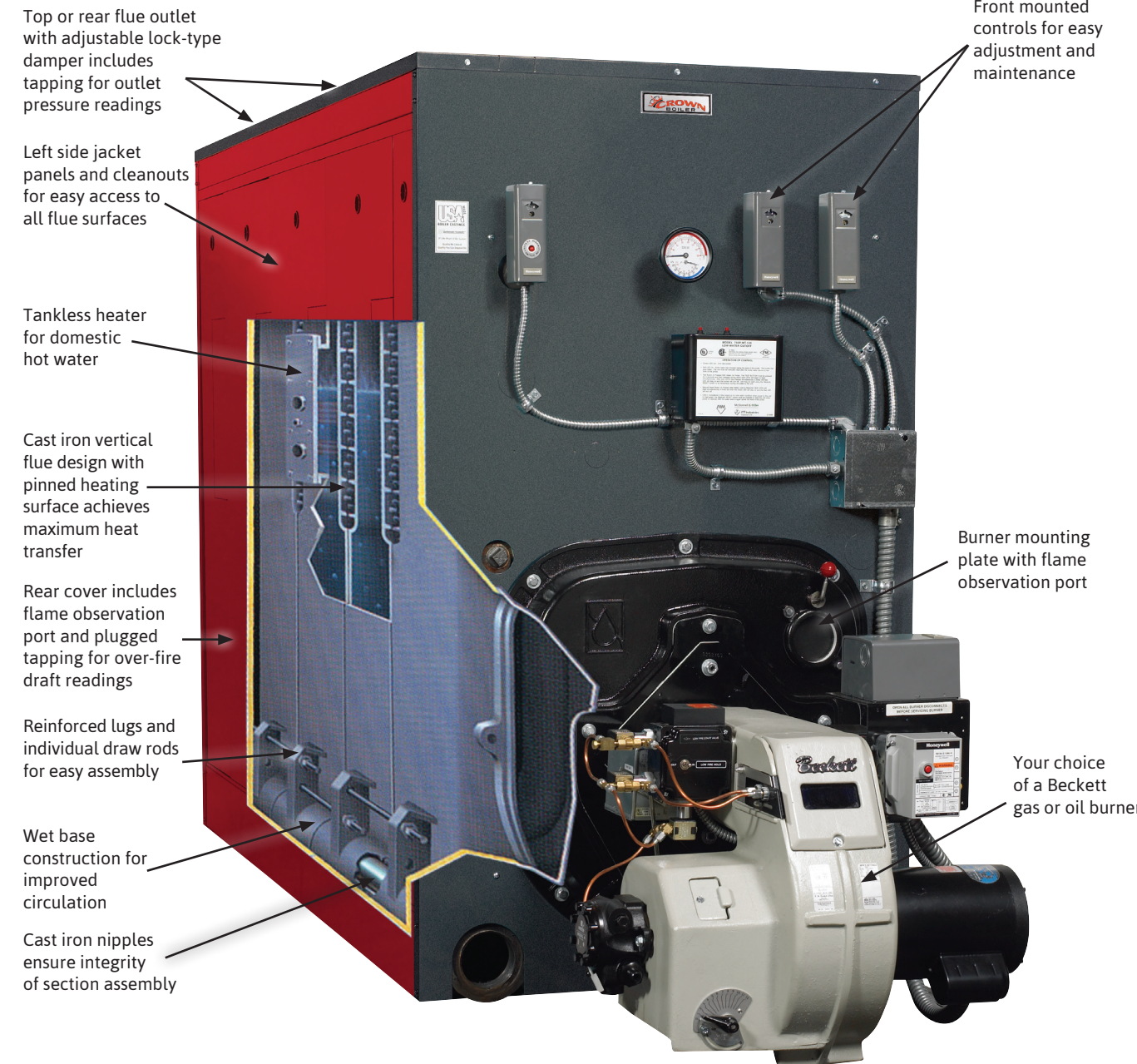

Standard Equipment

All Boilers – Sections unassembled, flush insulated jacket, burner mounting plate, burner adapter plate, rear flue damper (top outlet optional), flue canopy, rear observation port cover, target wall (S24-03), and miscellaneous plugs, bushings and fittings.

Steam Trim – 15 PSI safety valve, L404A pressuretrol, gauge glass assembly, steam gauge.

Water Trim – 30 PSI safety relief valve, L4006A high limit, pressure temperature gauge.

Oil Boilers – Flange mounted flame retention oil burner furnished with 2 stage fuel unit, primary control and dual oil valves.

Gas Boilers – Flange mounted gas burner with standard controls meeting the latest UL requirements, dual gas valves and electronic ignition.

Optional Equipment

Top outlet flue damper, tankless heaters, 50 PSI relief valves (water), and combustion and hydronic controls to meet ASME CSD-1.

Front mounted controls for easy adjustment and maintenance

Top or rear flue outlet with adjustable lock-type damper includes tapping for outlet pressure readings

Left side jacket panels and cleanouts for easy access to all flue surfaces

Tankless heater for domestic hot water

Cast iron vertical flue design with pinned heating surface achieves maximum heat transfer

Rear cover includes flame observation port and plugged tapping for over-fire draft readings

Reinforced lugs and individual draw rods for easy assembly

Wet base construction for improved circulation

Cast iron nipples ensure integrity of section assembly

Burner mounting plate with flame observation port

Your choice of a Beckett gas or oil burner



Series 24 Dimensions (in inches)

BOILER MODEL	NUMBER OF SECTIONS	'A'	'B'	NUMBER OF STEAM RISERS	'C'	'D'	MAXIMUM NUMBER OF HEATERS 'E'	FLUTE OUTLET DIAMETER 'F'	BURNER MOUNTING PLATE WIDTH 'G'	BECKETT ¹		APPROX. K.D. B.L. SHIPPING WEIGHT LB.
										CF OIL 'H'	CG GAS 'I'	
24-03	3	18-1/4	12	1	—	9-1/8	1	7	8	9-3/4	20-7/8	1363
24-04	4	24-1/4	18	1	—	12-1/8	1	7	8	11-3/4	21-5/8	1675
24-05	5	30-1/4	24	1	—	15-1/8	1	8	8	11-3/4	21-5/8	1987
24-06	6	36-1/4	30	1	—	18-1/8	2	8	4	20-5/8	21-5/8	2273
24-07	7	42-1/4	36	2	—	21-1/8	2	8	4	20-5/8	28-5/8	2589
24-08	8	48-1/4	42	2	—	24-1/8	2	10	4	20-5/8	28-5/8	2901
24-09	9	54-1/4	48	2	—	27-1/8	3	10	4	21-1/8	29-1/8	3282
24-10	10	60-1/4	54	2	—	30-1/8	3	10	4	21-1/8	29-1/8	3614
24-11	11	66-1/4	60	2	—	33-1/8	3	12	4	22-5/8	29-1/8	3925
24-12	12	72-1/4	66	3	30	36-1/8	4	12	4	22-5/8	29-1/2	4252

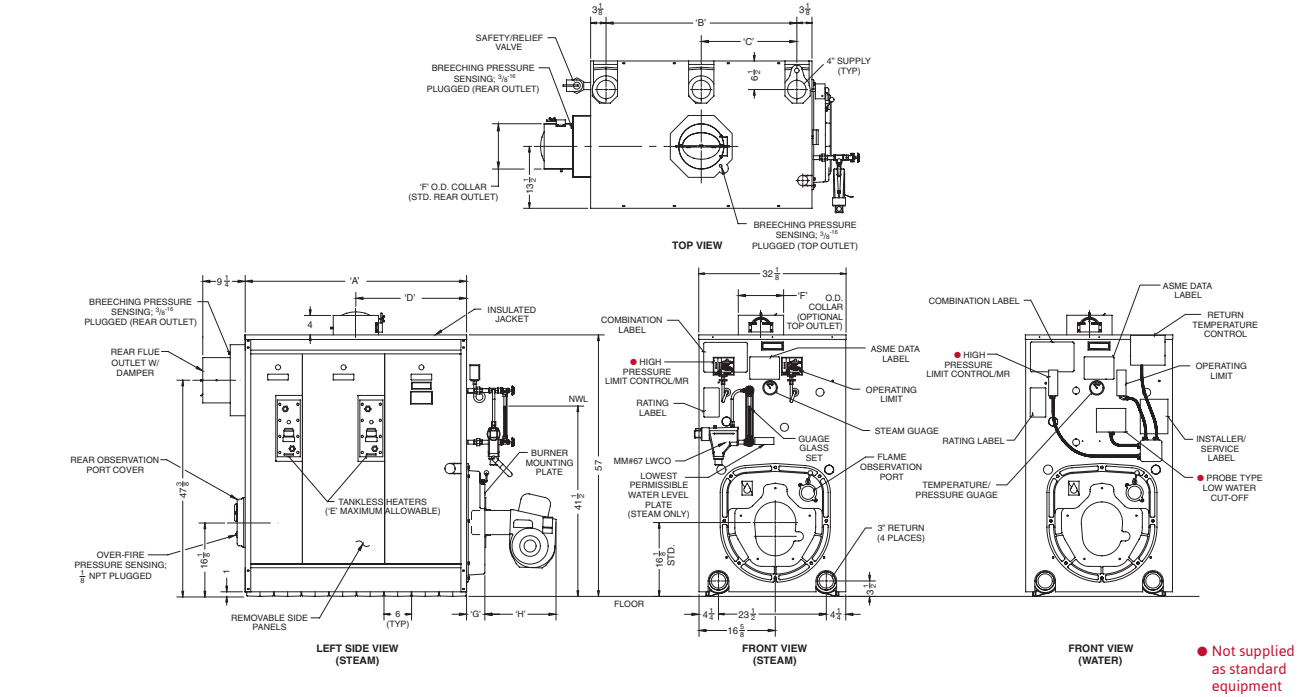

Tankless Heater Ratings in GPM

BOILER MODEL	NUMBER OF 24 TANKLESS HEATERS INSTALLED			
	1	2	3	4
24-03	6.75	—	—	—
24-04	7.5	—	—	—
24-05	7.5	—	—	—
24-06	7.5	15	—	—
24-07	7.5	15	—	—
24-08	7.5	15	—	—
24-09	7.5	15	22.5	—
24-10	7.5	15	22.5	—
24-11	7.5	15	22.5	—
24-12	7.5	15	22.5	30

Continuous draw heated from 40°F to 140°F with 200°F boiler water.

Multi-Heater Manifold

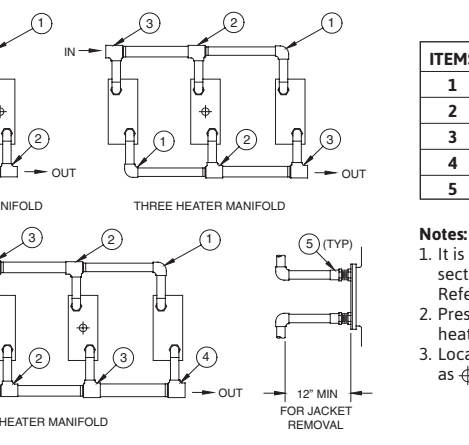

ITEMS	DESCRIPTION
1	1-1/4" Copper Elbow
2	1-1/2" x 1-1/4" x 1-1/4" Copper Tee
3	2" x 1-1/2" x 1-1/4" Copper Tee
4	2" x 2" x 1-1/4" Copper Tee
5	1-1/4" Copper x MIP Adapter

- Notes:**
- It is important that tankless heater sections be correctly located in the boiler. Refer to installation manual.
 - Pressure drop across each T-4 tankless heater = 5.25 PSI at 7.5 GPM flow rate.
 - Locate heater control in heater identified as

SERIES 24 Commercial Hot Water or Steam Boiler

Burner Mounting Plates and Adapter Plates

BECKETT ("CF" SERIES) BURNER ADAPTER PLATE

BOILER MODEL	PART NO.	I.D. NO.	'A' DIA.	'B' DIA.	'C' REF.
24-03 THRU 24-05	330400	920	4-3/4	10	7-1/16
24-06 THRU 24-08	330401	921	6-1/8	10	7-1/16
24-09 THRU 24-12	330402	922	6-3/4	10	7-1/16

BECKETT ("CG" SERIES) BURNER ADAPTER PLATE

BOILER MODEL	PART NO.	I.D. NO.	'A' DIA.	'B' DIA.	'C' REF.
24-03 THRU 24-06	330400	920	4-3/4	10	7-1/16
24-07 THRU 24-08	330401	921	6-1/8	10	7-1/16
24-09 THRU 24-11	330403	923	7-1/4	10	7-1/16
24-12	330404	924	8-1/8	10	7-1/16

- Note:**
- A burner adapter plate is needed for each boiler.

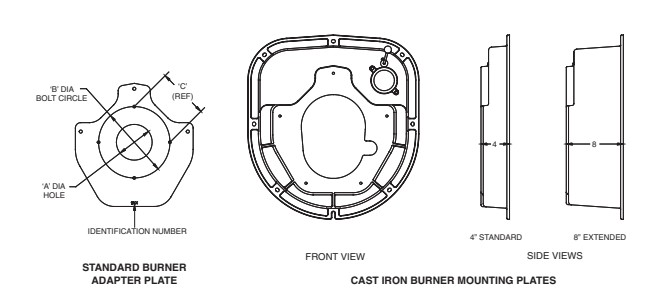

Series 24 Minimum Piping Recommendations – Water Boiler

Impact of System Piping – Many hot water systems are zoned. Some also use mixing valves to control the water temperature in the system. These features can cause the flow through the boiler to vary dramatically, depending on the status of the zones or mixing valves. In addition, the large water content of many commercial systems has the potential to subject the boiler to operation with low return temperatures for an extended period of time. These factors can shorten the life of a boiler due to thermal shock or flue gas condensation.

Crown's 3 Recommendations – On the following pages, CROWN provides three basic recommendations for near-boiler piping that are intended to maximize the life expectancy of the boiler by protecting it from flue gas condensation and thermal shock. Each protects the boiler by making sure that both of the following conditions are met:

- The flow *through the boiler* is high enough to ensure a temperature rise of less than 40°F

Control Tappings

TAPPING LOCATION	SIZE (IN.)	STEAM BOILER	WATER BOILER
A	4	Supply	Supply
B	4	Plug (24-03 thru 24-06) Supply (24-07 thru 24-12)	Plug
C	3	Blow-Off Valve	Return
D	3	Return	Plug (24-03 thru 24-11) Return (24-12)
E	3	Plug	Blow-Off / Drain Valve
F	3	Plug	Plug
G	1-1/2	Safety Valve / Surface Skim Tap	Relief Valve
J1	1	Plug	Plug
J2	1	Float L.W.C.O.	Plug
K	3/4	Plug	Probe L.W.C.O.
M	3/4	Operating Pressure Limit Control	Operating Temperature Limit Control
N	3/4	Hi Pressure Limit Control / Manual Reset	Hi Temperature Limit Control/Manual Reset
P	1/2	Gauge Glass/#67 L.W.C.O.	Plug
Q	1/2	Steam Gauge (Bush to 1/4")	Temperature/Pressure Gauge (Bush to 1/4")
S	3/4	Tankless Heater Control	Tankless Heater Control
T	3/4	Firing Rate Pressure Control	Firing Rate Temperature Control

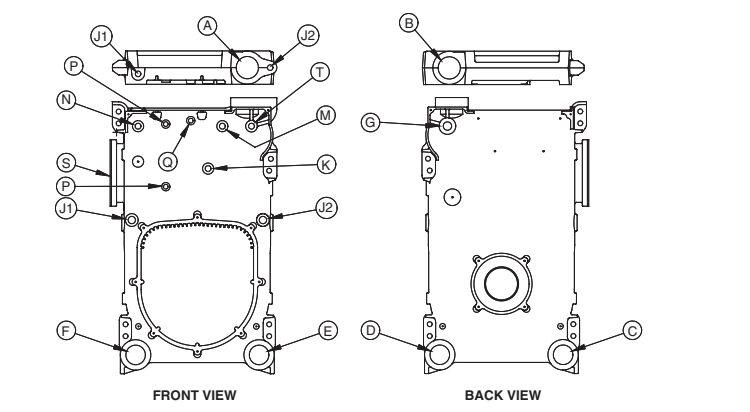

- The return temperature does not fall below 135°F for an extended period of time.

RTC Return Temperature Control – Piping

Recommendation 3 makes use of CROWN's optional RTC (Return Temperature Control). This control provides an economical and effective way of protecting the boiler from thermal shock and condensation. It can be incorporated into most hot water systems with minimal modifications to the system design and operation. When this option is used on multiple Series 24s, one RTC is required for each boiler. The CROWN RTC is also available with an outdoor reset option. This provides additional energy savings by modulating system water temperature to match the building load requirements.

Series 24 Minimum Piping Recommendations – Water Boiler

Recommendation 1 is used when the load is constant and not varied due to mixing or multiple zones. Use when:

- system return water *is not less* than 135° F for prolonged periods of time
- system flow *does not impact* flow through the boiler

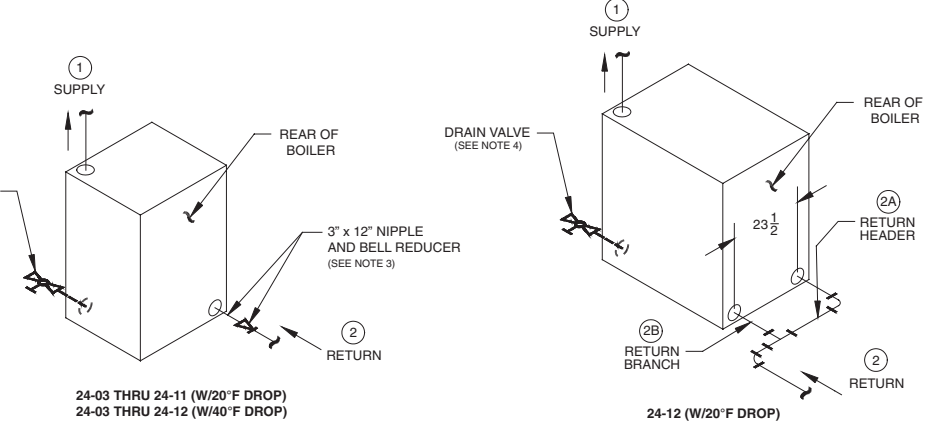

Recommendation 2 is a primary-secondary piping method that maintains a constant flow through the boiler by using a secondary boiler circulator. This arrangement isolates the boiler from flow variations but does not safe-guard against cold return water temperatures. Use when:

- system return water *is not less* than 135° F for prolonged periods of time
- system flow *does not impact* flow through the boiler (i.e. zoning, mixing)

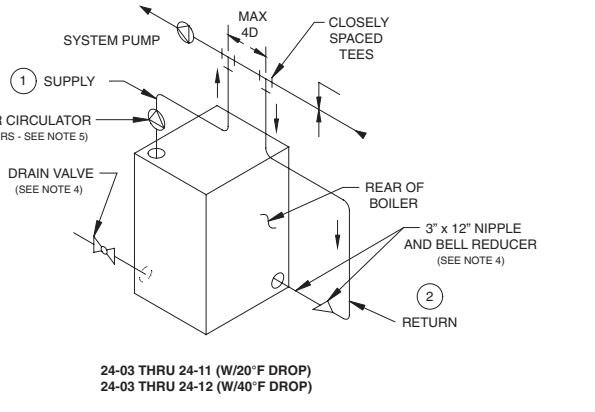

PIPE SIZING AND NOTES FOR RECOMMENDATIONS 1 AND 2

BOILER MODEL	SUPPLY PIPING SIZE (IN) (1)		RETURN PIPING SIZE (IN)		
	20°F DROP	40°F DROP	RETURN (2)	RETURN HEADER (2A)	RETURN BRANCH (QTY.) SIZE (2B)
24-03	2	1-1/2	2	1-1/2	—
24-04	2	1-1/2	2	1-1/2	—
24-05	2	1-1/2	2	1-1/2	—
24-06	2-1/2	1-1/2	2-1/2	1-1/2	—
24-07	2-1/2	2	2-1/2	2	—
24-08	2-1/2	2	2-1/2	2	—
24-09	3	2	3	2	—
24-10	3	2-1/2	3	2-1/2	—
24-11	3	2-1/2	3	2-1/2	—
24-12	4	2-1/2	4	2-1/2	3 (2) 3

- Notes:**
- All piping is schedule 40.
 - Pipe sizes listed are based on a 20° F or 40° F differential (temperature drop). Select one to match application.
 - When specified return piping is less than 3", install 3" x 12" nipple and appropriate size bell reducer directly into boiler return tapping as shown.
 - Drain valve—ball valve preferable, gate valve acceptable alternative (supplied by others)—Minimum valve size per ASME code is 3/4" NPT.

Recommendation 3 is used when the return water temperature goes below 135°F for prolonged periods of time. This is also primary-secondary piping, but includes the addition of a 3-way valve, return water sensor and boiler-mounted RTC Return Temperature Control.

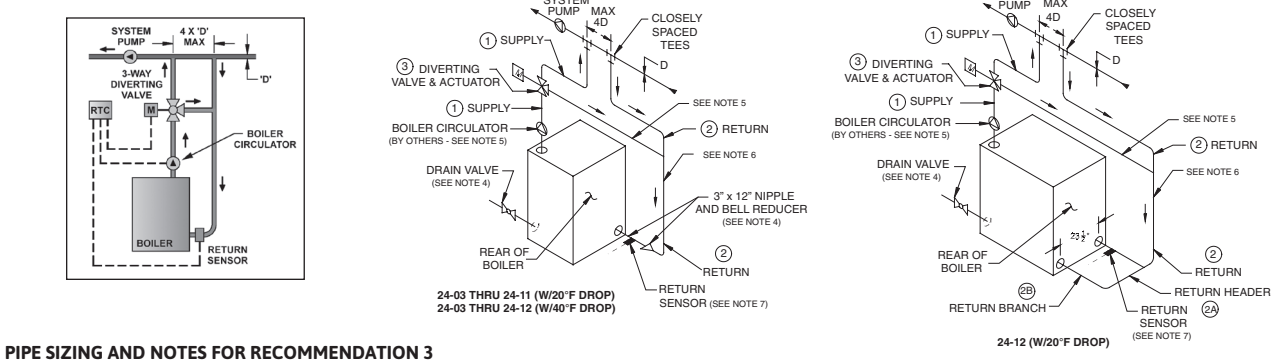

PIPE SIZING AND NOTES FOR RECOMMENDATION 3

BOILER MODEL	SUPPLY PIPING SIZE (IN) (1)		RETURN PIPING SIZE (IN)			
	20°F DROP	40°F DROP	20°F DROP	40°F DROP	RETURN HEADER (2A)	RETURN BRANCH (QTY.) SIZE (2B)
24-03	2	1-1/2	2	1-1/2	—	—
24-04	2	1-1/2	2	1-1/2	—	—
24-05	2	1-1/2	2	1-1/2	—	—
24-06	2-1/2	1-1/2	2-1/2	1-1/2	—	—
24-07	2-1/2	2	2-1/2	2	—	—
24-08	2-1/2	2	2-1/2	2	—	—
24-09	3	2	3	2	—	—
24-10	3	2-1/2	3	2-1/2	—	—
24-11	3	2-1/2	3	2-1/2	—	—
24-12	4	2-1/2	4	2-1/2	3	(2) 3

- Notes:**
- All piping is schedule 40.
 - Pipe sizes listed are based on a 20° F or 40° F differential (temperature drop). Select one to match application.
 - When specified return piping is less than 3", install 3" x 12" nipple and appropriate size bell reducer directly into boiler return tapping as shown.
 - Drain valve—ball valve preferable, gate valve acceptable alternative (supplied by others)—Minimum valve size per ASME code is 3/4" NPT.
 - Maximum linear feet of pipe from 3-way bypass port to sensor location = 11 feet. Bypass line shall be the same diameter as return A.
 - Minimum linear feet of pipe from point of mixing (where bypass meets return line) to sensor location = 4 feet.
 - Install special 3" x 12" nipple with 1/4" NPT side tapping closest to boiler. Where applicable, use bell reducer to adapt to recommended return pipe size.
 - Proper boiler circulator sizing is listed in RTC literature.

Series 24 Minimum Piping Recommendations – Steam Boiler

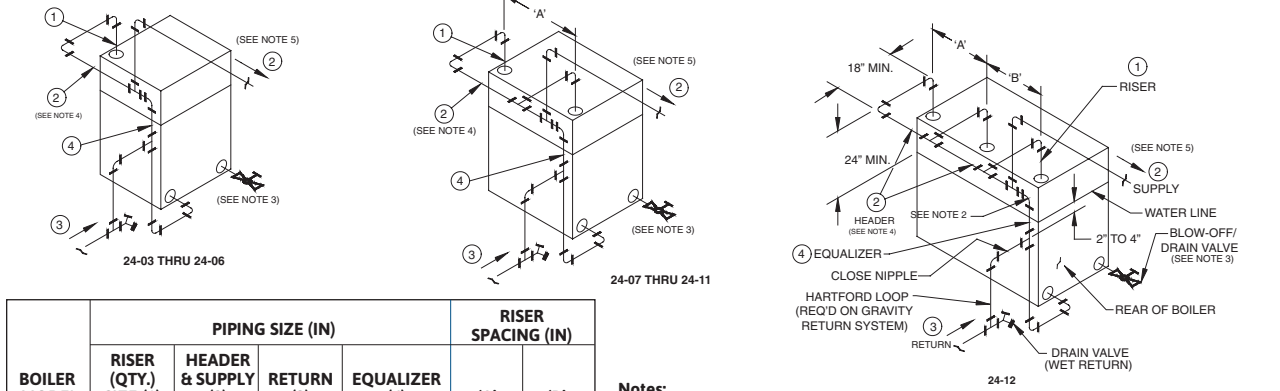

BOILER MODEL	RISER (QTY.) SIZE (1)	PIPING SIZE (IN)			RISER SPACING (IN)	
		HEADER & SUPPLY (2)	RETURN (3)	EQUALIZER (4)	'A'	'B'
24-03	(1) 3"	3"	1-1/2"	2"	—	—
24-04	(1) 4"	4"	2"	2"	—	—
24-05	(1) 4"	4"	2"	2"	—	—
24-06	(1) 4"	4"	2-1/2"	2-1/2"	—	—
24-07	(2) 4"	6"	2-1/2"	2-1/2"	36"	—
24-08	(2) 4"	6"	2-1/2"	2-1/2"	42"	—
24-09	(2) 4"	6"	2-1/2"	2-1/2"	48"	—
24-10	(2) 4"	6"	3"	3"	54"	—
24-11	(2) 4"	6"	3"	3"	60"	—
24-12	(3) 4"	6"	3"	3"	30"	36"

- Notes:**
- All piping is schedule 40.
 - To prevent condensate from being trapped in header, do not reduce equalizer elbow at header connection.
 - Drain/blowoff valve—ball valve preferable, gate valve acceptable alternative (supplied by others).
 - Minimum valve size per ASME code is 3/4" NPT 24-03/24-05; 1" NPT 24-06/24-10; 1-1/4" NPT 24-11/24-12.
 - Increasing the valve size will improve the blowdown operation
 - In all cases, piping connection blowoff valve to boiler should be full size to the point of discharge.
 - For pumped return systems, see Series 24 installation manual.