



Two Models FCX 22 and FCX 30
Unique Features and Benefits
Operates Efficiently on #1 or #2 Fuel Oil
Great for Use in Arctic Conditions
Designed and Manufactured by
Geminox for Residential Use



FCX 22
FCX 30

FCX Boiler 92-97% AFUE Rating

Thousands of installations worldwide have proven the FCX boiler to be most reliable and efficient. The FCX features a steel, primary non-condensing heat exchanger coupled to a condensing, stainless secondary heat exchanger. A built-in three-way mixing valve permits all-season comfort at maximum efficiency. The FCX has dual-temperature circuit capability, which makes combining low and high-temperature applications in the same structure quick and easy. It is ideal for year-round DHW service and is so silent, clean and nicely finished that it can be installed almost anywhere within most buildings. The FCX is approved as a sealed-combustion device taking its combustion air from outside via a concentric vent or it can use room air for combustion.

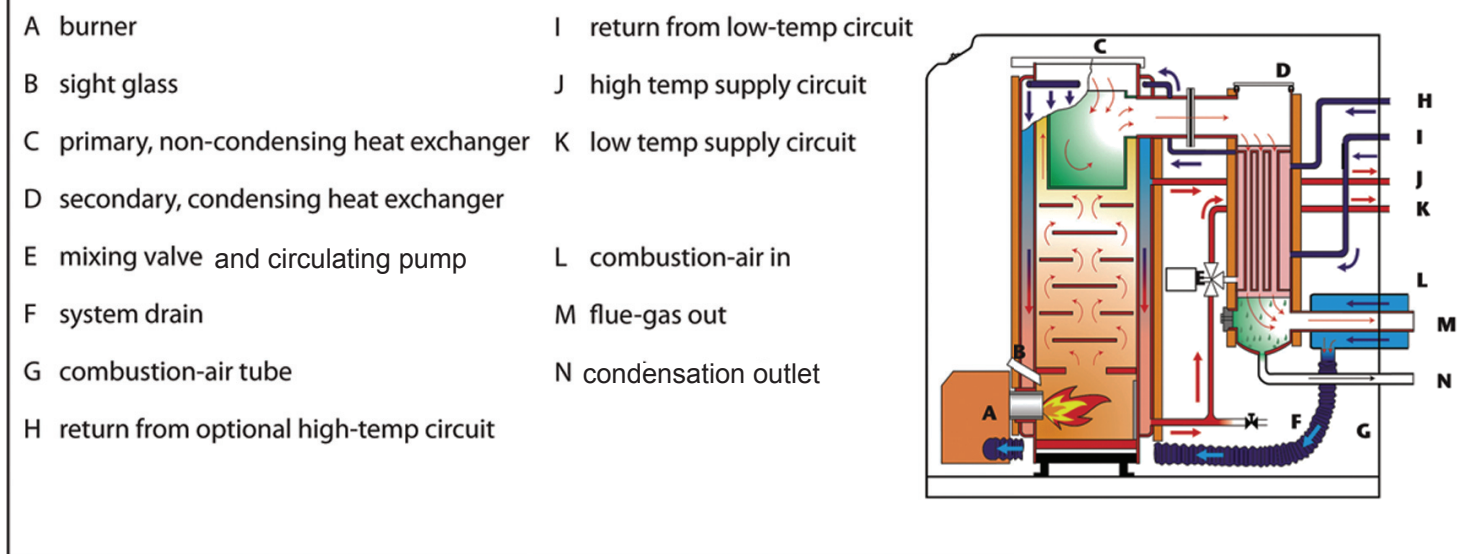

Inside View of the FCX Boiler

1. Built in temperature controls provide heating comfort.
2. Economical PP/PVC Vent System: sealed system brings in fresh air for combustion and allows flue gas to be vented safely outdoors either vertically or horizontally. Single wall PP options available.
3. All burners equipped with fuel line heater to provide maximum efficiency.



4. Expansion tank, mixing valve and circulation pump, built-in for ease of installation.
5. Stainless steel secondary heat exchanger to transfer any unused energy from the primary heat exchanger thus minimizing your fuel bills
6. Steel primary heat exchanger for long life durability



An Energy Star Qualified Boiler! Energy Star lists the FCX oil-fired fully condensing boiler an Annual Fuel Utilization Efficiency (AFUE) rating of 92-97%.

Proud Member



COLD CLIMATE HOUSING RESEARCH CENTER
CCHRC

SPECIFICATIONS		FCX 22	FCX 30
Rated Output		76,000 Btu/h	104,000 Btu/h
Rated Input		81,250 Btu/h	107,500 Btu/h
Combustion Chamber Length		8.98"	9.41"
Combustion Chamber Diameter		11.57"	13.78"
Combustion Chamber Volume		915 Cubic Inches	1,403 Cubic Inches
Combustion Prod. Circuit Volume		3,051 Cubic Inches	3,204 Cubic Inches
Flue Pressure Drop		H20 0.10"	H20 0.10"
Max. Heating Service Pressure		43.5 PSI	43.5 PSI
Max. Heating Circuit Water Temperature		158°F	158°F
Water Overheating Safety Thermostat Setting		230°F	230°F
Combustion Prod. Overheating Safety Thermostat Setting		230°F	230°F
Heating Circuit Water Capacity		4.23 Gallons	6.6 Gallons
Primary Water Flow Rate (122/158°F)		254 Gal/h	343 Gal/h
Water Pressure Drop (at nominal flow rate)		1.0 MCE	1.8 MCE
Power Absorbed (with burner, without circulator)		0.2 kW	0.2 kW
Power Consumption		235 W	235 W
Full Load Current		2.0 Amps FLA	2.0 Amps FLA
Max. Fuse/Circuit Breaker Size		15 Amps	15 Amps
Dimensions	Height	39.1"	39.1"
	Width	23.7"	23.7"
	Depth	27.5"	27.5"
Packaged Weight		322 lbs.	369 lbs.
Pipe Connections	Water Heating Supply/Return	3/4"	3/4"
	Domestic Hot Water or Second Heating Circuit	3/4"	3/4"
	Condensate Drain	1-1/2"	1-1/2"
	Heating Water Drain	1/2"	1/2"
	Air Bleed	3/4"	3/4"
	Safety Pressure Relief Valve	3/4"	3/4"



Dimensions

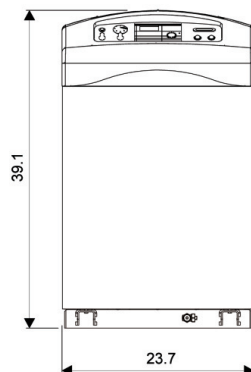

Front view

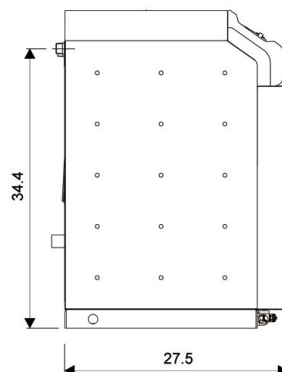

Side view

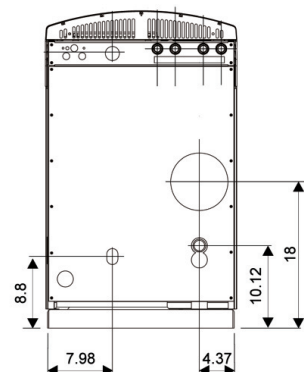

Rear view

BS Indirect Domestic Hot-Water Storage Tanks

The BS series of domestic hot-water storage tanks are among the world's finest products of this type. Their high-quality, all stainless waterside construction and oversized heat exchanger combine to deliver lifetime performance at the very highest efficiency levels. The pleasing design, exceptional fit and finish make the BS Series a world-class indirect tank.

Technical Specifications

Models		BS25	BS40	BS50	BS80
Nominal Storage	GAL.	25	40	50	80
Height	IN.	27.5	36.4	45.3	63
Diameter	IN.	23.6	23.6	23.6	23.6
All Pipe Connections	MPT	3/4"	3/4"	3/4"	3/4"
Max. DHW Pressure	PSI	100	100	100	100
Aquastat Range	°F	68-176	68-176	68-176	68-176
Aquastat Differential	°F	10.8	10.8	10.8	10.8
Inspection Port Opening	IN.	3.9	3.9	3.9	3.9
Nominal Exchanger Power at 170°F. Av. Boiler Water Temperature	MBH	115	115	200	210
Nominal Preheat Time from 50°F to 140°F stored	MIN.	10	15	12	17
Continuous Output at 110°F	GPM	3.8	3.8	6.5	6.7
Nominal First Hour Draw at 70°F Rise	GAL.	250	260	430	465
Dry Weights	LBS.	71	86	121	159

Since the tank does not actually heat the water (the boiler does), the actual efficiency will be dependent upon the efficiency of the boiler. When the boiler used is the FCX, the efficiency should be 93% plus.



Your Authorized FCX Dealer

An Aesthetic Functional Design

The appliance must be installed and maintained by a certified professional, according to current statutory and industry standards. Installation must be done in conformance with all applicable regulations and codes (example, building, fire etc.) for the local area in which it is installed. Where specific recommendations are made in text or by diagram in this document, the applicable regulations and codes have precedence and govern.

To avoid personal injury or property damage, the product described by this brochure must be installed, operated and maintained in strict compliance with the instructions. In the interest of constant product development and improving our products, we may change the specifications without prior notice.